

## 300mA Low Dropout Voltage Regulator

### FEATURES

- 1% Output Accuracy 3.3V, 5V, at 300mA Output
- Very Low Quiescent Current
- 0.3V (Typ.) Dropout Voltage at 300mA
- Extremely Tight Load and Line Regulation
- Current & Thermal Limiting
- Reverse Battery Protection
- Equivalent Replacement For LT1521
- Available in RoHS Compliant, Lead Free Packages: TO-252, SOT-223, TO-220 & TO-263

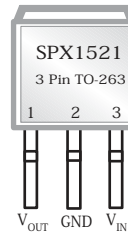

### DESCRIPTION

The SPX1521 is a low power voltage regulator. This device is an excellent choice for use in battery-powered applications such as cordless telephones, radio control systems, and portable computers. The SPX1521 features very low quiescent current and very low dropout voltage. This includes a tight initial tolerance of  $\pm 1\%$  max, and very low output temperature coefficient, making the SPX1521 useful as a low-power voltage reference.

The SPX1521 is offered in 3 pin TO-252, SOT-223, TO-220 & TO-263 packages.

### TYPICAL APPLICATIONS CIRCUIT

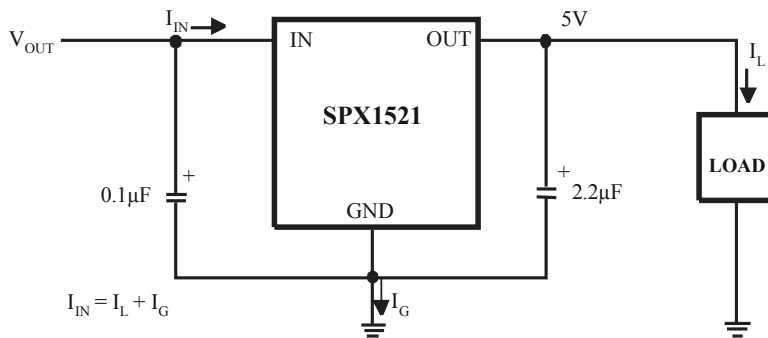

## ABSOLUTE MAXIMUM RATINGS

Power Dissipation ..... Internally Limited  
 Lead Temp. (Soldering, 5 Seconds)..... 260°C  
 Storage Temperature Range..... -65°C to +150°C  
 Operating Junction Temperature Range ..... -40°C to +125°C  
 Input Supply Voltage..... -20V to +20V

Shutdown Input Voltage.....-0.6V to +6.5V  
 ESD Rating.....2kV Min

## ELECTRICAL CHARACTERISTICS

Electrical characteristics at  $V_{IN} = 6V$ ,  $I_O = 1mA$ ,  $C_{OUT} = 2.2\mu F$ ,  $T_A = 25^\circ C$ , unless otherwise specified.

**Boldface** applies over the full operating temperature range.

PARAMETER	CONDITIONS (Note 2)	TYP	MIN	MAX	UNITS
<b>3.3V Version</b>					
Output Voltage	$1mA \leq I_L \leq 300mA$	3.3	3.267	3.333	V
		<b>3.3</b>	<b>3.217</b>	<b>3.382</b>	
Reverse Output Current	$V_{OUT} = 3.3V, V_{IN} = 0V$	16		25	$\mu A$
<b>5.0V Version</b>					
Output Voltage	$1mA \leq I_L \leq 300mA$	5.0	4.950	5.050	V
		<b>5.0</b>	<b>4.880</b>	<b>5.120</b>	
Reverse Output Current	$V_{OUT} = 5.0V, V_{IN} = 0V$	16		25	$\mu A$
<b>All Voltage Options</b>					
Output Voltage Temperature Coefficient	(Note 1)	20		<b>100</b>	ppm/°C
Line Regulation	$6V \leq V_{IN} \leq 20V$ (Note 4)	1.5		<b>20</b>	mV
Load Regulation (Note 3)	$I_L = 1$ to 300mA	4		20 <b>30</b>	mV
Dropout Voltage (Note 5)	$I_L = 1mA$	0.13		0.17 <b>0.25</b>	V
	$I_L = 300mA$	0.30		0.55 <b>0.70</b>	
Ground Current	$I_L = 1mA$	<b>100</b>		<b>150</b>	$\mu A$
	$I_L = 10mA$	<b>350</b>		<b>500</b>	
	$I_L = 50mA$	<b>1.5</b>		<b>3</b>	mA
	$I_L = 100mA$ $I_L = 300mA$	<b>2</b> <b>5</b>		<b>6</b> <b>14</b>	
Current Limit	$V_{OUT} = 0$	330		<b>500</b>	mA
Ripple Rejection	$V_{IN} - V_{OUT} = 1V$ (Avg), $V_{RIPPLE} = 0.5Vp-p$ , $F_{RIPPLE} = 120Hz, I_{LOAD} = 150mA$	58	50		dB
Input Reverse Leakage Current	$V_{IN} = -20V, V_{OUT} = 0V$			<b>1.0</b>	mA

**Note 1:** Output or reference voltage temperature coefficients defined as the worst case voltage change divided by the total temperature range.

**Note 2:** Unless otherwise specified all limits are guaranteed for  $T_j = 25^\circ C$ ,  $V_{IN} = 6V$ ,  $I_L = 1mA$  and  $C_L = 2.2\mu F$ .

**Note 3:** Regulation is measured at constant junction temperature, using pulse testing with a low duty cycle. Changes in output voltage due to heating effects are covered under the specification for thermal regulation.

**Note 4:** Line regulation for the SPX1521 is tested at  $25^\circ C$  for  $I_L = 1mA$ . For  $T_j = 125^\circ C$ , line regulation is guaranteed by design.

**Note 5:** Dropout voltage is defined as the input to output differential at which the output voltage drops 100 mV below its nominal value measured at 1V differential.

**External Capacitors**

The stability of the SPX1521 requires a 2.2μF or greater capacitor between output and ground. Oscillation could occur without this capacitor. Most types of tantalum or aluminum electrolytic works fine here. For operations of below -25°C solid tantalum is recommended since the many aluminum types have electrolytes that freeze at about -30°C. The ESR of about 5Ω or less and resonant frequency above 500kHz are the most important parameters in the value of the capacitor. The capacitor value can be increased without limit.

The SPX1521, unlike other low dropout regulators will remain stable and in regulation with no load in addition to the internal voltage divider. This feature is especially important in applications like CMOS RAM keep-alive.

If there is more than 10 inches of wire between the input and the AC filter capacitor, or if a battery is used as the input, then a 0.1μF tantalum or aluminum electrolytic capacitor should be placed from the input to the ground.

**Reducing Output Noise**

It may be an advantage to reduce the AC noise present at the output. One way is to reduce the regulator bandwidth by increasing the size of the output capacitor. Increasing the capacitor from 1μF to 220μF only decreases the noise from 430μV to 160μVrms for a 100kHz bandwidth at 5V output.

**PINOUTS**

Note: Tab is connected to GND

SOT-223 (M3)

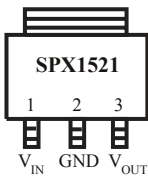

Top View

TO-263-3 (T)

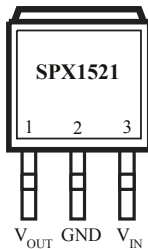

Top View

TO-220-3 (U)

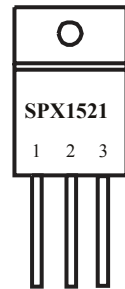

Front View

TO-252 (R)

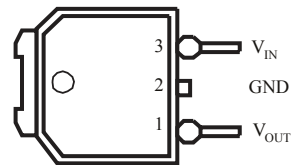

Front View

Thermal Resistance (Theta JA)

- SOT-223 -----62.3°C/W
- TO-262 -----31.4°C/W
- TO-220 -----29.4°C/W
- TO-252 -----50.0°C/W

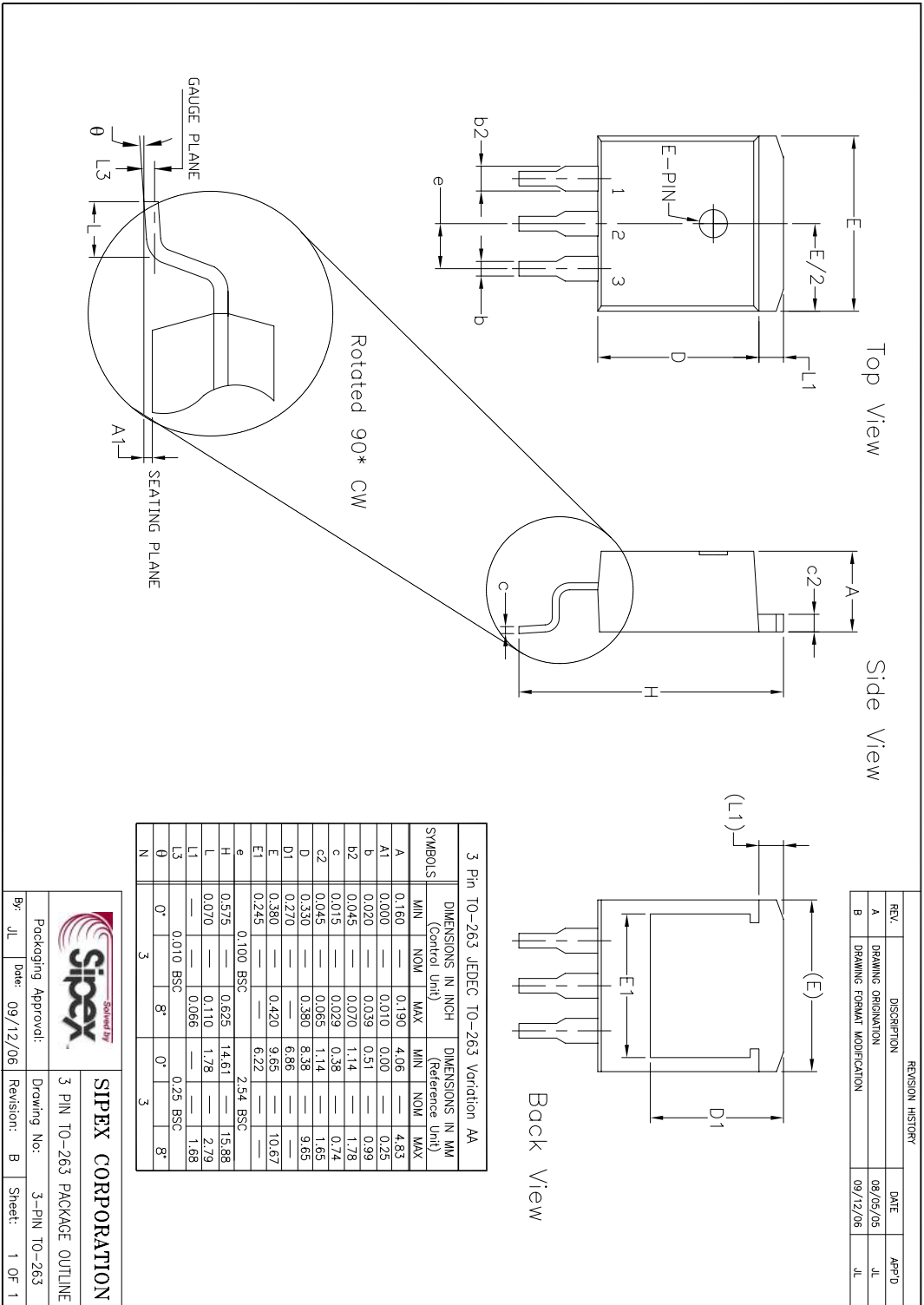

REVISION HISTORY			
REV.	DISCRIPTION	DATE	APP'D
A	DRAWING ORIGINATOR	08/05/05	JL
B	DRAWING FORMAT MODIFICATION	09/12/06	JL

SYMBOLS	DIMENSIONS IN INCH (Control Unit)			DIMENSIONS IN MM (Reference Unit)		
	MIN	NOM	MAX	MIN	NOM	MAX
A	0.160	—	0.190	4.06	—	4.83
A1	0.000	—	0.010	0.00	—	0.25
b	0.020	—	0.039	0.51	—	0.99
b2	0.045	—	0.070	1.14	—	1.78
c	0.015	—	0.029	0.38	—	0.74
c2	0.045	—	0.065	1.14	—	1.65
D	0.330	—	0.380	8.38	—	9.65
D1	0.270	—	—	6.86	—	—
E	0.380	—	0.420	9.65	—	10.67
E1	0.245	—	—	6.22	—	—
e	0.100	BSC	—	2.54	BSC	—
H	0.575	—	0.625	14.61	—	15.88
L	0.070	—	0.110	1.78	—	2.79
L1	—	—	0.066	—	—	1.68
L3	0.010	BSC	—	0.25	BSC	—
theta	0°	—	8°	0°	—	8°
N	3	—	—	3	—	—

		SIPEX CORPORATION	
		3 PIN TO-263 PACKAGE OUTLINE	
Packaging Approval:	By: JL	Drawing No:	Revision: B
Date: 09/12/06		3-PIN TO-263	Sheet: 1 OF 1

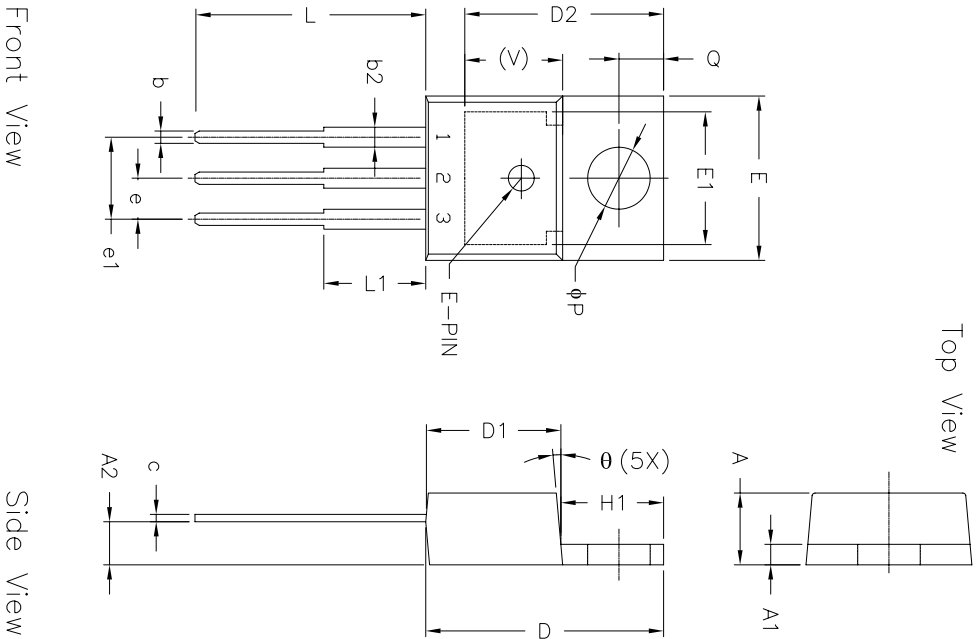

Top View

Front View

Side View

REVISION HISTORY			
REV.	DESCRIPTION	DATE	APP'D
A	DRAWING ORIGIN	09/04/05	JL
B	DRAWING FORMAT MODIFICATION	05/25/06	JL

3 Pin TO-220 (Option 1) * JEDEC TO-220-AB				
SYMBOLS	DIMENSIONS IN INCH (Control Unit)		DIMENSIONS IN MM (Reference Unit)	
	MIN	MAX	MIN	MAX
A	0.140	0.190	3.56	4.82
A1	0.020	0.055	0.51	1.40
A2	0.080	0.115	2.03	2.92
b	0.015	0.040	0.38	1.02
c	0.014	0.024	0.36	0.61
D	0.560	0.650	14.22	16.51
D1	0.330	0.355	8.38	9.02
D2	0.480	0.507	12.19	12.88
E	0.380	0.420	9.65	10.67
E1	0.270	0.350	6.86	8.89
e	0.100 BSC		2.54 BSC	
e1	0.200 BSC		5.08 BSC	
H1	0.230	0.270	5.84	6.86
L	0.500	0.580	12.70	14.73
L1	—	0.250	—	6.35
P	0.139	0.156	3.53	3.96
Q	0.103	0.113	2.62	2.87
V	0.240 REF		6.10 REF	
$\theta$	3°	7°	3°	7°
N	3	3	3	3

\* Refer to product datasheet for PDD option being used

		<b>SIPEX CORPORATION</b>	
Packaging Approval:	Date: 05/25/06	Drawing No:	Revision: B
By: JL	Date: 05/25/06	Drawing No:	Sheet: 1 OF 2

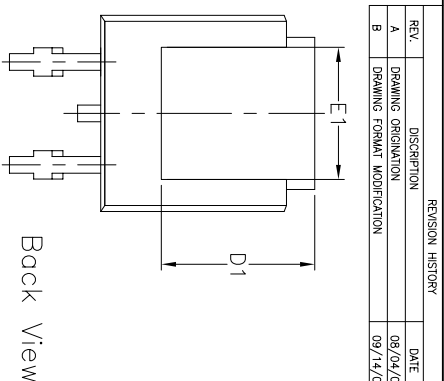
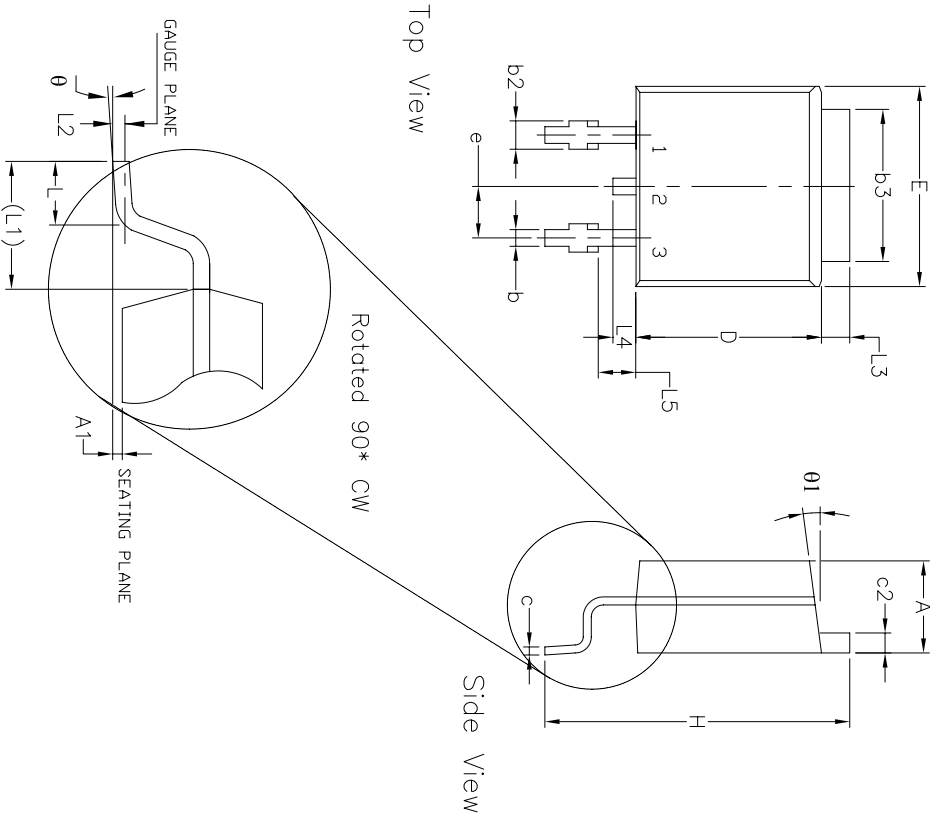

3 Pin TO-252 JEDEC TO-252 Variation AA

SYMBOLS	DIMENSIONS IN INCH (Control Unit)			DIMENSIONS IN MM (Reference Unit)		
	MIN	NOM	MAX	MIN	NOM	MAX
A	0.086	0.094	2.18	2.39	MAX	
A1	—	0.005	—	0.13	—	—
b	0.025	0.035	0.64	0.89	—	—
b2	0.030	0.045	0.76	1.14	—	—
b3	0.195	0.215	4.95	5.46	—	—
c	0.018	0.024	0.46	0.61	—	—
c2	0.018	0.035	0.46	0.89	—	—
D	0.235	0.245	5.21	6.22	—	—
D1	0.205	—	5.21	6.10	6.22	—
E	0.250	—	6.35	—	6.73	—
E1	0.170	—	4.32	—	—	—
e	—	0.090 BSC	—	2.29 BSC	—	—
H	0.370	—	9.40	—	10.41	—
L	0.055	0.060	1.40	1.52	1.78	—
L1	—	0.108 REF	—	2.74 REF	—	—
L2	—	0.020 BSC	—	0.51 BSC	—	—
L3	0.035	—	0.89	—	1.27	—
L4	—	0.040	—	—	1.02	—
L5	0.045	—	1.14	—	1.52	—
theta	0°	10°	0°	10°	—	—
theta1	0°	15°	—	0°	15°	—
N	—	3	—	—	3	—

REVISION HISTORY			
REV.	DISCRIPTION	DATE	APP'D
A	DRAWING ORIGINATION	08/04/05	JL
B	DRAWING FORMAT MODIFICATION	09/14/06	JL

**SIPLEX CORPORATION**

3 PIN TO-252 PACKAGE OUTLINE

Packaging Approval:	Drawing No:	Revision:	Sheet:
By: JL Date: 09/14/06	3-PIN TO-252	B	1 OF 1

Top View

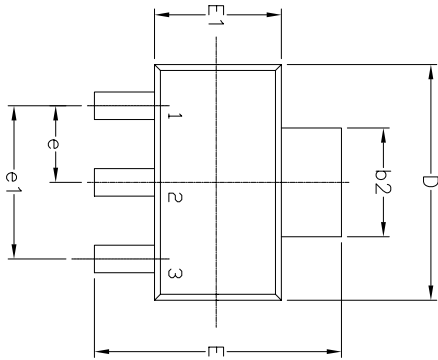

Side View

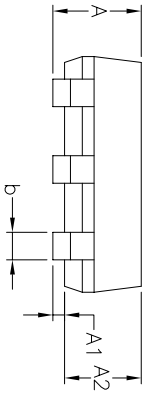

Front View

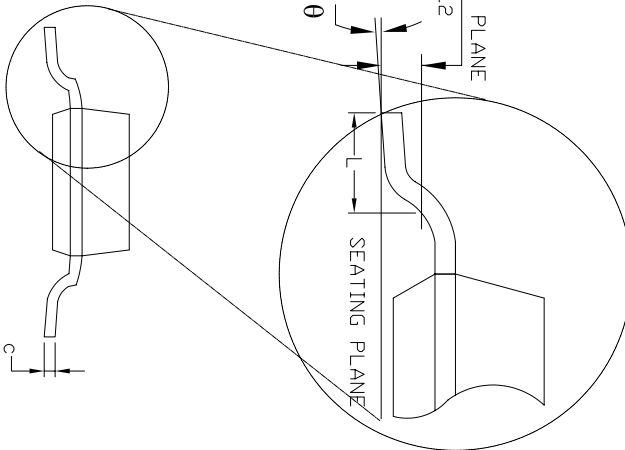

3 Pin SOT-223 JEDEC TO-261 Variation AA		DIMENSIONS IN MM		DIMENSIONS IN INCH		
SYMBOLS	MIN	NOM	MAX	MIN	MAX	
						(Control Unit)
A	—	1.80	—	—	0.071	
A1	0.02	—	0.10	0.001	—	
A2	1.50	1.60	1.70	0.060	0.067	
b	0.66	0.76	0.84	0.026	0.033	
b2	2.90	3.00	3.10	0.114	0.122	
c	0.23	0.30	0.35	0.010	0.014	
D	6.30	6.50	6.70	0.248	0.264	
E	6.70	7.00	7.30	0.264	0.287	
E1	3.30	3.50	3.70	0.130	0.146	
e	2.30 BSC		0.091 BSC			
e1	4.60 BSC		0.182 BSC			
L	0.75	—	—	0.030	—	
L2	0.25 BSC		0.010 BSC			
theta	0°	—	10°	0°	10°	
N	3		3			

REVISION HISTORY			
REV.	DESCRIPTION	DATE	APP'D
A	DRAWING ORIGINATOR	08/08/05	JL
B	DRAWING FORMAT MODIFICATION	09/11/06	JL

		<b>SIPLEX CORPORATION</b>	
Packaging Approval:		Drawing No:	
By: JL		Revision: B	
Date: 09/11/06		Sheet: 1 OF 1	

Part Number	Package Code	RoHS	Status	Pack Type	Pack Qty
SPX1521M3-L-3-3	SOT-223-3	•	Active	Tube	78
SPX1521M3-L-5-0	SOT-223-3	•	Active	Tube	78
SPX1521M3-L-5-0/TR	SOT-223-3	•	Active	Tape & Reel	2500
SPX1521R-3-3	TO-252		EOL	Tube	77
SPX1521T-L-5-0	TO-263-3	•	EOL	Tube	50
SPX1521R-3-3/TR	TO-252		OBS	Tape & Reel	2500
SPX1521R-5-0	TO-252		OBS	Tube	77
SPX1521R-5-0/TR	TO-252		OBS	Tape & Reel	2500
SPX1521R-L-3-3	TO-252	•	OBS	Tube	77
SPX1521R-L-3-3/TR	TO-252	•	OBS	Tape & Reel	2500
SPX1521R-L-5-0	TO-252	•	OBS	Tube	77
SPX1521R-L-5-0/TR	TO-252	•	OBS	Tape & Reel	2500
SPX1521T-3-3	TO-263-3		OBS	Tube	50
SPX1521T-3-3/TR	TO-263-3		OBS	Tape & Reel	500
SPX1521T-5-0	TO-263-3		OBS	Tube	50
SPX1521T-5-0/TR	TO-263-3		OBS	Tape & Reel	500
SPX1521T-L-3-3	TO-263-3	•	OBS	Tube	50
SPX1521T-L-3-3/TR	TO-263-3	•	OBS	Tape & Reel	500
SPX1521T-L-5-0/TR	TO-263-3	•	OBS	Tape & Reel	500
SPX1521U-3-3	TO-220-3		OBS	Tube	50
SPX1521U-5-0	TO-220-3		OBS	Tube	50
SPX1521U-L-3-3	TO-220-3	•	OBS	Tube	50
SPX1521U-L-5-0	TO-220-3	•	OBS	Tube	50



**Sipex Corporation**

**Headquarters and  
Sales Office**  
233 South Hillview Drive  
Milpitas, CA 95035  
TEL: (408) 934-7500  
FAX: (408) 935-7600

Sipex Corporation reserves the right to make changes to any products described herein. Sipex does not assume any liability arising out of the application or use of any product or circuit described herein; neither does it convey any license under its patent rights nor the rights of others.