

QT-Brightek Chip LED Series

SMD 0606 RGB LED

Part No.: QBLP600-RGB5-2897

5: 5mA

2897: High Brightness Version



Table of Contents:

Introduction3
Electrical / Optical Characteristic (Ta=25 °C)4
Absolute Maximum Rating4
Characteristic Curves.....7
Solder Profile & Footprint.....9
Packing10
Labeling11
Ordering Information11
Revision History12
Disclaimer12

Introduction

Feature:

- Water clear lens
- Package in tape and reel
- Ultra bright 0606 LED package
- Common Anode
- InGaN technology for B/G
- AlInGaP technology for R
- Viewing angle: 140 deg typ.

Description:

These ultra bright 0606 RGB LEDs have a height profile of 0.80mm. Combination of high brightness output and small footprint, these LEDs are ideal for keypad backlighting, status indication, and color mixing applications.

Application:

- Status indication
- Back lighting application

Certification & Compliance:

- ISO9001
- RoHS Compliant



Dimension:

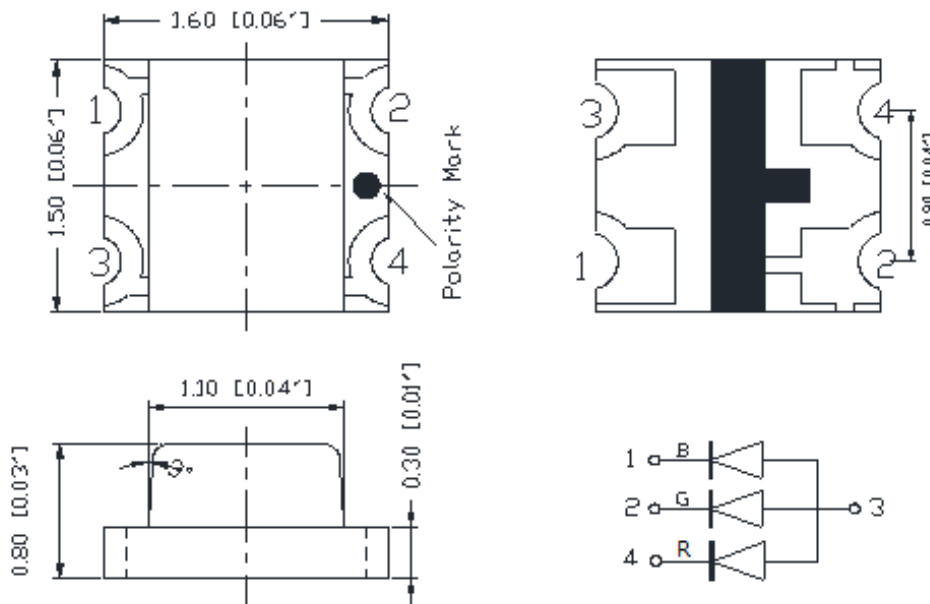

Units: mm / tolerance = +/-0.1mm

Electrical / Optical Characteristic (Ta=25 °C)

Product	Color	I _F (mA)	V _F (V)		λ _D (nm)			I _V (mcd)	
			Typ.	Max	Min	Typ.	Max	Min	Typ.
QBLP600-RGB5-2897	Red	5	1.9	2.3	615	620	630	20	38
	Green	5	2.8	3.1	525	528	535	125	240
	Blue	5	2.8	3.1	470	470	480	20	38

Absolute Maximum Rating

Material	P _d (mW)	I _F (mA)	I _{FP} (mA)*	V _R (V)	T _{OP} (°C)	T _{ST} (°C)	T _{SOL} (°C)**
AllnGaP (R)	69	30	125	5	-40 ~ +80	-40 ~ +85	260
InGaN (B/G)	93	30	125	5	-40 ~ +80	-40 ~ +85	260

*Duty 1/8 @ 1KHz

**IR Reflow for no more than 10 sec @ 260 °C

Forward Voltage V_F for AllnGaP @ I_F=5mA

Bin	Min.	Max.	Unit
□	1.7	2.3	V

Forward Voltage V_F for InGaN (B & G) @ I_F=5mA

Bin	Min.	Max.	Unit
A	2.6	2.9	V
B	2.9	3.2	

Luminous Intensity I_V @ $I_F=5mA$ for Red (R)

Bin	Min.	Max.	Unit
C	20	25	mcd
D	25	32	
E	32	40	
F	40	50	
G	50	63	

Luminous Intensity I_V @ $I_F=5mA$ for Green (G)

Bin	Min.	Max.	Unit
K	125	160	mcd
L	160	200	
M	200	250	
N	250	320	
O	320	400	

Luminous Intensity I_V @ $I_F=5mA$ for Blue (B)

Bin	Min.	Max.	Unit
C	20	25	mcd
D	25	32	
E	32	40	
F	40	50	
G	50	63	

Dominant Wavelength λ_D for Red @ $I_F=5mA$

Bin	Min.	Max.	Unit
s	615	620	nm
t	620	625	
u	625	630	

Dominant Wavelength λ_D for Green @ $I_F=5mA$

Bin	Min.	Max.	Unit
W	525	527.5	nm
X	527.5	530	
Y	530	532.5	
Z	532.5	535	

Dominant Wavelength λ_D for Blue @ $I_F=5mA$

Bin	Min.	Max.	Unit
I	465	467.5	nm
J	467.5	470	
K	470	472.5	
L	472.5	475	

Characteristic Curves

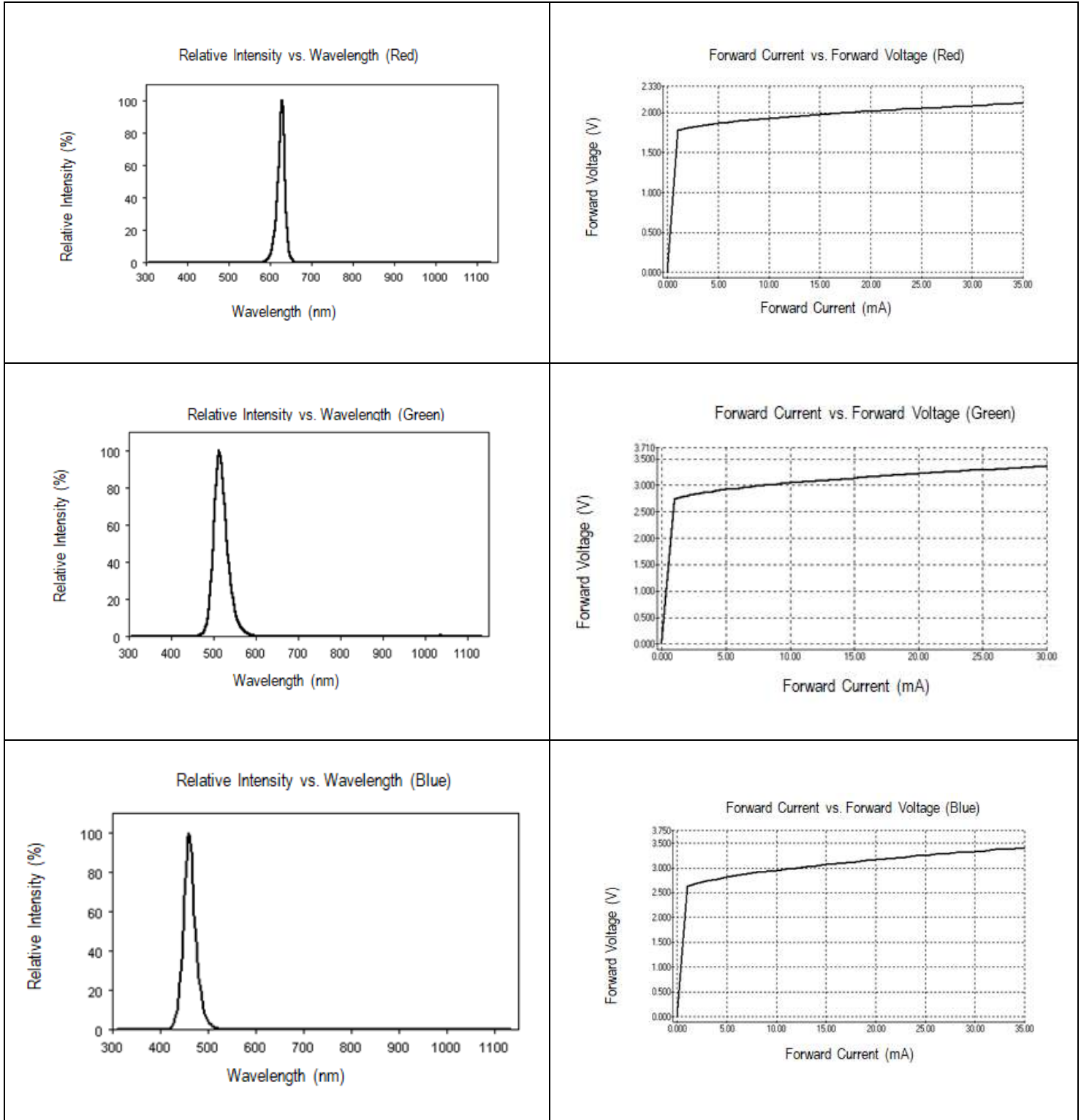

Directive Characteristics

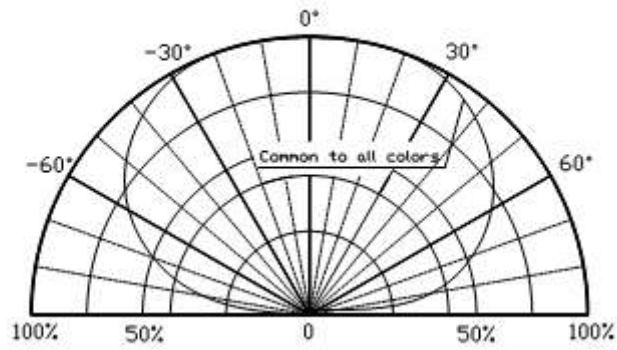

Solder Profile & Footprint

-The recommended reflow soldering profile is as follows (temperatures indicated are as measured on the surface of the LED resin):

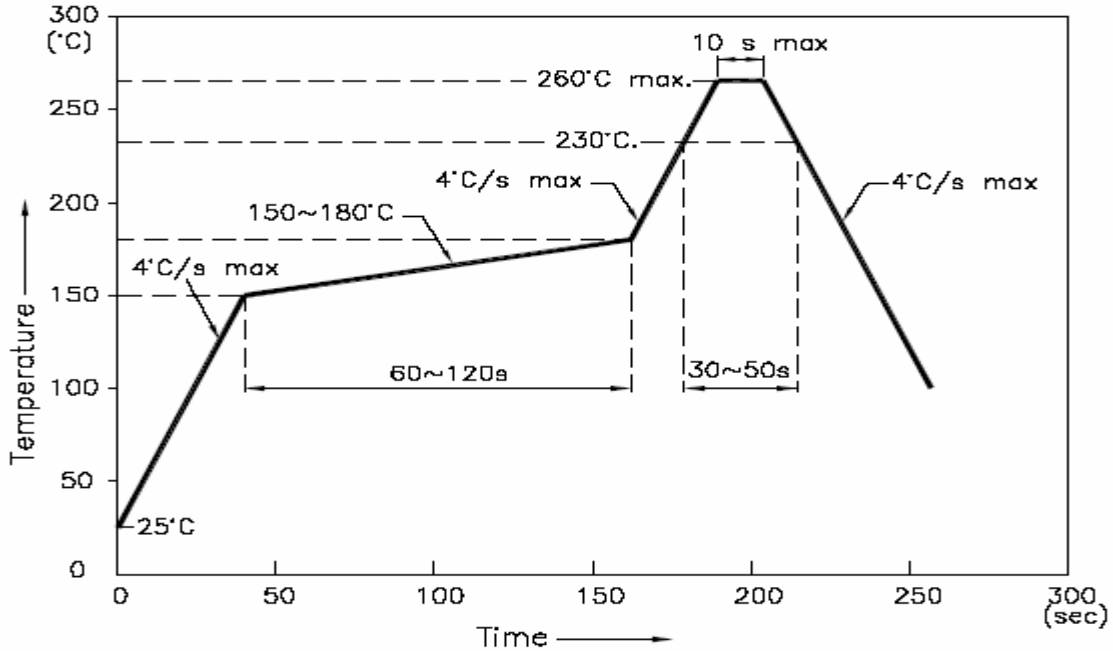

Recommended Pad Layout

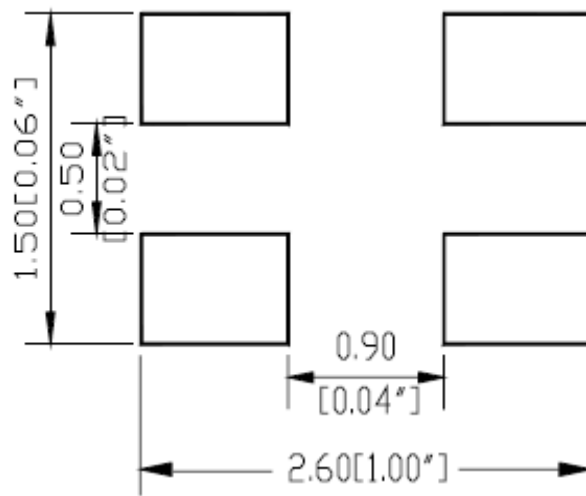

Units: mm

Packing

Reel Dimension:

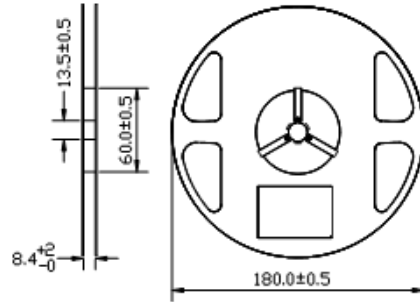

Unit: mm

Tape Dimension:

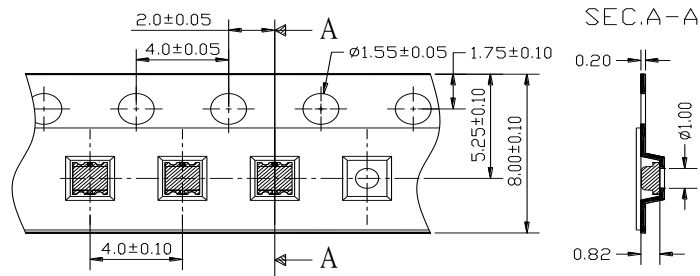

Unit: mm

Arrangement of Tape:

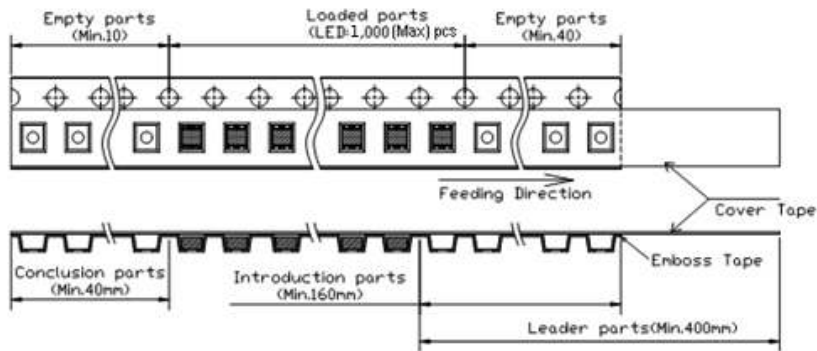

Packaging Specification:

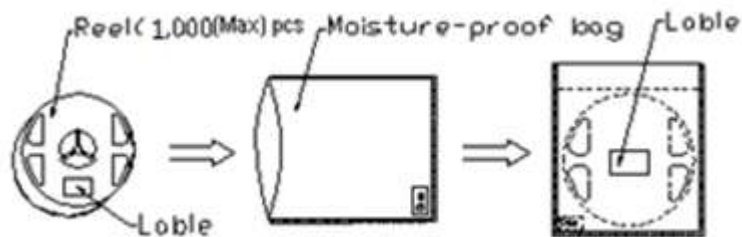

Labeling

Part No: _____

Customer P/N: _____

Item: _____

Q'ty: _____

Vf: _____

Iv: _____

WI: _____

Date: _____

Made in China**Ordering Information**

Part #	Orderable Part #	Spec Range	Quantity per reel
QBLP600-RGB5-2897	QBLP600-RGB5-2897	Red (R): Iv=38mcd typ. @ I _F =5mA, λ _D =615nm to 630nm	1,000 units
		Green (G): Iv=240mcd typ. @ I _F =5mA, λ _D =525nm to 535nm	
		Blue (B): Iv=38mcd typ. @ I _F =5mA, λ _D =470nm to 480nm	

Revision History

Description:	Revision #	Revision Date
New Release of QBLP600-RGB5-2897	V1.0	08/08/2022

Disclaimer

QT-BRIGHTEK reserves the right to make changes without further notice to any products herein to improve reliability, function or design. QT-BRIGHTEK does not assume any liability arising out of the application or use of any product or circuit described herein; neither does it convey any license under its patent rights, nor the rights of others.

Life Support Policy

QT-BRIGHTEK's products are not authorized for use as critical components in life support devices or systems without the express written approval of QT-BRIGHTEK. As used herein:

1. Life support devices or systems are devices or systems which, (a) are intended for surgical implant into the body, or (b) support or sustain life, and (c) whose failure to perform when properly used in accordance with instructions for use provided in the labeling, can be reasonably expected to result in a significant injury of the user.
2. A critical component in any component of a life support device or system whose failure to perform can be reasonably expected to cause the failure of the life support device or system, or to affect its safety or effectiveness.