

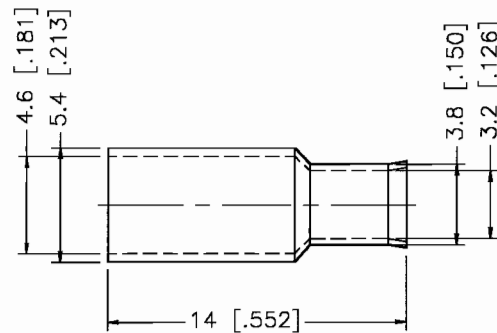

| REV. | DATE     | DESCRIPTION            |
|------|----------|------------------------|
| A    | 10/28/99 | MODIFY FERRULE PLATING |

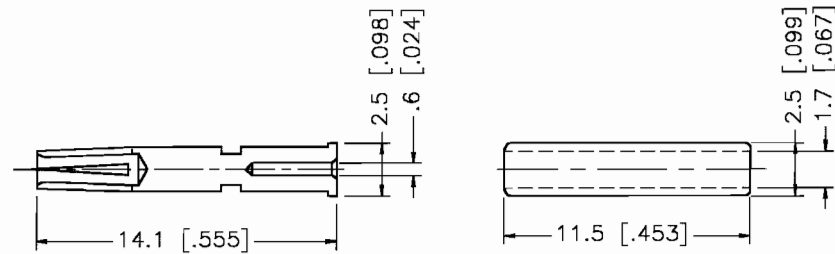
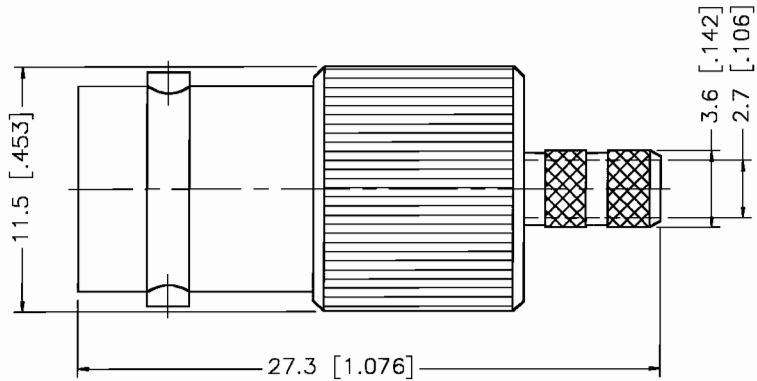
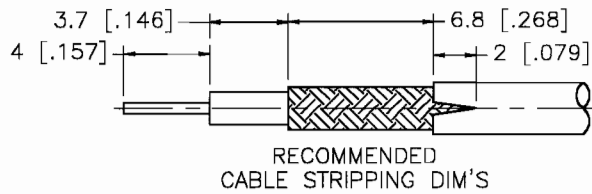

| DESCRIPTION | MATERIAL    | FINISH       | UNLESS OTHERWISE SPECIFIED<br>DIMENSIONS ARE IN MILLIMETERS | APPROVALS | DATE   |  |             |  |                    |          |   |  |
|-------------|-------------|--------------|---|-----------|--------|---|-------------|--|--------------------|----------|---|--|
| 1           | BODY        | BRASS        | NICKEL  | DRAWN     | G.R.S. |   |             |  |                    | 10/25/99 | TITLE<br>BNC STRAIGHT CRIMP JACK<br>(FOR RG-316/U DOUBLE BRAID CABLE) |  |
| 2           | INSULATOR   | DELKIN       | NATURAL   | CHECKED   |        |   | SIZE<br>A   |  |                    |          |   |  |
| 3           | CONTACT PIN | PHOS. BRONZE | GOLD  | ISSUED    |        |   |             |  |                    |          | FSCM NO.<br>99001   |  |
| 4           | SLEEVE      | DELKIN       | NATURAL   |           |        |   | SCALE<br>NA |  | PART NO.<br>112529 |          | SHEET<br>1 OF 1   |  |
| 5           | FERRULE     | BRASS        | NICKEL  |           |        |   |             |  |                    |          |   |  |
| 6           |             |              |   |           |        |   |             |  |                    |          |   |  |
| 7           |             |              |   |           |        |   |             |  |                    |          |   |  |
| 8           |             |              |   |           |        |   |             |  |                    |          |   |  |

DIMENSIONS IN [ ] ARE IN INCHES  
FOR CUSTOMER REFERENCE ONLY

UNLESS OTHERWISE SPECIFIED  
TOLERANCES FOR MILLIMETERS ARE:

0.5-6 = ± 0.2  
6-30 = ± 0.4  
30-120 = ± 0.6  
120-315 = ± 1  
315-1000 = ± 1.6  
1000-2000 = ± 2.4

DO NOT SCALE DRAWING