VARIANT 14 PUSH-PULL ASSEMBLY FOR SEVERAL COMMON CORES



PRJ-13-000001658

Variant 14 PushPull

for Automation & Control

(108-94207-1)

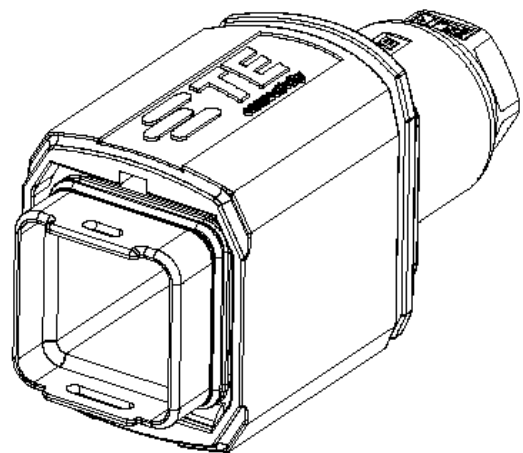
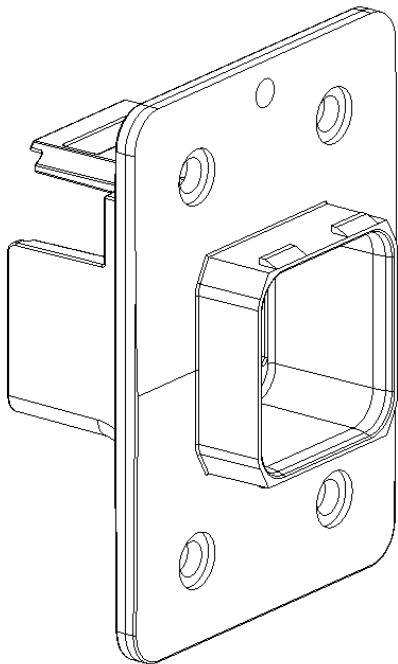

1. SCOPE

1.1 Content

This specification covers the performance, tests and quality requirements for Variant 14 Push-Pull Assembly Plug / Jack with several common cores via IEC 61076-3-117.

RJ45 Plug, Push Pull Assy

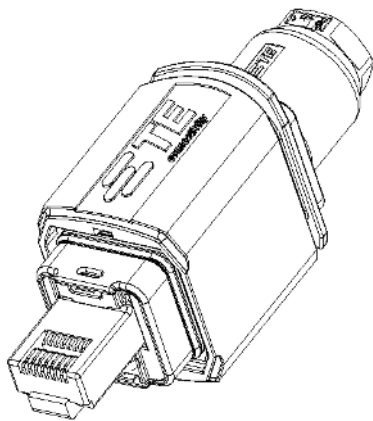

Fig. A1

RJ45 Jack, Push Pull Assy

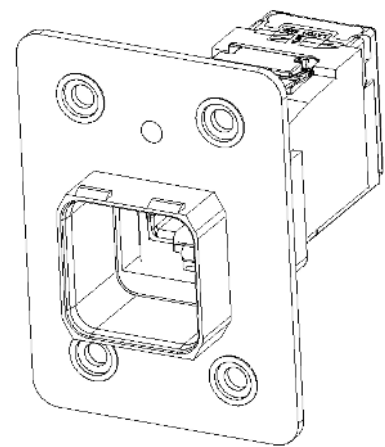

Fig. A2

Fiber Optic, Push Pull Assy

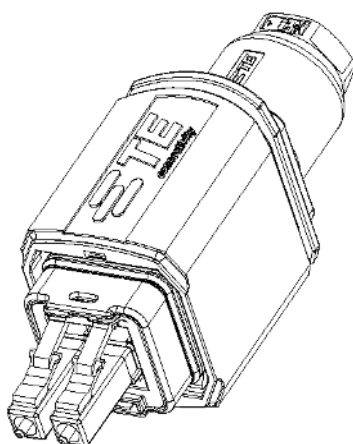

Fig. B1

Fiber Optic, Push Pull Assy

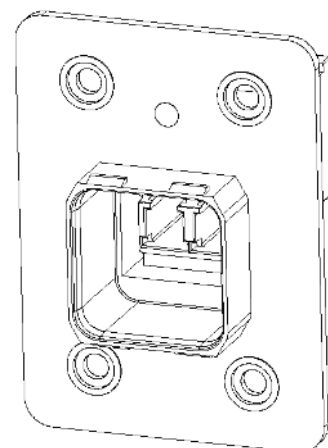

Fig. B2

1.2 Qualification

The following given specifications and standards shall be used when performing the tests. All tests shall be performed by using the applicable inspection plans and product drawings.

2. APPLICABLE DOCUMENTS

The following documents are part of this specification, if they are referenced. In case of conflict between this specification and the product drawing or of conflict between this specification and the referenced documents, this specification shall take precedence.

2.1 Tyco Electronics Documents

A Test Specification

- 109-1: General requirements for test specifications
- 108-78381: Industrial Ethernet RJ45 Connector
- 408-8925: LightCrimp plus LC Fiber Optic Connector Kits

B Drawings

- C-1987004 RJ45 Plug, Push-Pull, Assy, Cat5, Shielded
- C-2120864 Variant 14; Plug with RJ45
- C-2120871 Variant 14; Jack with RJ45
- C-2120875 Variant 14; coupler Plug and Jack

2.2 Other Documents

IEC 60068-1	1988 Environmental testing. Part 1: General and guidance
IEC 60068-2-14	1984 Environmental testing - Part 2: Tests. Test N: Change of temperature.
IEC 60068-2-30	2005 Environmental testing - Part 2-30: Tests - Test Db: Damp heat, cyclic (12 h + 12 h cycle)
IEC 60512-1	2001 Connectors for electronic equipment - Tests and measurements - Part 1: General
IEC 60512-2-5	2003 Connectors for electronic equipment - Tests and measurements - Part 2-5: Electrical continuity and contact resistance tests - Test 2e: Contact disturbance
IEC 60512-6-3	2002 Connectors for electronic equipment - Tests and measurements - Part 6-3: Dynamic stress tests - Test 6c: Shock
IEC 60512-6-4	2002 Connectors for electronic equipment - Tests and measurements - Part 6-4: Dynamic stress tests - Test 6d: Vibration
IEC 60512-9	1992 Electromechanical components for electronic equipment; basic testing procedures and measuring methods - Part 9: Miscellaneous tests
IEC 60512-13-1	2006 Connectors for electronic equipment - Tests and measurements - Part 13-1: Mechanical operation tests - Test 13a: Engaging and separating forces

IEC 60512-15-6	2006 Connectors for electronic equipment - Tests and measurements - Part 15-6: Connector tests (mechanical) - Test 15f - Effectiveness of connector coupling devices
IEC 60512-9-1	Connectors for electronic equipment - Tests and measurements - Part 9-1: Endurance tests - Test 9a - Mechanical operation
IEC 60529	1999 Degrees of protection provided by enclosures (IP Code)
EN 61754-24-11	Fiber optic connector interfaces – Interface standard for SC-RJ connectors with protective housings

3. REQUIREMENTS

3.1 Design and construction

Product shall be of the design, construction and physical dimensions specified on the applicable product drawing

3.2 Materials

The materials used for the product are free of Silicone or Silicone contained release agents and free of unbound Teflon. See drawings for further information and details.

3.3 Ratings

A	Operating temperature	-40°C ... +70°C
B	Storage temperature	-40°C ... +70°C
C	Degree of protection	IP65 / IP67
D	Signal integrity	acc. Fiber optic Specification
E	Electrical properties	see Industrial Ethernet RJ45 Connector Specification
F	Dimension of Plug	58mm x 29mm x 23mm
G	Dimension of Jack	52mm x 38mm x 28mm

Electrical characteristics see Specification of Industrial Ethernet RJ45 Connector and Fibre Optic

3.4 Performance and Test Description

The product is designed to meet the electrical, mechanical and environmental performance requirements specified in paragraph 3.5. All tests are performed at ambient environmental conditions per IEC 60512-2 unless specified otherwise.

3.5. Test requirements and Procedures

No.	Test Description	Requirement	Test Procedure
General Inspections			
1	Visual and dimensional examination	Meets requirements of product drawing. There shall be no defect that would impair normal operation.	According to IEC 60512-1, test 1a and 1b
Electrical Inspections			
2	Contact resistance ⁽⁴⁾	Measuring points see IEC60603-7 Signal contact: max. 20mOhm Shield contact: max. 100mOhm	According to IEC 60512-2-1 in connected condition
3	Insulation resistance	R > 500MOhm 100V ± 15V	According to IEC 60512-3-1 in connected condition
4	Dielectric strength	1000V DC	According to IEC 60512-4-1 in connected condition
Mechanical Inspections			
5	Separation and insertion forces	Rate: 50 mm/min Insertion force: 45N max. Separation force: 30N max.	According to IEC 60512-13-1
6	Effectiveness of coupling device	Rate of load: max. 44,5 N/s 50 N for 60s ± 5s No electrical disconnection permitted	According to IEC 60512-15-6
7	Mechanical operation ⁽³⁾	750 cycles - see mechanical operation Max. speed 10mm/s; rest 5s	According to IEC 60512-9
8	Vibration	f= 10-500Hz, Amplitude= 0,35 mm, acceleration = 50m/s ² at room temperature 10 sweeps /axis	According to 60512-6-4 test 6d contact disturbance max.1µs According to IEC 60512-2-5 test 2e

9	Shock	50g, 11ms duration of impact, Acceleration = 500m/s ² Half sinusoidal at room temperature 3 shocks /axis	According to IEC 60512-6-3 contact disturbance: max.1μs / 7Ω According to IEC 60512-2-5
10	Cable retention force	89N by cable Ø 6.0mm – 8.0mm Duration: 60s No contact with alive parts permitted	UL 1703, test 22
11	Retention force	Test forces: 20N Duration: 60s No physical damage	IEC 60512- (1) adapter used in the Plug (2) adapter used in the Frame
Environmental Inspections			
12	Rapid change of Temperature	No physical damage -40°C to +70°C mated connector, t=0.5h each 25 cycles	According to IEC 60068-2-14, Na
13	Degrees of protection (IP-Code) First reference number	Class IP6x Dust with vacuum	According to IEC 60529
14	Degrees of protection (IP-Code) Second reference number	Class IPx5 Hose water; cone: 6.3mm Class IPx7 Diving; 1m for 0.5h	According to IEC 60529
15	Degrees of protection (IP-Code) Second reference number	Class IPx8 Diving; 1m for 1h	According to IEC 60529 OPTIONAL
16	Degrees of protection (IP-Code) Second reference number	Class IPx9K 80°C / 80bar	According to IEC OPTIONAL OPTIONAL

3.5. Qualification and Requalification Tests Sequence

No.	Test	Test group ⁽¹⁾								
		A	B	C	D	E	F	G	H	I
		Test sequence ⁽²⁾								
1	Visual and dimensional examination	1, 9	1, 9	1, 10						
2	Contact resistance ⁽⁴⁾	2, 4, 6								
3	Insulation resistance		6							
4	Dielectric strength		7							
5	Separation and engagement forces			2						
6	Effectiveness of coupling device	8		3, 5						
7	Mechanical operation ⁽³⁾			4						
8	Vibration	3								
9	Shock	5								
10	Cable retention force		8							
11	Retention force			6						
12	Rapid change of Temperature		3	8						
13	Degrees of protection (IP6x)		5							
14	Degrees of protection (IPx5 / IPx7)	7	2, 4	7, 9						
15	Degrees of protection (IPx8) OPTIONAL		4a							
16	Degrees of protection (IPx9K) OPTIONAL		4b							

- (1) See paragraph 4.1 A
- (2) Numbers indicate sequence in which tests are performed.
- (3) After test, traces of usage are allowed.
- (4) Wire resistance subtracted from the overall resistance

4. QUALITY ASSURANCE PROVISIONS

4.1 Qualification Testing

A Sample selection

The samples shall be prepared in accordance with product drawings. They shall be selected at random from the production.

Test groups consist of:

Test group A	3pcs	Variant 14 Plug with RJ45, 8pos	PN: 2120864-1
	3pcs	Variant 14 Jack metal CAT 5e, Pass Through	PN: 2120871-1
	3pcs	Variant 14 Plug with FO, LC, Single Mode	PN: 3-2120864-1
	3pcs	Variant 14 Jack with FO, LC Single Mode	PN: 3-2120871-1
Test group B	6pcs	Variant 14 Plug with RJ45, 8pos	PN: 2120864-1
	6pcs	Variant 14 Jack metal CAT 5e, Pass Through	PN: 2120871-1
Test group C	3pcs	Variant 14 Plug with RJ45, 8pos	PN: 2120868-1
	3pcs	Variant 14 Jack metal CAT 5e, Pass Through	PN: 2120871-1
	3pcs	Variant 14 Plug (for mechanical operation only)	PN: 2120886-1
	3pcs	Variant 14 Jack (for mechanical operation only)	PN: 2120869-1

B Test sequence

Qualification inspection shall be verified by testing samples as specified in paragraph 3.6.

4.2 Requalification Testing

If changes affecting significantly form, fit or function are made to the product or to the manufacturing process, product assurance shall coordinate requalification testing, consisting of all or part of the original testing sequence as determined by development/product, quality, and reliability engineering.

4.3 Acceptance

Acceptance is based on verification that the product meets the requirements of paragraph 3.5. Failures attributed to equipment, test setup, or operator deficiencies shall not disqualify the product.

When product failure occurs, corrective action shall be taken and samples are resubmitted for qualification. Testing to confirm corrective action is required before resubmittal.

4.4 Quality and Conformance Inspection

The applicable TE quality inspection plan will specify the sampling acceptable quality level to be used. Dimensional and functional requirements shall be in accordance with the applicable product drawing and this specification.

A APPENDIX

A.1 Test Setup for Mechanical Vibration Test and Mechanical Shock Test

Refer to test No. 8 on page 7 and to test No. 9 on page 8

For the mechanical and vibration test, it is important to fix the Specimens on a fixing plate. Fix the cable and the screw according to fig. C1

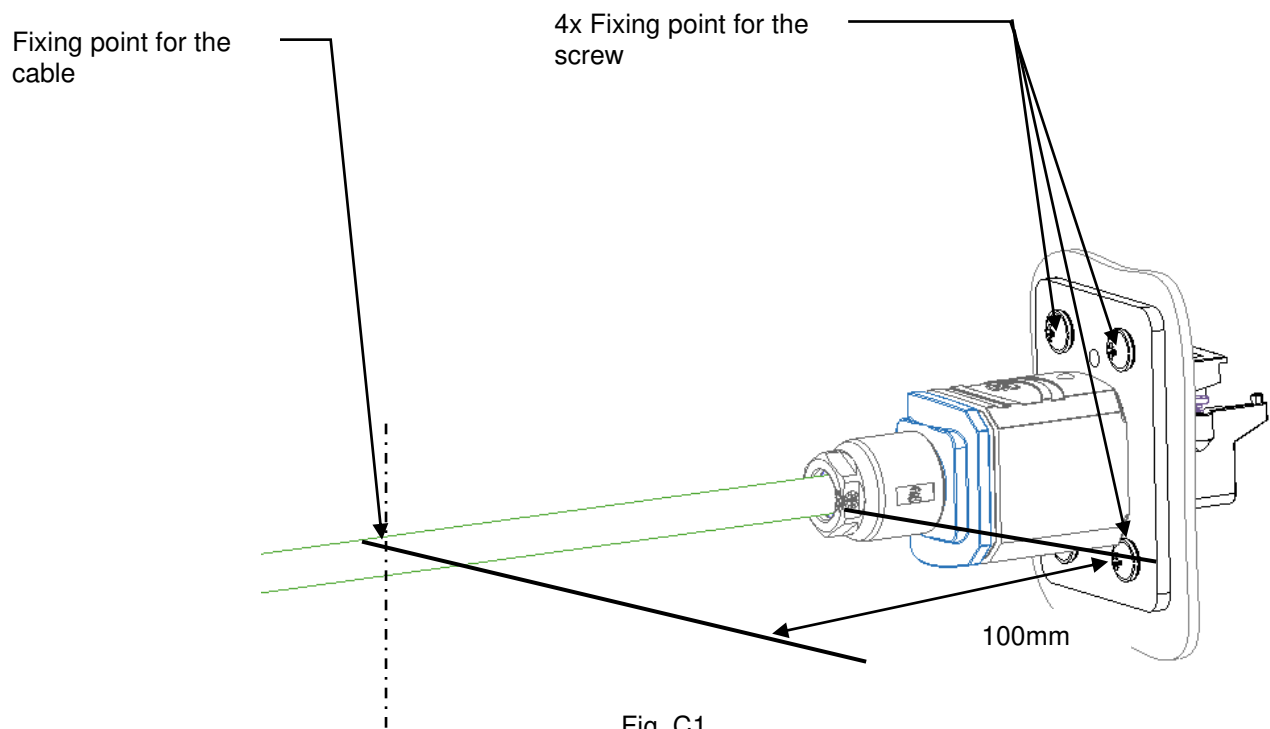

A.2 Test Setup for Cable Retention Force

Refer to test No. 10 on page 8

For the Cable Retention Force test, it is important to test without connection to common cores. Also the PushPull connector have to fix that by test procedure no influence of connector comes in. Before test can start cable screw joint prepared to tighten to a torque of $1.4\text{Nm} \pm 0.1\text{Nm}$. Test on cable according fig. C2

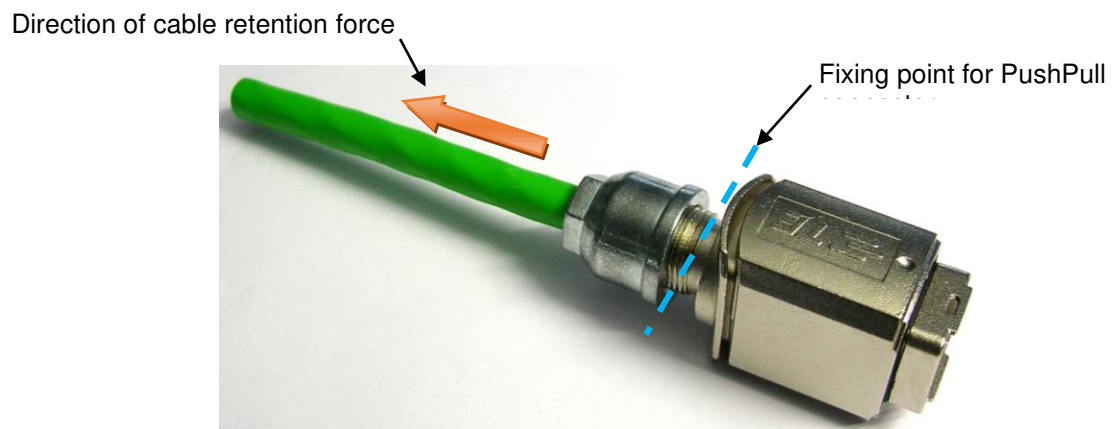

Fig. C2

A.3 Test Setup for Adapter Retention Force on Plug and Frame

Refer to test No. 11 on page 8

For the Retention Force test, it is important to test without connected cables or counterpart. Test according to fig. C3 and C4

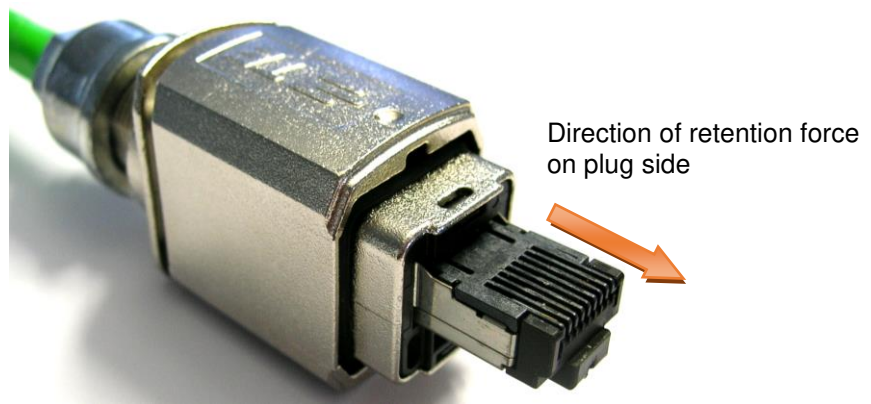

Fig. C3

Direction of retention force on frame side

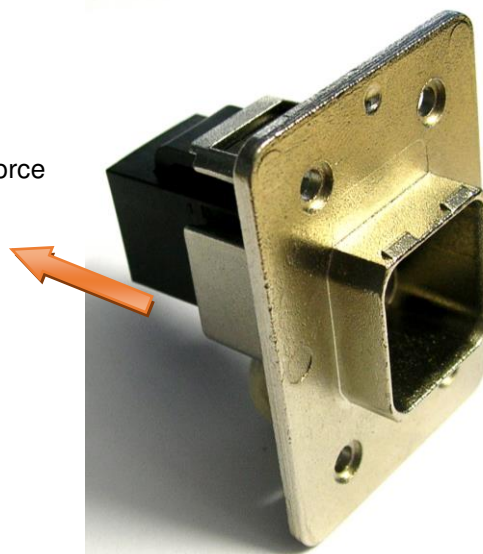

Fig. C4