



All numerical values are in metric units [with U.S. customary units in brackets]. Dimensions are in millimeters [and inches]. Unless otherwise specified, dimensions have a tolerance of ± 0.13 [$\pm .005$] and angles have a tolerance of $\pm 2^\circ$. Figures and illustrations are for identification only and are not drawn to scale.

1. INTRODUCTION

This specification covers the requirement for application of 1.0 mm FH Plug and Receptacle Connectors for surface mount printed circuit (pc) board applications. These plug and receptacle connectors have solder tines spaced on 1 mm [.039 in.] centers and are available in (IEEE Standard) 64- or optional 84-position versions. The connectors can be positioned by hand or by robotic equipment and are designed for board stacking applications that have 8 stacking heights from 8.0 mm [.315 in.] to 15.0 mm [.591 in.].

When corresponding with personnel, use the terminology provided in this specification to facilitate your inquiries for information. Basic terms and features of this product are provided in Figure 1.

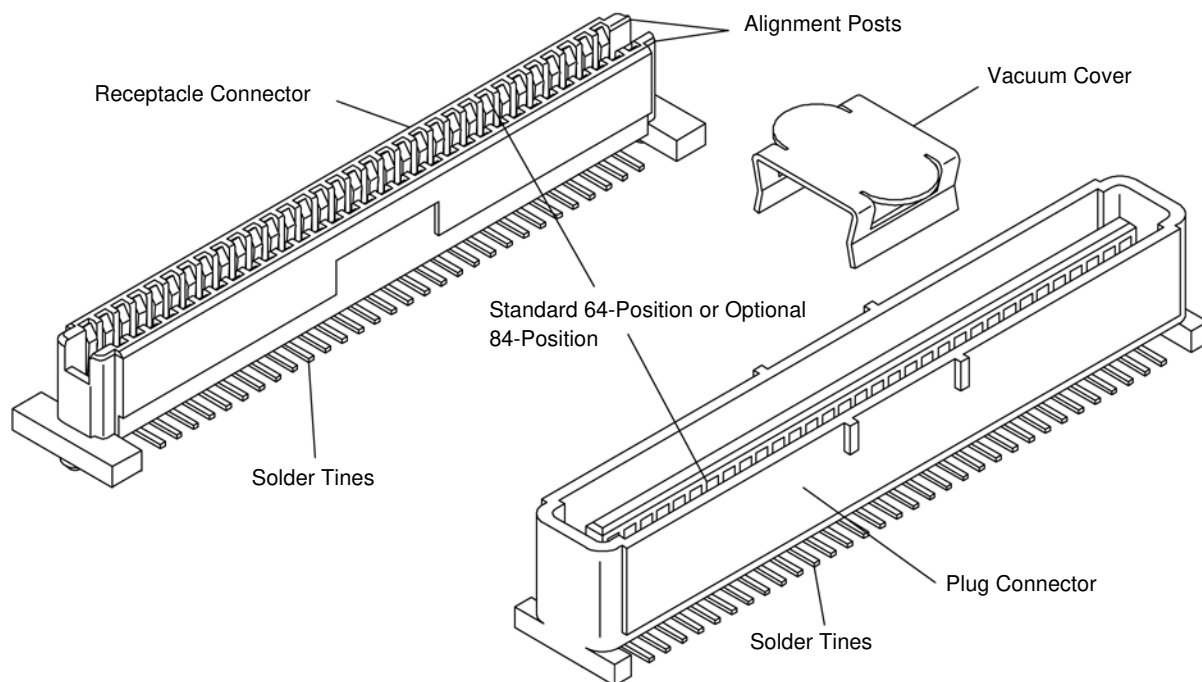

Figure 1

2. REFERENCE MATERIAL

2.1. Revision Summary

This paragraph is reserved for a revision summary covering the most recent additions and changes made to this specification. Most recently, the company logo was changed. The new company logo is reflected on this specification :

2.2. Customer Assistance

Reference Part Number 120521 and Product Code 6537 are representative numbers of 1.0 mm FH Plug and Receptacle Connectors. Use of these numbers will identify the product line and expedite your inquiries through a service network established to help you obtain product information. Such information can be obtained through a local Tyco Electronics Representative or, after purchase, by calling the Tooling Assistance Center or the Product Information Center number at the bottom of this page.

2.3. Drawings

Customer drawings for each connector are available from the service network. The information contained in customer drawings takes priority if there is a conflict with this specification or with any technical documentation supplied by TE.

2.4. Agency Specifications

EIA-364-52, EIA-700AAAB, and IEEE 1386 provide requirements and evaluation methods.

2.5. Manuals

Manual 402-40 is available upon request and can be used as a guide in soldering. This manual provides information on various flux types and characteristics along with the commercial designation and flux removal procedures. A checklist is attached to the manual as a guide for information on soldering problems.

3. REQUIREMENTS

3.1. Storage

A. Ultraviolet Light

Prolonged exposure to ultraviolet light may deteriorate the chemical composition used in the connector housing material.

B. Shelf Life

Connectors are packaged and shipped on reels inside EIA-481 carrier tape. To prevent damage to the housings and contacts, the connectors should remain in the container until ready for installation. Also, to prevent possible storage contamination and ensure maximum solderability for SMT solder tines, the connectors should be used on a first in, first out basis.

C. Chemical Exposure

Do not store connectors near any chemical listed below as they may cause stress corrosion cracks in the contacts.

Alkalies	Ammonia	Citrates	Phosphates	Citrates	Sulfur Compounds
Amines	Carbonates	Nitrites	Sulfur Nitrites		Tartrates

3.2. Product Materials

FH Connector Housings are constructed of high temperature thermoplastic - Liquid Crystal Polymer, UL94V-0. The plug and receptacle contacts are made of phosphor bronze with the mating interface of the contacts underplated with nickel and finished with gold plating. The solder tines have 93/7 matte tin-lead plating.

3.3. Circuit Identification

1.0 mm FH Plug and Receptacle Connectors are not polarized with respect to either the X or Y axis, and therefore pin 1 location is arbitrary. Pin layout is to be established by the OEM.

3.4. Spacing

A. Connector Alignment

Connectors can be placed in close proximity to each other on the pc board. The dimensions provided do NOT include space needed for other pc board components or robotic tooling. Check spacing requirements for other components before making your placement layout on the pc board. Figure 2 provides recommended placement variations to ensure vertical board-to-board plug and receptacle mating and unmating.



Careful consideration to the tolerances must be observed when more than one connector pair is to be used between pc boards. Tolerance build-up on the pc board in conjunction with the tolerances associated with placing the connectors could cause a stress load on the solder joints which could affect their reliability. Consult Tyco Electronics Engineering by calling one of the telephone numbers at the bottom of page 1.

B. Board Stacking Heights

Board stacking heights for the 1.0 mm FH Connectors are provided in Figure 3.



The dimension provided does not include the paste thickness between the solder tines and solder pads of both connectors.

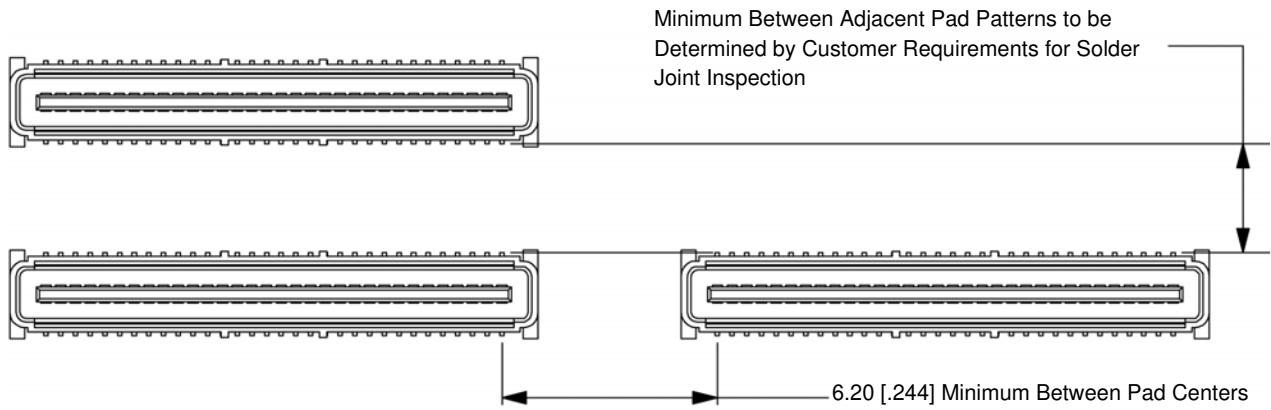

Figure 2

The system should be designed with support for the pc boards to minimize stress on the solder tines of surface-mounted connectors.



The distance between pc boards will be determined by the dimension needed for fully mated connectors as provided in Figure 3. However, we emphasize that the connectors **MUST NOT** be used as the only standoff between pc boards.

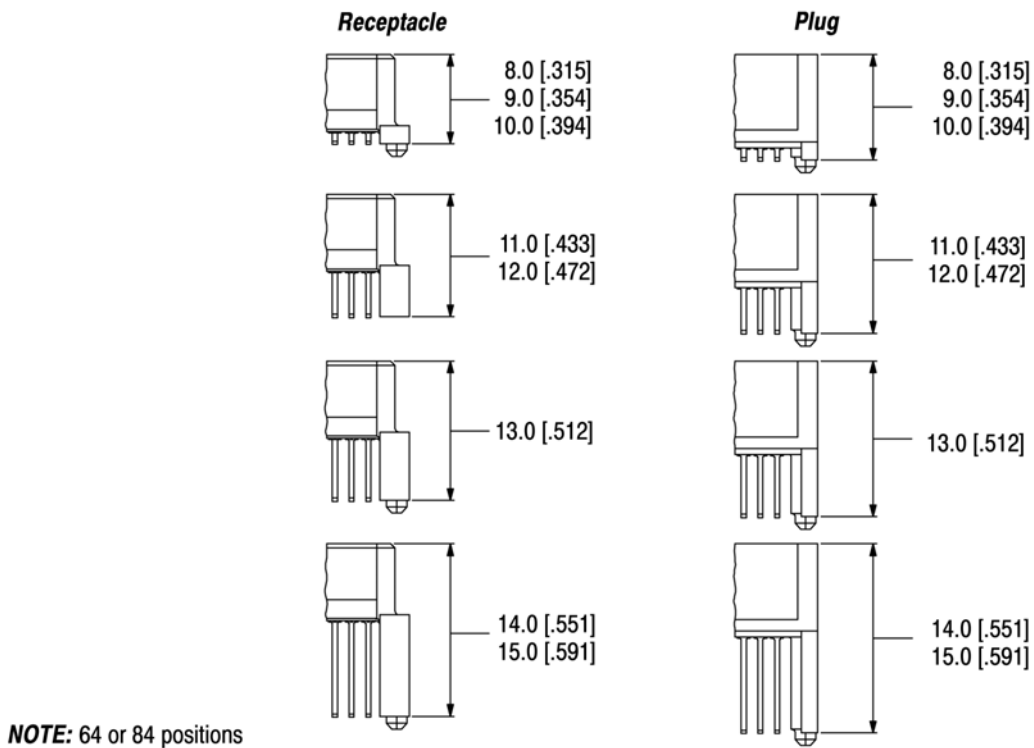
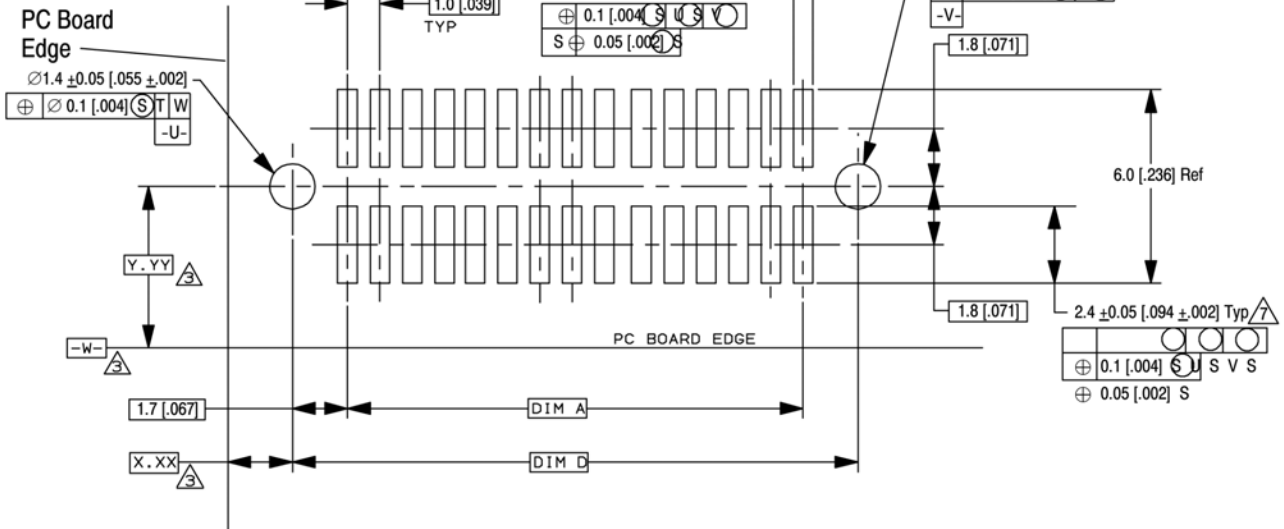
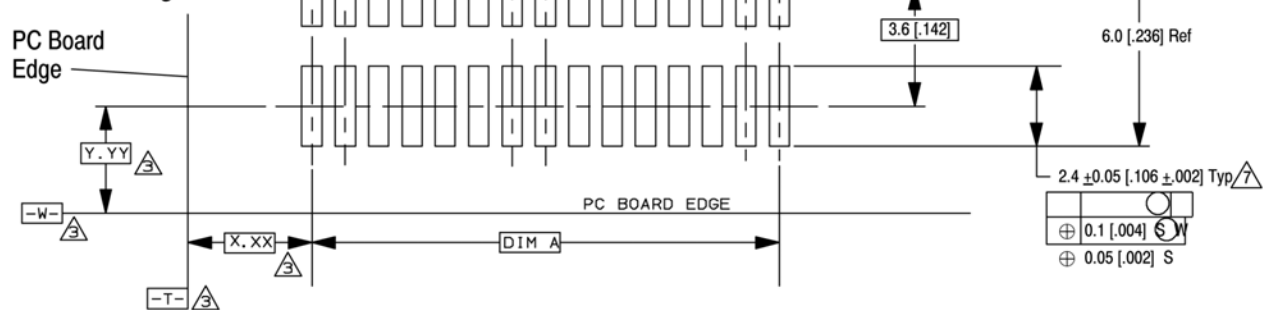

Figure 3

Receptacle Board Layout with Locating Posts

Receptacle Board Layout without Locating Posts

3 Datum locations and basic dimensions to be established by the customer. Consult Tyco Electronics when placing multiple connectors on a pc board.

5 $1.5 \pm 0.05 [0.059 \pm 0.002]$ diameter hole should be used if placed on pc board with vacuum placement equipment.

6 Shorter solder lands may be used per EIA-700 AAAB. However, $2.7 [0.106]$ length ensures optimum solder fillet regardless of connector manufacturer.

7 Shorter solder lands may be used per EIA-700 AAAB. However, $2.4 [0.094]$ length assures optimum solder fillet regardless of connector manufacturer.

NUMBER OF POSITIONS	DIMENSIONS	
	A	D
Standard 64	31.0 [1.220]	34.4 [1.354]
Optional 84	41.0 [1.614]	44.4 [1.748]

Figure 4 (End)

3.6. Processing

The pc boards must be solderable in accordance with EIA-364-52.

A. Typical Solder Paste Characteristics

- 1) Alloy type shall be either 63 Sn/37 Pb or 60 Sn/40 Pb.
- 2) Flux shall be RMA type.

B. Solder Volume

Solder volume for each component shall be:

- **Plug**.....0.303 mm³ [.0000185 in³] max
0.245 mm³ [.000015 in³] min per contact
- **Receptacle**.....0.262 mm³ [.000016 in³] max
0.213 mm³ [.000013 in³] min per contact

NOTE *Solder volume may vary depending on solder paste composition.*



C. Stencil

Stencil aperture will be determined by the thickness of the stencil being used. Generally, the thinner stencils will have a larger aperture to maintain a given volume of solder paste. Solder deposition should be within the pad area of the contact solder tines. Typical aperture openings and location of solder disposition are provided in Figure 5.

CAUTION *All traces must be covered by solder mask in the solder deposit area. Vias (non-component interlayer connection holes) must be adequately spaced from pads and separated by solder mask to avoid coverage by solder paste deposits. Exposed traces could cause bridging and create a short, or wick solder away from the solder tines, producing a weak solder joint.*

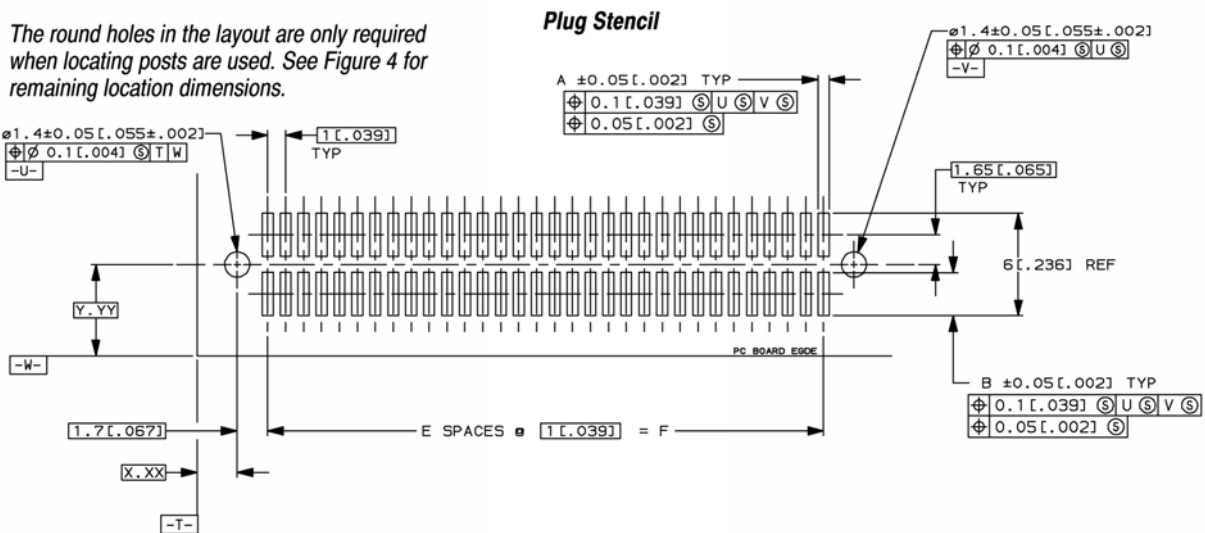



Stencil	Nominal Pad Size	Stencil			64-Position		84-Position	
		Thickness	A	B	E	F	E	F
Plug	0.6 x 2.7 [.024 x .106]	0.1 [.004]	0.8 [.032]	3.5 [.139]	63	31	83	41
		0.15 [.006]	0.7 [.028]	2.8 [.110]				
		0.2 [.008]	0.6 [.024]	2.5 [.098]				

Figure 5 (Cont'd)

Receptacle Stencil

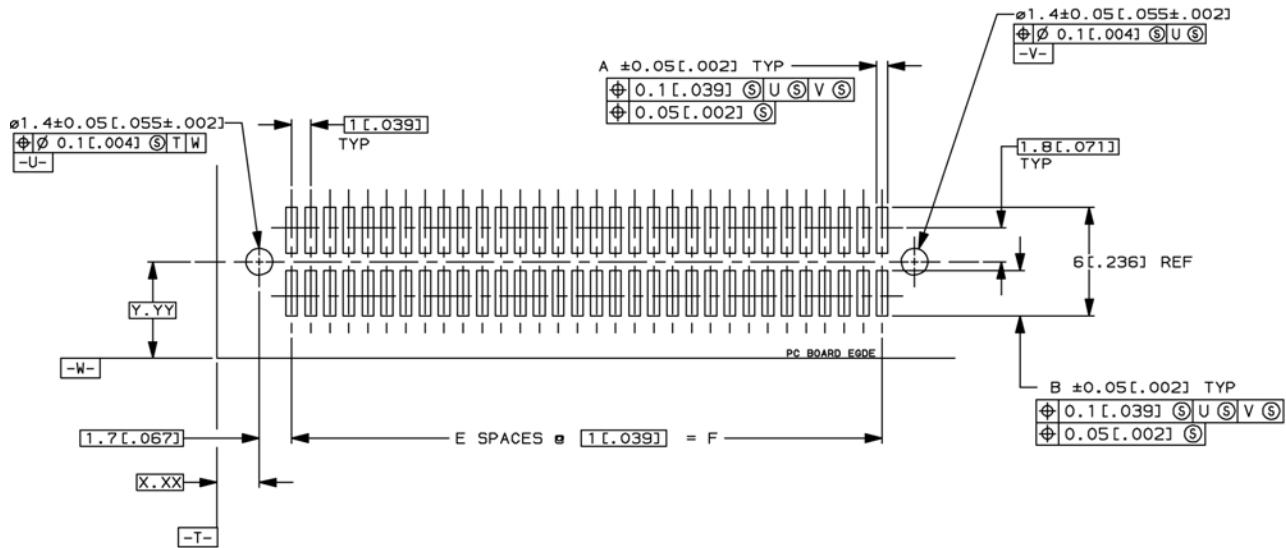
The round holes in the layout are only required when locating posts are used. See Figure 4 for remaining location dimensions.



Stencil	Nominal Pad Size	Stencil			64-Position		84-Position	
		Thickness	A	B	E	F	E	F
Receptacle		0.1 [.004]	0.8 [.032]	3.1 [.122]	63	31	83	41
		0.15 [.006]	0.7 [.028]	2.7 [.106]				
		0.2 [.008]	0.6 [.024]	2.1 [.083]				

Figure 5 (End)

D. Solder Mask

Solder mask is recommended between all pads. If a trace is run between adjacent pads on the solder side of the pc board, a solder mask must be applied over the trace to prevent bridging and wicking of solder away from the contact solder tines. Liquid photo imageable or dry film solder masks are recommended.

3.7. Connector Placement



Connectors are on tape reels and should be placed directly from the package to the pc board. We do NOT recommend emptying them from the package into piles or in bowl feeders prior to placement.

Connectors can be placed on the pc board by hand by gripping the connector at the ends of the housing without touching the contacts. This procedure will prevent contamination and deformation of the solder tines. They can also be positioned with robotic equipment using vacuum pickup or robotic grippers.

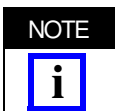

Care must be taken during positioning of the connectors on the pc board so as to not exceed the allowable misalignment absorption, as recommended by the EIA-700AAAB specification. See Figure 6. Values given are for the mated pair, and not for each connector. This requires each connector to be located within +0.07mm [.003 in.] of nominal center.

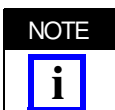

Optimally, the connector solder tines should be centered on the pc board pads. However, slight misregistration is permissible as long as the entire solder tine is on the pad with no overhang. See Figure 7.

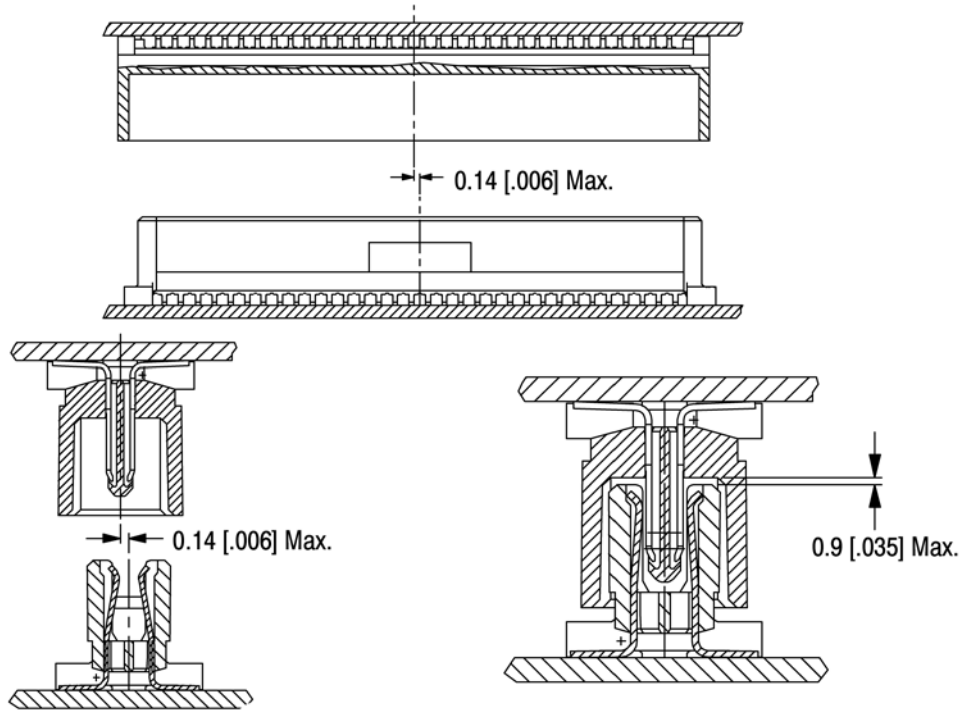

Figure 6

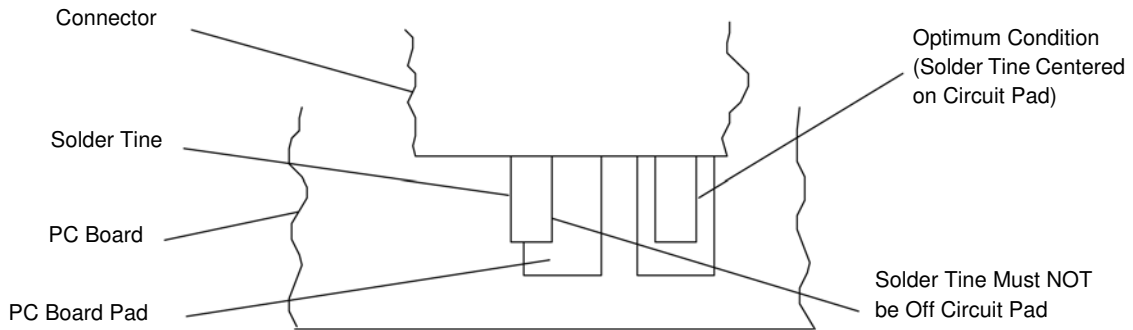

Figure 7

A. Soldering



Manual 402-40 provides some guidelines for establishing soldering practices.

1) Fluxing -- The contact solder tines and, if applicable, attaching hardware must be fluxed prior to soldering with a mildly active, rosin base flux. Selection of the flux will depend on the type of pc board and other components mounted on the board. Additionally, the flux must be compatible with the wave solder line, manufacturing, health, and safety requirements. Call the Product Information number at the bottom of page 1 for consideration of other types of flux. Some fluxes that are compatible with these connectors are provided in Figure 8.

FLUX TYPE	ACTIVITY	RESIDUE	COMMERCIAL DESIGNATION	
			KESTER	ALPHA
Type RMA (Mildly Activated)	Mild	Noncorrosive	185/197	611
Center (Activated)	Medium	May be Corrosive	1544, 1545, 1547	711, 809, 811

KESTER and ALPHA are trademarks.

Figure 8

2) Parameters -- The connectors will withstand temperatures of 230°C [446°F] for a maximum of three minutes. Higher temperatures can be withstood for short periods of time. However, the actual connector temperature should not exceed 250°C [482°F] for more than 15 seconds, with a maximum temperature of 255°C [491°F]. Refer to the recommendations provided in Figure 9 for typical infrared (IR) reflow oven settings. Due to the many variables involved with the reflow process (ie, component density, orientation, etc), we recommend that the user conduct trial runs under actual manufacturing conditions to ensure product and process compatibility.

PREHEAT 350°C [662°F]	ZONE 1	ZONE 2	ZONE 3
Top Heater	285°C [545°F]	265°C [509°F]	310°C [590°F]
Bottom Heater	285°C [545°F]	265°C [509°F]	310°C [590°F]

Figure 9

3) Techniques -- It is recommended that the connector be soldered using convection, vapor phase (VPR), double sided non-focused infrared (IR), or equivalent soldering technique provided the temperatures and exposure time are within the ranges specified in Figure 10. Higher temperatures can be withstood for short periods of time as indicated in Figure 9 for the IR reflow. TE recommends using a Corpane Batch Vapor Phase (Model VVP 10 BU) and Vitronics IR (Model SMD 718) equipment.

SOLDERING PROCESS	TEMPERATURE		TIME (At Max Temp)
	CELSIUS	FAHRENHEIT	
Vapor Phase Soldering	215	419	5 Minutes
Infrared Reflow Soldering	230	446	5 Minutes
Convection	230	446	5 Minutes

Figure 10

4) Reflow Parameters -- Due to the many variables involved with the reflow process (ie, component density, orientation, etc), we recommend that the user conduct trial runs under actual manufacturing conditions to ensure product and process compatibility.

B. Cleaning

After soldering, removal of fluxes, residues, and activators is necessary. Consult with the supplier of the solder paste and flux for recommended cleaning solvents. The following is a listing of common cleaning solvents that will not affect the connectors. The connectors will be unaffected by any of these solvents for 5 minutes at 105°C [221°F]. See Figure 11.

Cleaners must be free of dissolved flux and other contaminants. We recommend cleaning with the pc board on its edge. If using an aqueous cleaner, we recommend standard equipment such as a soak-tank or an automatic in-line machine



Even when using "no clean" solder paste, it is imperative that the contact interface be kept clean of flux and residue, since it acts as an insulator. Flux may migrate under certain conditions with elevated temperatures and, therefore, cleaning is necessary even with "no clean" paste.

CLEANER		TIME (Minutes)	TEMPERATURE (Maximum)
NAME	TYPE		
ALPHA 2110	Aqueous	1	132°C [270°F]
BIOACT EC-7	Solvent	5	100°C [212°F]
Butyl CARBITOL	Solvent	1	Ambient Room
Isopropyl Alcohol	Solvent	5	100°C [212°F]
KESTER 5778	Aqueous		
KESTER 5779	Aqueous		
LONCOTERGE 520	Aqueous		
LONCOTERGE 530	Aqueous		
Terpene	Solvent		

ALPHA, BIOACT, CARBITOL, LONCOTERGE, and KESTER are trademarks of their respective owners.

Figure 11



Consideration must be given to toxicity and other safety requirements recommended by the solvent manufacturer. Trichloroethylene and Methylene Chloride can be used with no harmful affect to the connectors; however, TE does not recommend them because of the harmful occupational and environmental effects. Both are carcinogenic (cancer-causing) and Trichloroethylene is harmful to the earth's ozone layer.



If you have a particular solvent that is not listed, contact the Product Information number at the bottom of page 1.

C. Drying

Air drying of cleaned connectors is recommended. Temperature for the connectors should not exceed -55 to 105°C [-67 to 221°F]. Degradation of the housings could result from extreme temperatures.

D. Checking Installed Connector

All solder joints should conform to those specified in Workmanship Specification 101-21. The housing must seat on the pc board to within the tolerance provided in Figure 12.

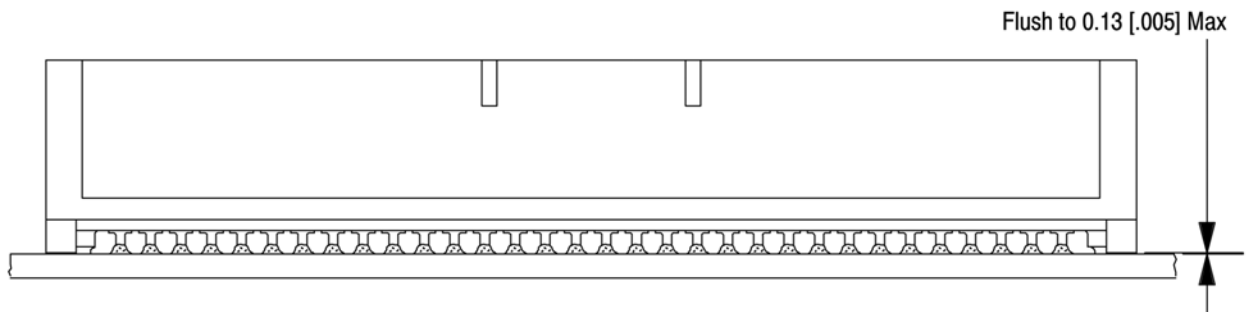

Figure 12

E. Mating/Unmating Connectors



The use of uneven or off-angle forces during mating and unmating of the connectors could cause overstress and damage to the contacts and/or housings. Using the "peel-back" method of unmating one end and pulling it until the other end is unmated is permissible. Do NOT use a severe side-to-side rocking motion to unmate connectors.

Connectors must be pushed straight in when mating and pulled straight out when unmating. A slight end-to-end motion may be used to start extraction, but it must not continue through full extraction cycle.

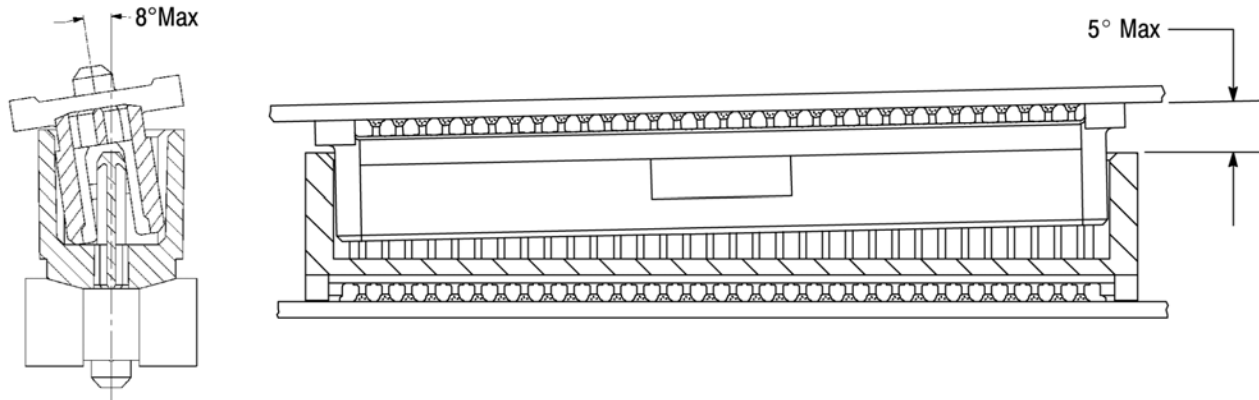

Figure 13



The angles of 5° and 8° in Figure 13 are specified as 3° and 1.5° respectively per EIA-700AAAB, and this should be considered if mating TE connectors with any other manufacturers' connectors.

Miniaturization is a design feature of these connectors and the systems in which they are used. Component density, connector location, and pc board size may make it difficult to remove the connector. Two methods are recommended to facilitate removal. If unmating board-to-board connectors, the preferred method is to have one of the pc boards securely fastened and adequately supported to withstand the pulling force applied to the other pc board. The second method is to construct a tool for your system design that will produce a straight-away separation of the connectors. See Figure 13.

3.8. Repair/Removal

Connectors may be removed from the pc board by standard de-soldering methods. Damaged connectors must be replaced.

4. QUALIFICATIONS

1.0 mm FH Plug and Receptacle Connectors are Listed by Underwriters Laboratories Inc. (UL) in File No. E28476 and Certified by CSA International in File No. LR7189A-319.

5. TOOLING

We recommend that you contact a reliable robotic equipment designer for assistance in developing equipment that meets your specific application requirements. The equipment must have a placement position accuracy tolerance of ± 0.05 mm [± 0.002 in.] to properly locate the connector for placement. This includes gripper and fixture tolerances as well as equipment repeatability. It must use the connector datum surfaces detailed on the Customer Drawing for the connector being used to ensure reliable placement of the connector.

The equipment feed mechanism must be compatible with the connector shipping containers. See shipping containers shown in Figure 14.

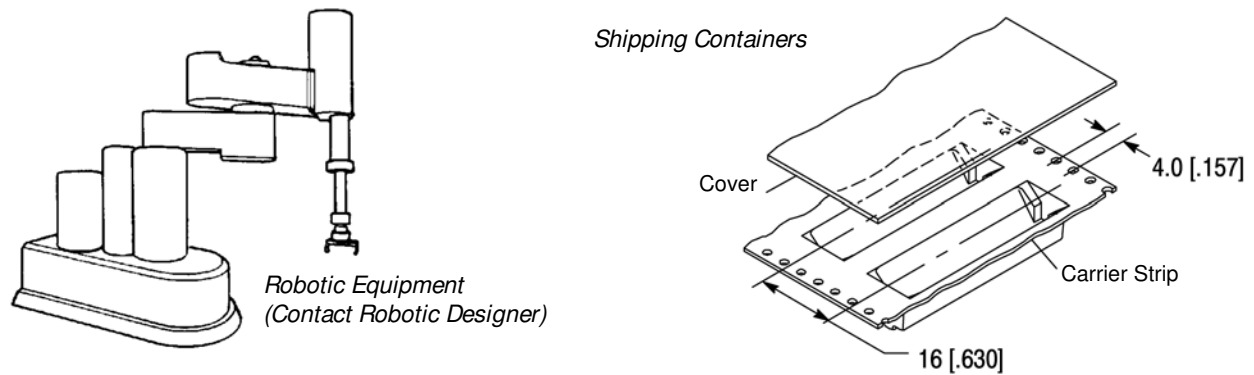

Figure 14

6. VISUAL AID

Figure 15 shows a typical application of 1.0 mm FH Plug and Receptacle Connectors. This illustration should be used by production personnel to visually ensure suitable applications. Installations which appear visually incorrect should be inspected using the dimensional information given in the preceding pages of this application specification.

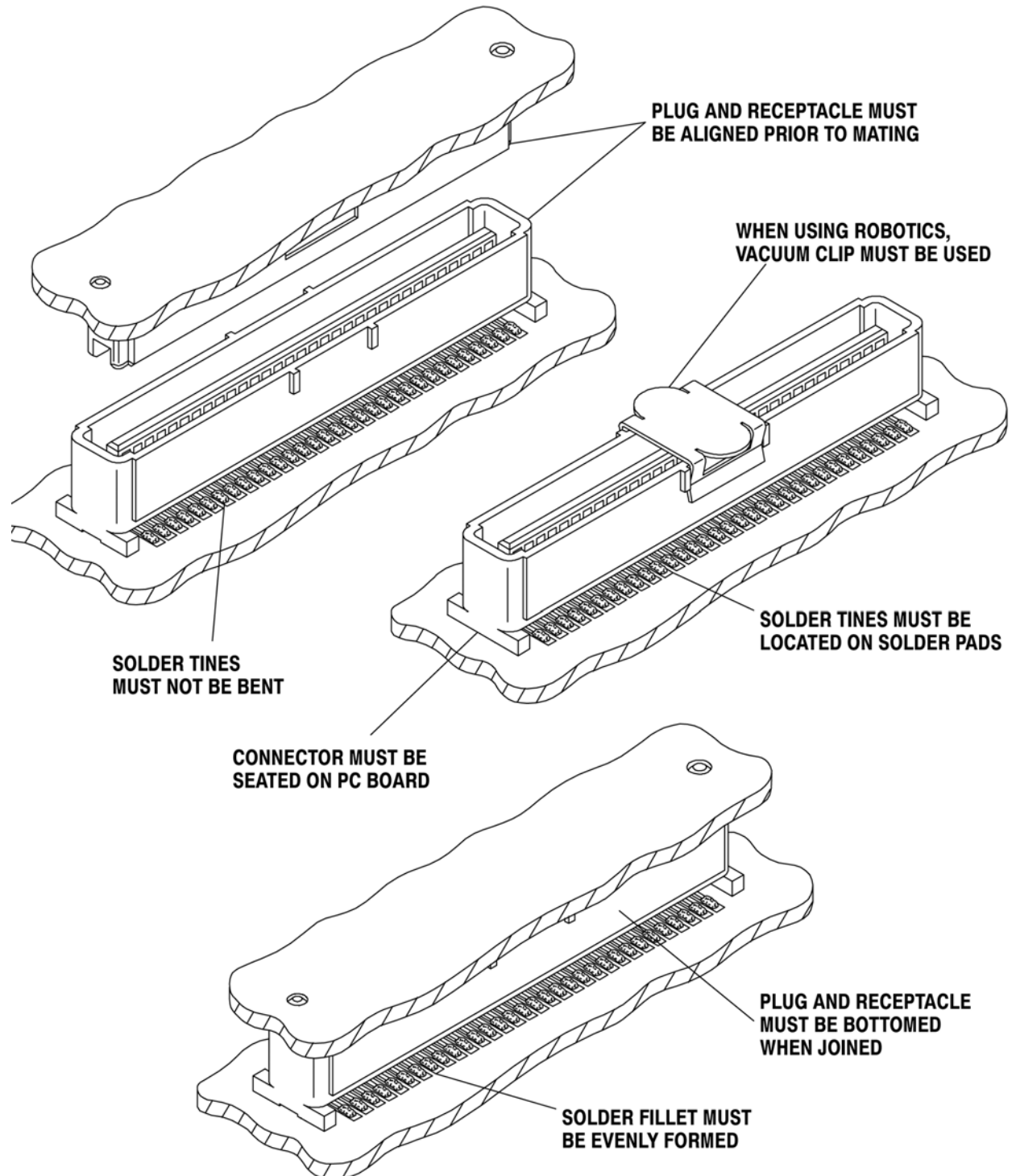

FIGURE 15. VISUAL AID