

CUI BASIC PRODUCT DATA DRAWING

REVISION HISTORY			
REV	DESCRIPTION	DATE	APPROVED
-	NRN 46243	09/21	SEE PDM

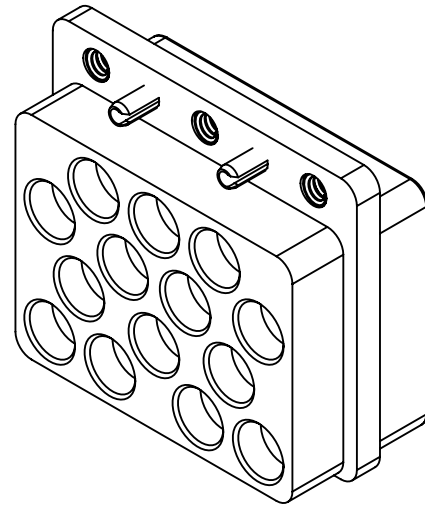

HOLE CHART		
HOLE No.	X	Y
ORIGIN	0.000	0.000
A1	0.423	0.217
A2	0.200	0.217
A3	-0.023	0.217
B1	0.584	0.365
B2	0.315	0.408
B3	0.085	0.408
B4	-0.184	0.365
C1	0.476	0.557
C2	0.200	0.600
C3	-0.076	0.557
D1	0.584	0.749
D2	0.362	0.749
D3	0.038	0.749
D4	-0.184	0.749

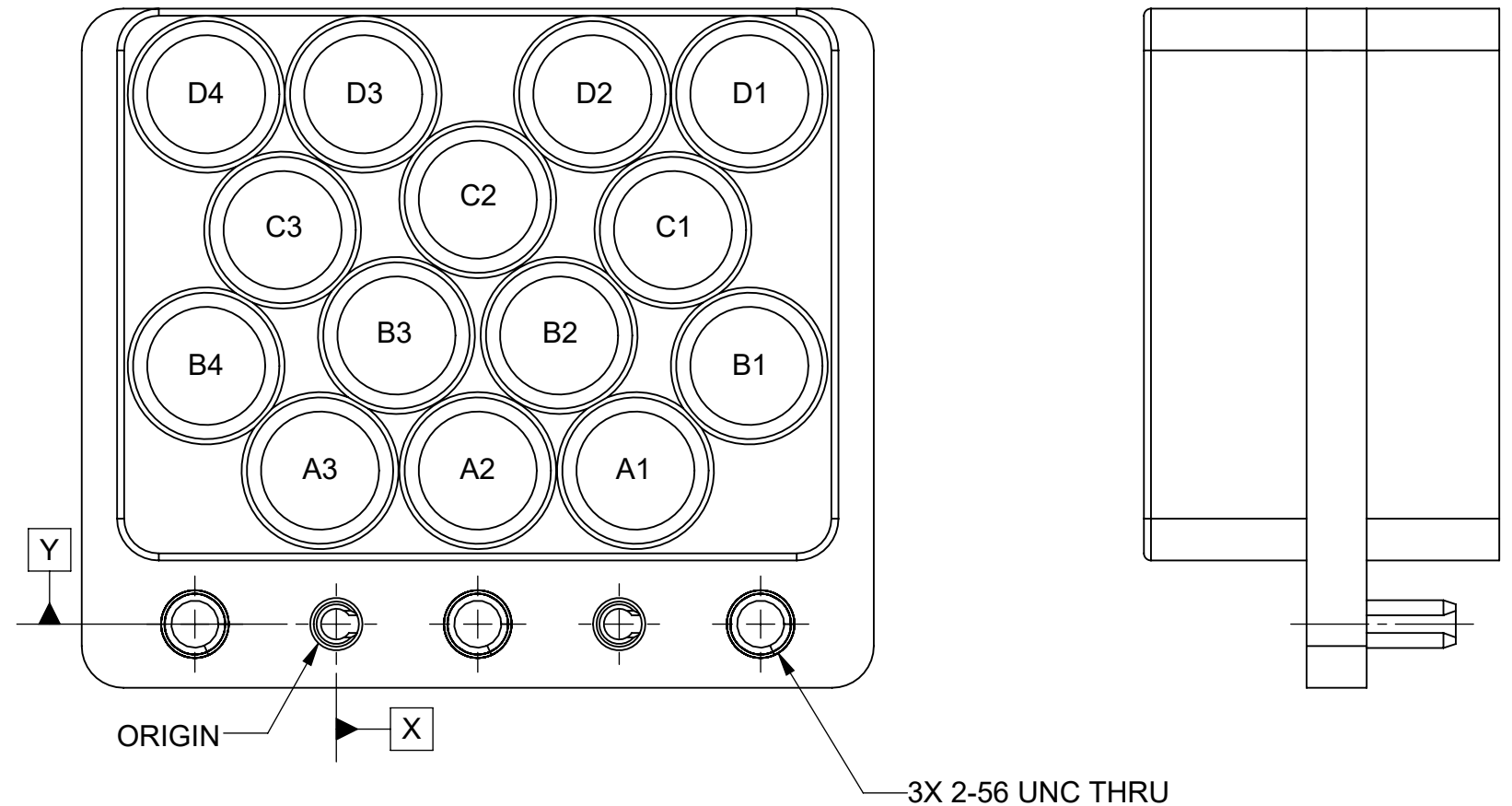

MATERIAL:

BODY: ALUMINUM ALLOY 7075
 ALIGNMENT PINS: STAINLESS STEEL PER ASTM A313, ALLOY UNS S30200, TYPE 302
 THREADED INSERTS: 18-8 STAINLESS STEEL
FINISH:
 ALIGNMENT PINS: PASSIVATED PER AMS-2700

NOTES:

1. USES 3221-40066 CONTACT OR SIMILAR.
2. MATES TO SF9301-60042, SF9311-60147, 9311-60221, OR 9311-80024 PLUG-IN MODULE.

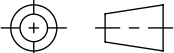
MATERIAL: SEE NOTES	DIMENSIONS ARE IN INCHES TOLERANCES: FRACTIONAL: $\pm 1/64$ ANGULAR: X° $\pm 1'0''$ X°X' $\pm 15''$	UNLESS OTHERWISE SPECIFIED 1) ALL DIMENSIONS ARE IN INCHES (MILLIMETERS) 2) ALL DIMENSIONS ARE AFTER PLATING. 3) BREAK CORNERS & EDGES .005 R. MAX. 4) CHAM. 1ST & LAST THREADS. 5) SURFACE ROUGHNESS 63-MIL-STD-10. 6) DIA: 'S ON COMMON CENTERS TO BE CONCENTRIC WITHIN .005 T.I.R. 7) REMOVE ALL BURRS	 TITLE: VITA 67.3 BACKPLANE MODULE C 14 PORT, SMPM
FINISH: SEE NOTES	DECIMAL: X $\pm .030$.XX $\pm .010$.XXX $\pm .005$	INTERPRET DIMENSIONS AND TOLERANCES PER ASME Y14.5M - 1994	DWG. NO. 9321-80035 SCALE: 4:1
SURFACE AREA: N/A	THIRD ANGLE PROJECTION	DRAWN: JPM 09/02/21 CHECKED: SEE PDM APPROVED: SEE PDM	SHEET 1 OF 2
PROPRIETARY THE INFORMATION CONTAINED IN THIS DRAWING IS THE SOLE PROPERTY OF SV MICROWAVE, INC. ANY REPRODUCTION IN PART OR AS A WHOLE WITHOUT THE WRITTEN PERMISSION OF SV MICROWAVE, INC IS PROHIBITED.			

CUI BASIC PRODUCT DATA DRAWING

REVISION HISTORY			
REV	DESCRIPTION	DATE	APPROVED
-	NRN XXXXX	00/00	SEE PDM

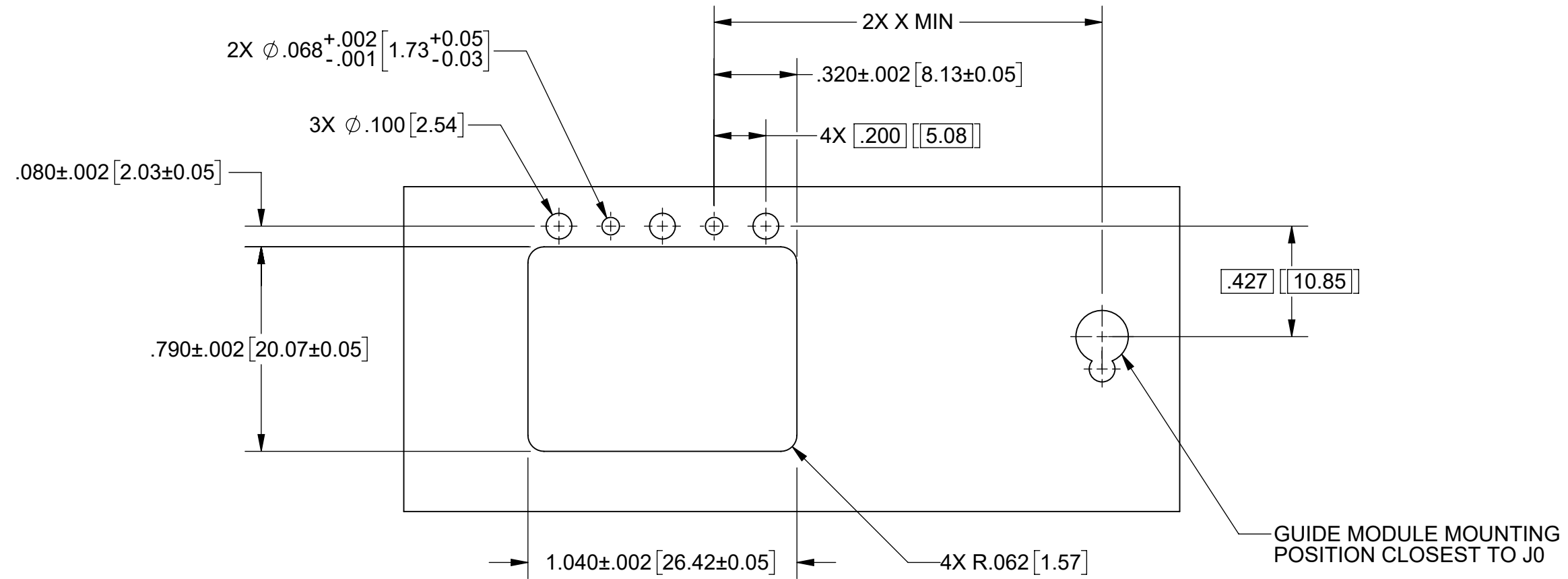

RECOMMENDED PCB CUTOUT

CONNECTOR LOCATION ON BACKPLANE PCB	
POSITION	DIM 'X'
J2	2.385" [60.58]
J3	3.942" [100.13]
J4	5.276" [134.00]
J5	6.409" [162.80]
J6	7.557" [191.95]

MATERIAL:	SEE NOTES	DIMENSIONS ARE IN INCHES TOLERANCES:	UNLESS OTHERWISE SPECIFIED	 www.svmicrowave.com
FINISH:	SEE NOTES	FRACTIONAL: $\pm 1/64$ ANGULAR: X° $\pm 1'0"$ X'X' $\pm 15'$	1) ALL DIMENSIONS ARE IN INCHES (MILLIMETERS) 2) ALL DIMENSIONS ARE AFTER PLATING. 3) BREAK CORNERS & EDGES .005 R. MAX. 4) CHAM. 1ST & LAST THREADS. 5) SURFACE ROUGHNESS 63-MIL-STD-10. 6) DIA: 'S ON COMMON CENTERS TO BE CONCENTRIC WITHIN .004 T.I.R. 7) REMOVE ALL BURRS	TITLE:
SURFACE AREA:	N/A	DECIMAL: X $\pm .030$.XX $\pm .010$.XXX $\pm .005$	INTERPRET DIMENSIONS AND TOLERANCES PER ASME Y14.5M - 1994	VITA 67.3 BACKPLANE MODULE C 14 PORT, SMPM
PROPRIETARY		THIRD ANGLE PROJECTION		SIZE DWG. NO.
THE INFORMATION CONTAINED IN THIS DRAWING IS THE SOLE PROPERTY OF SV MICROWAVE, INC. ANY REPRODUCTION IN PART OR AS A WHOLE WITHOUT THE WRITTEN PERMISSION OF SV MICROWAVE, INC IS PROHIBITED.				B 9321-80035
		DRAWN: JPM 09/02/21	CHECKED: SEE PDM	SCALE: 4:1
		APPROVED: SEE PDM		SHEET 2 OF 2