

STRAIGHT BULKHEAD JACK CLAMP TYPE

R112.305.000

REAR MOUNT - CABLE 2.6/50+75 S

Series : SMC

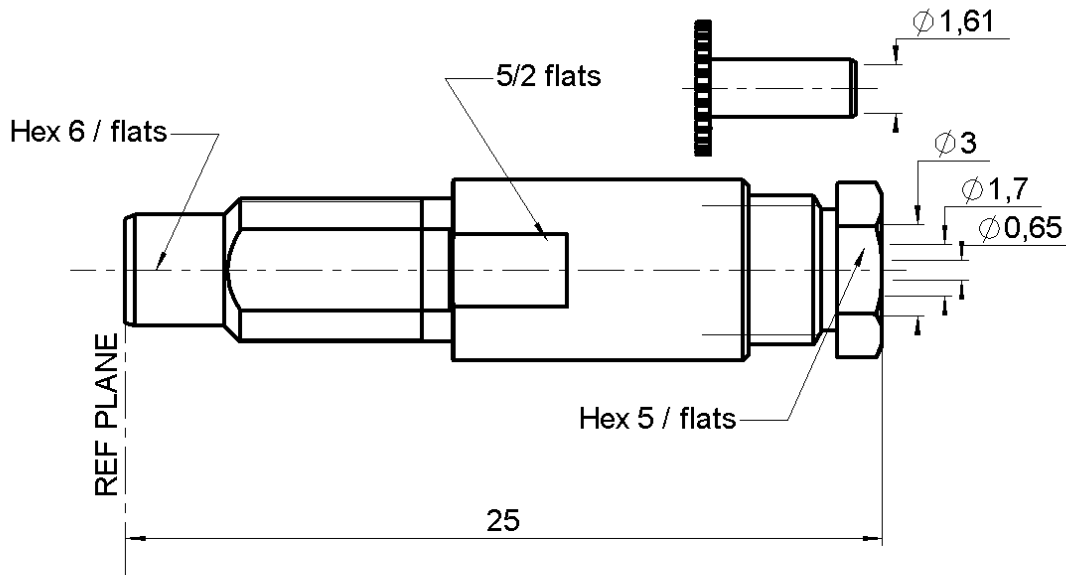

PANEL CUT OUT

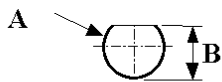

	mm	
	Maxi	mini
A	5	4.9
B	4.58	4.46

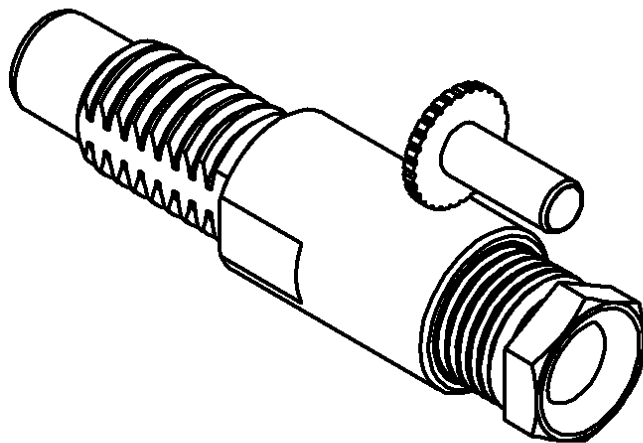
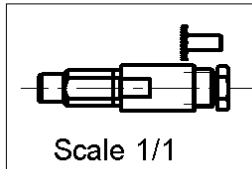

All dimensions are in mm.



COMPONENTS	MATERIALS	PLATINGS (µm)
BODY	BRASS	GOLD 0.2 OVER NICKEL 2
CENTER CONTACT	BRASS	GOLD 1.3 OVER NICKEL 2
OUTER CONTACT	-	-
INSULATOR	PTFE	-
GASKET	CHLOROPRENE	-
OTHERS PARTS	BRASS	GOLD 0.2 OVER NICKEL 2
-	-	-
-	-	-

Issue : 0341 E

In the effort to improve our products, we reserve the right to make changes judged to be necessary.



STRAIGHT BULKHEAD JACK CLAMP TYPE

R112.305.000

REAR MOUNT - CABLE 2.6/50+75 S

Series : SMC

PACKAGING

Standard	Unit	Other
1	-	Contact us

SPECIFICATION

CABLE ASSEMBLY

ELECTRICAL CHARACTERISTICS

Stripping	a	b	c	d	e	f
mm	2.50	1.20	4.50	4.50	0.00	0.00

Impedance		50 Ω
Frequency		0-10 GHz
VSWR	1.20 +	0.040 x F(GHz) Maxi
Insertion loss		0.125 √F(GHz) dB Maxi
RF leakage	- (62 - F(GHz)) dB mini
Voltage rating		335 Veff Maxi
Dielectric withstanding voltage		1000 Veff mini
Insulation resistance		1000 MΩ mini

Assembly instruction :

Recommended cable(s)

RG 187
RG 188
RG 316
RG 179
KX 22A

MECHANICAL CHARACTERISTICS

Cable retention

- pull off **110** N mini
- torque **NA** N.cm

Center contact retention		
Axial force – Mating end		10 N mini
Axial force – Opposite end		10 N mini
Torque		NA N.cm mini

TOOLING

Part Number	Description	Hexagon
.	.	.

Recommended torque		
Mating		NA N.cm
Panel nut		60 N.cm
Clamp nut		70 N.cm
A/F clamp nut		5.000 mm

OTHERS CHARACTERISTICS

Mating life		500 Cycles mini
Weight		3.000 g

ENVIRONMENTAL

Operating temperature		-65/+165 °C
Hermetic seal		NA Atm.cm3/s
Panel leakage		NA

Issue : 0341 E

In the effort to improve our products, we reserve the right to make changes judged to be necessary.



STRAIGHT BULKHEAD JACK CLAMP TYPE

R112.305.000

REAR MOUNT - CABLE 2.6/50+75 S

Series : SMC

COMPONENTS

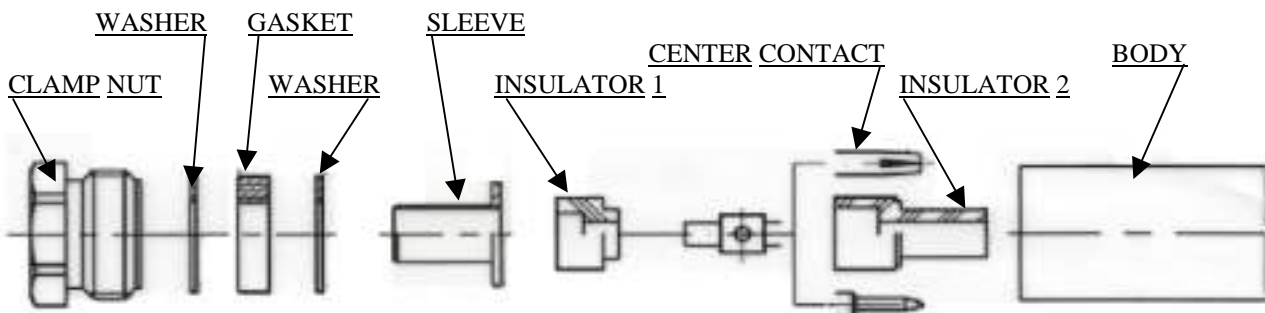

1

- Mount clamp nut, washer, flat gasket, washer.
- Strip the cable, make 2 slits 180° apart in the sheath.

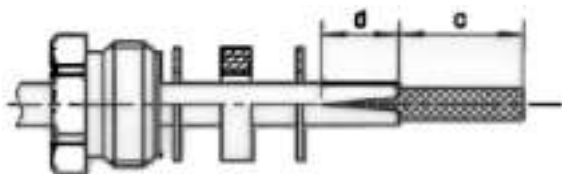

3

- Mount the insulator 1
- Mount the center contact and solder.
- Mount the insulator.2

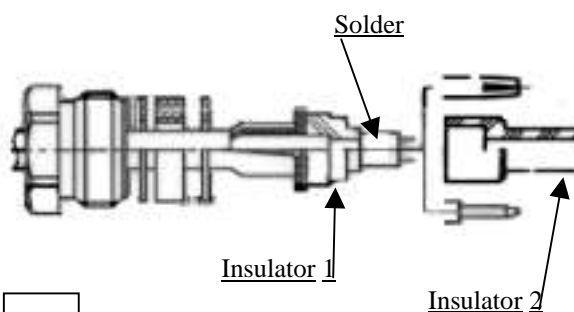

2

- Mount the braid-clamp. (for cable 2.6/50 use knurled clamp , for cable 2.6/75 use smooth clamp.
- Cut braid flush Ø of braid clamp.
- Strip off the dielectric.

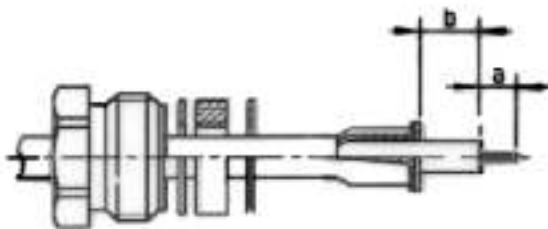

4

- Screw the cable assembly into the body.
- Recommended coupling (see connector TDS)

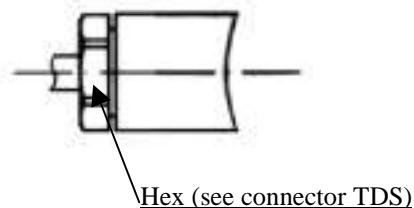

Issue : 0341 E

In the effort to improve our products, we reserve the right to make changes judged to be necessary.

