

S286-V05 Oil Level Switch

Document ref.: DDS_S286-V05

25-Jan-21

Rev. 1

The S286 is an active device designed to give an alarm signal if liquid falls below, or rises above, a preset level. It can be specified with a delay to eliminate false alarms due to turbulence. Containing a factory programmable microprocessor, the switch offers sink to ground or source voltage output. For high accuracy the S286 is ideally mounted horizontally at the point where an alarm or control signal is required.

| | |
|--------------------|---|
| Part | S286-V05 |
| Description | 1/2" NPTF, PU 1 LIQ, SS 10 FA, SI LIQ, SO AIR |
| Prod. Group | Oil Level Switch |
| Technology | Capacitance |
| Liquid | Mineral Oil |
| Output Type | Sink & Source |
| Connector | Metri-pack 150 - 4 Pins |
| Thread | 1/2" NPTF |

Performance

| | |
|--------------|-------------------------------|
| Output | Sink in Liquid, Source in Air |
| Alarm Delay | 10 s (Factory Set) |
| Power Up | in Liquid |
| Switch Sense | Level Falling |

Materials

| | |
|-------------|------------------------|
| Body | Brass |
| Probe | PTFE |
| Terminals | Brass, Tin Plated |
| Seals | EDPM, FVMQ |
| Connector | 30% Glass Filled Nylon |
| Thread Seal | Vibra-Seal 516 |

Ratings

| | |
|-------------|----------------|
| Sealing | IP67 |
| Pressure | 5 Bar (max) |
| Drop | 1M to concrete |
| Vibration | 15.3 Grms |
| Temperature | -40 to +125 C |
| EMC | ISO13766:2006 |

Electricals

| | |
|----------------|----------------------|
| Supply Voltage | 9-36 VDC |
| Supply Current | 7 mA + source output |

Harness Information

| | |
|---------------------|------------|
| Connector | M/P 150-4P |
| Source Output | Pin A |
| Sink Output | Pin D |
| +ve supply location | Pin C |
| Ground | Pin B |

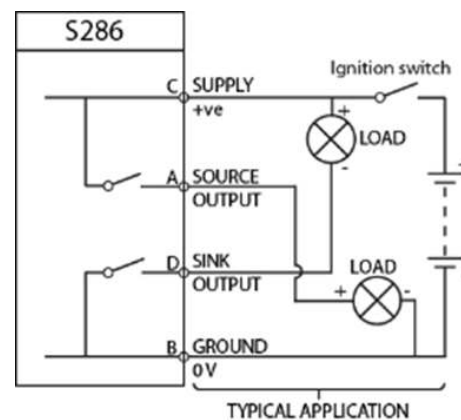
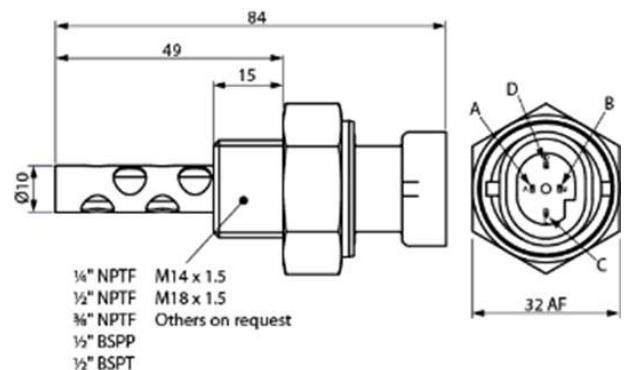

NOTE: IF SINK ONLY OUTPUT IS REQUIRED THEN PIN A IS NOT USED.