

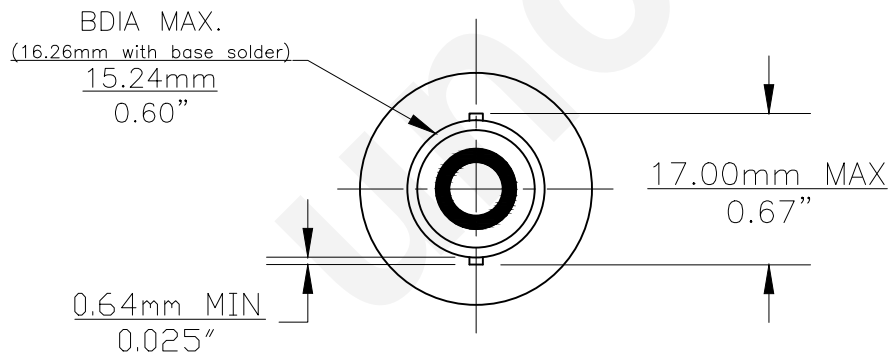

PART NO.	BASE TYPE	DESIGN VOLTS	DESIGN AMPS	MSCD	FILAMENT TYPE	AVERAGE LIFE HOURS	REVISIONS			
							REV #	DESCRIPTION	DATE	APPROVED
1141LL	S.C. Bayonet (BA15s)	12.8V	1.44±5%	21±10%	C-6	2000	1	ISSUED	05/30/2013	R.M.

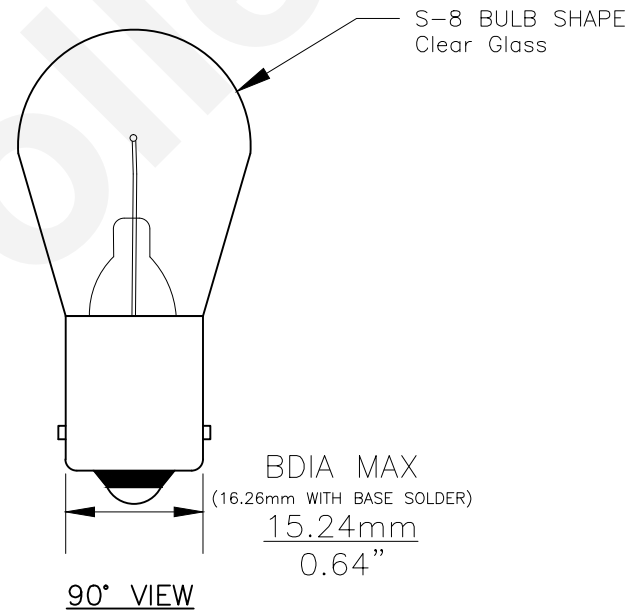

Note: Made according to SAE specifications

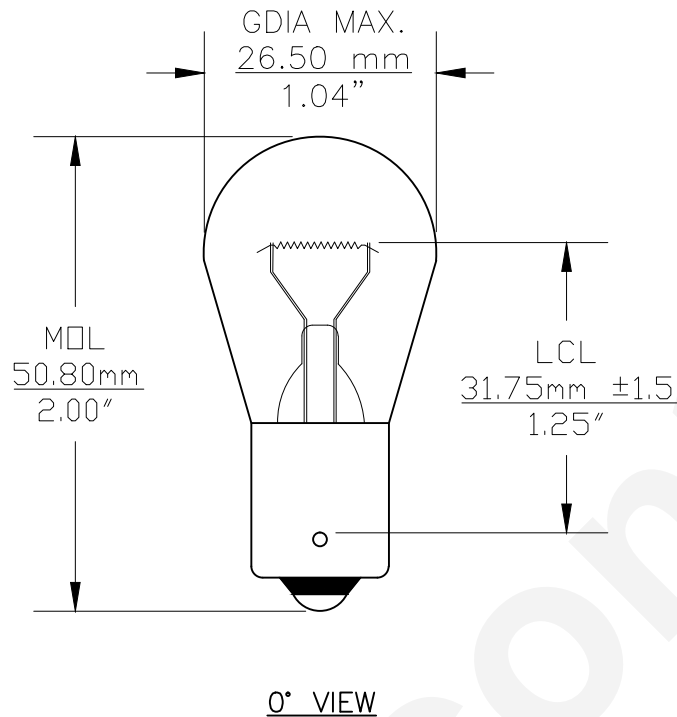

UNLESS OTHERWISE SPECIFIED: DIMENSIONS ARE IN INCHES TOLERANCES		CEC INDUSTRIES LTD			
DECIMALS	ANGULAR	599 BOND STREET		LINCOLNSHIRE, IL 60069	
.XX ± .05	± 0.5°	TITLE LIGHT BULB NO. 1141LL			
.XXX ± .010		SIZE A	FSCM NO.	DWG NO. 1141LL	REV 1
FRACTIONAL	±1/64	SCALE	PLOT SCALE	SHEET 1 OF 1	
DRAWN D.C.		DATE 05/30/2013	MATERIAL		
CHECKED		FILE 1141LL.pdf	DRAWING NOT TO SCALE		