

APPROVED: _____
 DATE: _____ TITLE: _____

Rev	AWO #	Description	Date	Appr
-		RELEASED	7/30/15	
A		UPDATE DRAWING	3/18/20	LH/MY

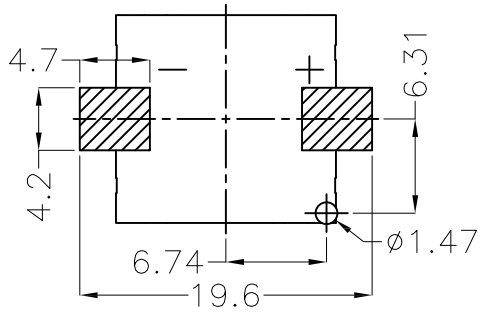

RECOMMENDED PCB LAYOUT

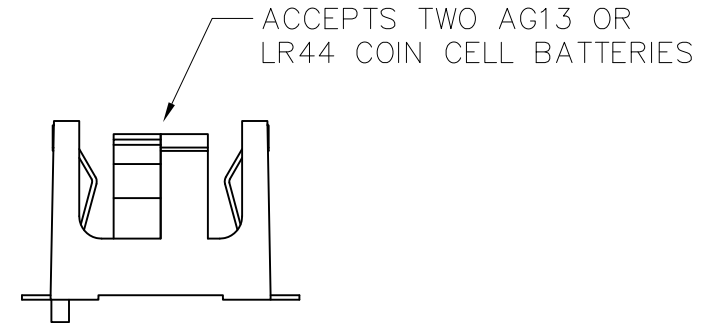
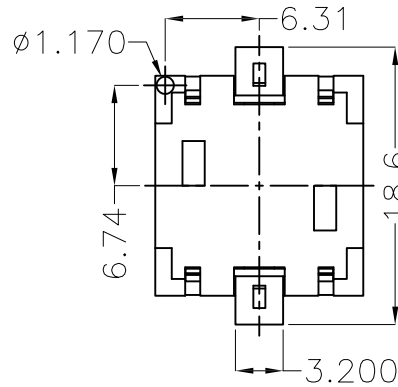
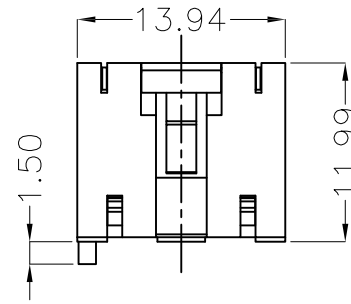
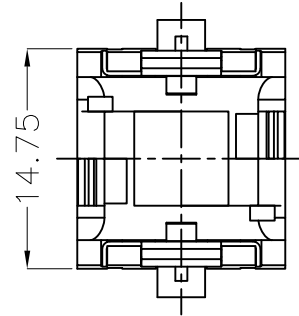

PART NO.	MATERIAL
BH-82-5-1A	PBT, BLACK
BH-82-5-1B	PA66, BLACK
BH-82-5-2A	PPA, BROWN
BH-82-5-2B	PPA, BLACK
BH-82-5-3A	PPS, BROWN
BH-82-5-3B	PPS, BLACK
BH-82-5-4A	LCP, WHITE
BH-82-5-4B	LCP, BLACK

SPECIFICATIONS:

Material:
 Housing: (See chart)
 Housing Color: (See chart)
 Contact: Phosphor Bronze, Gold Plated
 Electrical:
 Contact resistance: 30 Milliohms max
 Insulation resistance: 1,000 Megaohms ohms min
 Dielectric Voltage: 500 VAC one sec level
 Temperature Rating:
 Operating temperature: -25°C to +85°C.
 Environmental:
 Lead free, RoHS compliant



UNLESS OTHERWISE SPECIFIED
 ALL DIMENSIONS ARE MILLIMETERS
 TOLERANCES: EXCEPT AS NOTED
 MM ANGLE
 X ± 0.30 X ± 1°
 X.X ± 0.25 X.X ± 0.5°
 X.XX ± 0.20
 X.XXX ± 0.10

ADAM TECH INTERCONNECTS
 909 Rahway Avenue,
 Union, NJ 07083
 Phone: 908-687-5000
 Fax: 908-687-5710

APPROVALS		DATE
DRAWN	HR	8/17/15
CHECKED	NC	8/17/15
APPROVED		

TITLE BATTERY HOLDER, SMT TYPE, FOR TWO AG13 / LR44 COIN CELL			
SIZE X	PART NO. BH-82-5-XX	REV. A	
REF: S00138C	SCALE: NTS	SHEET 1 OF 1	