

REVISION			
REV.	DESCRIPTION	DATE	APPROVED

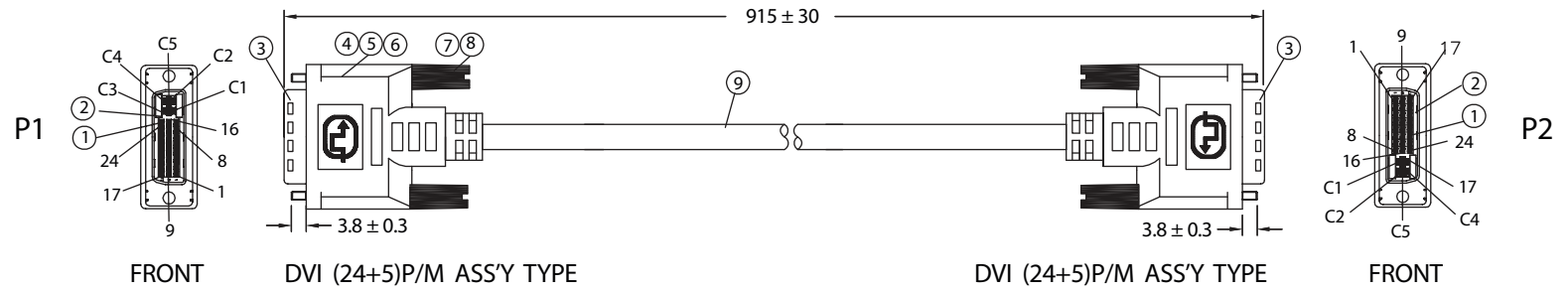

PIN OUT

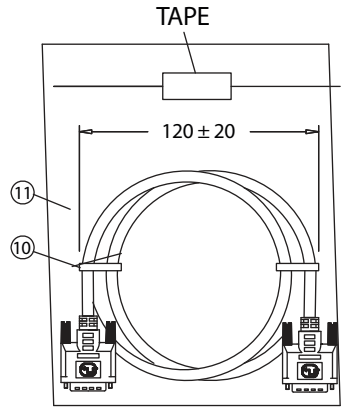
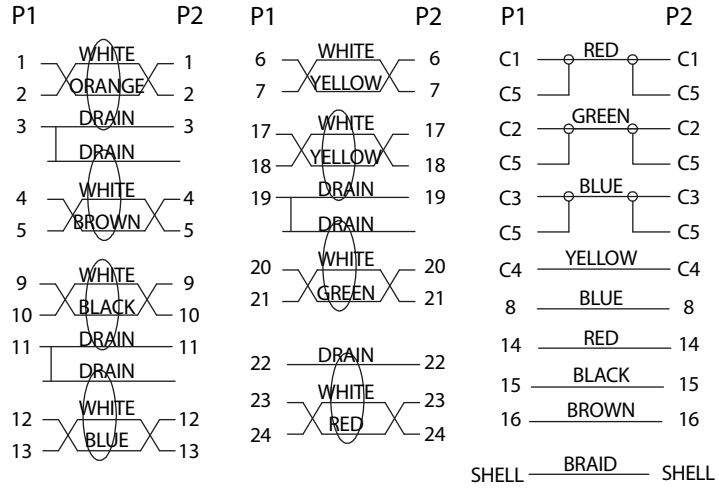

No.	PARTS NAME	SPECIFICATION STANDARD	QTY	REMARKS
①	DVI (24+5)P/M - CONTACT	BRONZE/GOLD PLATED SOLDER TYPE	58	
②	DVI (24+5)P/M - INSULATOR	THERMOPLASTIC/BLACK UL94V-0	2	
③	DVI (24+5)P/M - SHELL	NICKEL PLATED	2	
④	DVI (24+5)P/M - CAN	STEEL TIN PLATED	2	
⑤	COPPER FOIL	WIDTH: 15mm	2	
⑥	DVI (24+5)P/M - COVER	45P PVC/COLOR: BEIGE	2	
⑦	THUMB SCREW	#4-40 2.8x45, NICKEL PLATED	4	
⑧	SCREW - MOLD	35P PVC / COLOR: BLACK	4	
⑨	CABLE DVI 24+5 UL20276	KL03009ABK01A	1	
⑩	MINI TIE	PE/BLACK	2	
⑪	POLYBAG	PE/0.08x160x200mm	1	

- NOTES:
- CABLE: UL20276
 [(28AWGx1P+DW+FOIL)x7+(28AWG+SP+FOIL)x3+28AWGx5C+28AWGx1P+MYLAR+FOIL+BD]x1
 OUTER JACKET: BIEGE, OD: 9.5 ± 0.3mm
 PRINTING: "E166307 AWM 20276 28AWG 80°C 30V VW-1
 LOW VOLTAGE COMPUTER CABLE
 - CONNECTORS: DVI (24+5)P/M - DVI (24-5)P/M
 - HOOD: ASS'Y TYPE. COLOR: BEIGE
 - CABLE ELECTRICAL TEST:
 <1>.100% OPEN SHORT & MISS WIRE TEST
 <2>.INSULATION RESISTANCE: DC400V 10M ohm MIN.
 <3>.CONDUCTOR RESISTANCE: 3 ohm MAX.
 - PACKING: 1PC/POLYBAG

Dim range (mm)	Tolerance +/- (mm)	Qualtek Electronics Corp. WCI DIVISION		
		Part Number: 1321010-03		RoHS Compliant
0-1	0.15	Description: DVI (24+5)P/M - DVI (24+5)P/M		
1-6	0.20			
6-18	0.30			
18-50	0.50			
50-120	0.70	Drawn / Date	Checked / Date	Approved / Date
120-250	0.90	B.Grubb 01-12-07	01-12-07	JJH / 01-12-07
250-500	1.20			