

NOTES:

- 1) CONNECTOR MATERIALS:
HOUSING IS MADE OF NYLON (SEE CHART ON SHEET 2 FOR COLOR) AND ACTUATOR IS MADE OF LCP [LIQUID CRYSTAL POLYMER] (COLOR IS BLUE), BOTH ARE GLASS-FILLED AND RATED U.L. 94V-0; TERMINALS ARE 0.32/(.013) THICK PHOSPHOR BRONZE.
- 2) TERMINAL FINISH:
5.0 MICROMETERS/200 MICROINCHES MINIMUM TIN OVER 1.3 MICROMETERS/ 50 MICROINCHES MINIMUM NICKEL UNDERPLATE OVERALL.
- 3) THIS CONNECTOR CONFORMS TO PRODUCT SPECIFICATION PS-71226.
- 4) SEE SHEET 2 FOR CONNECTOR PART NUMBERS, PACKAGING OPTIONS, AND DIMENSIONS NOT SHOWN BELOW.

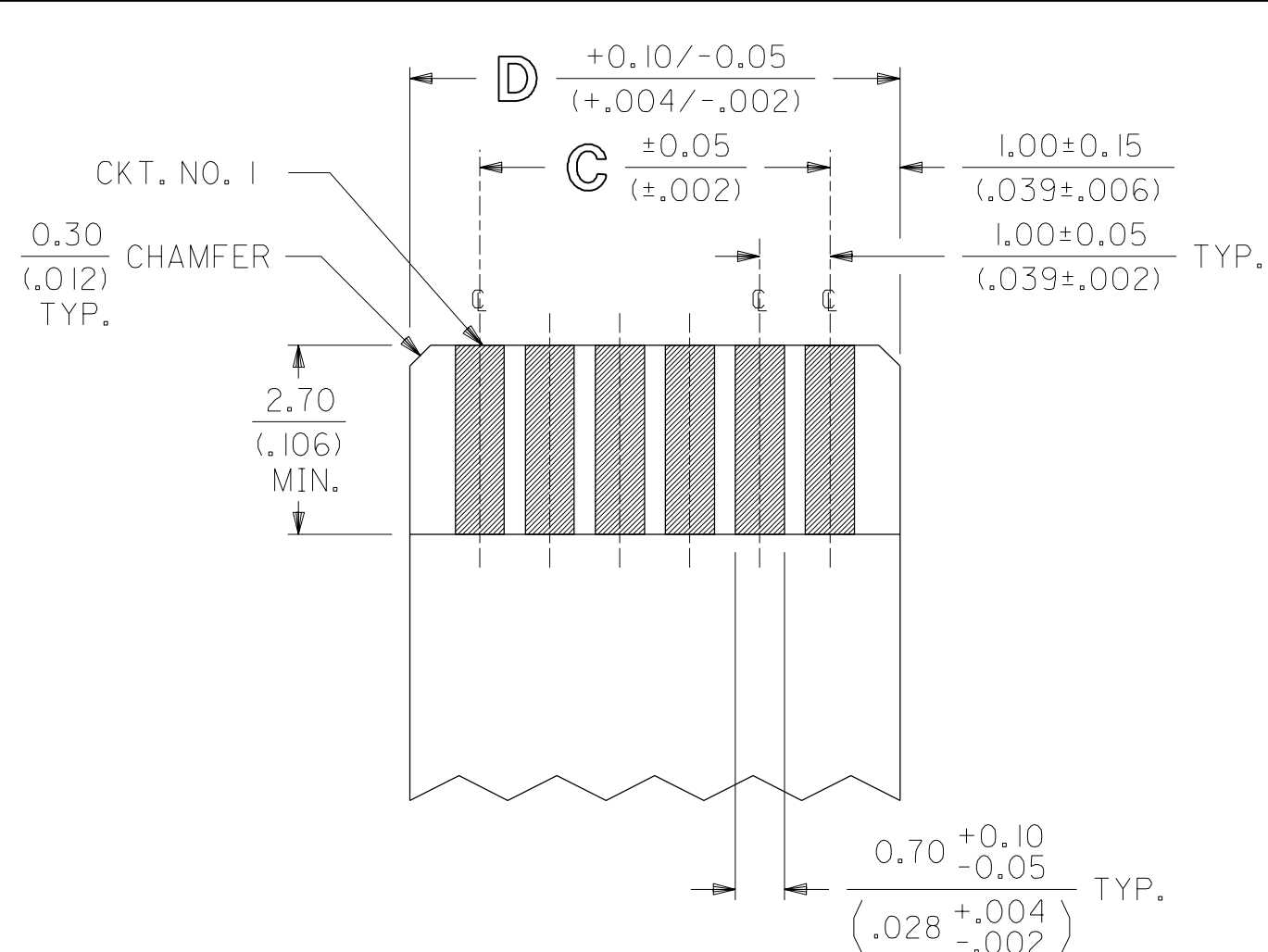

RECOMMENDED FFC DIMENSIONS
FINISHED THICKNESS = 0.30±0.05/(.012±.002)

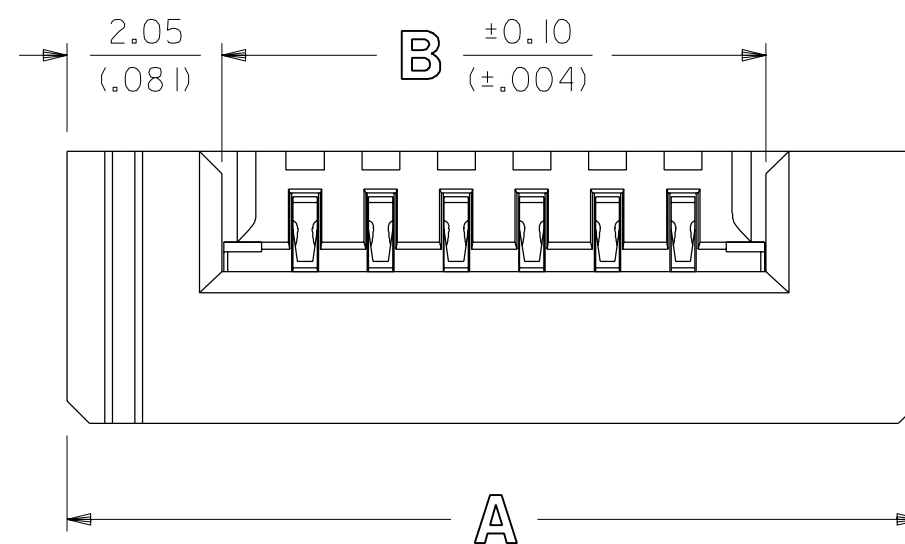
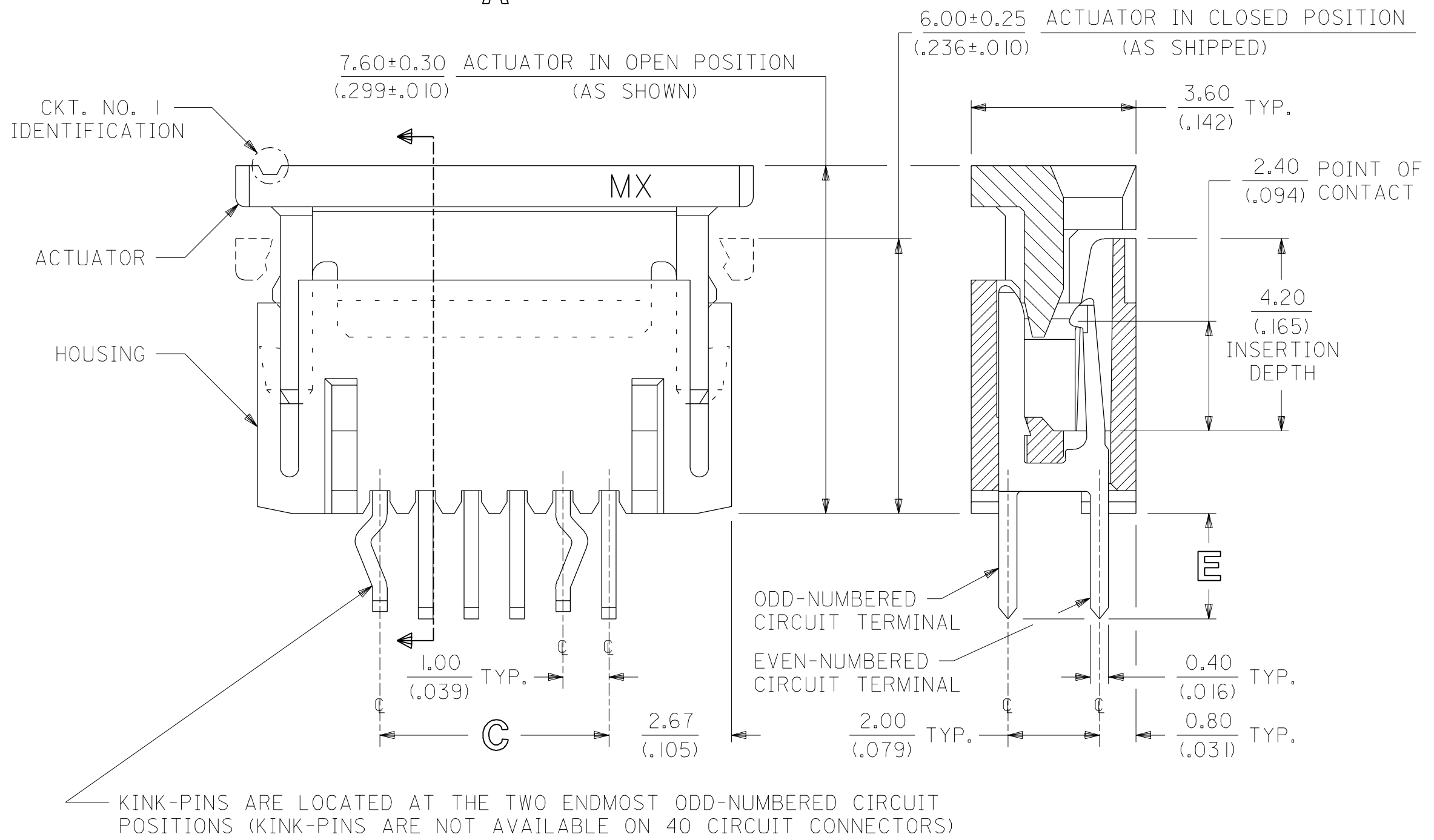

KINK-PINS ARE LOCATED AT THE TWO ENDMOST ODD-NUMBERED CIRCUIT POSITIONS (KINK-PINS ARE NOT AVAILABLE ON 40 CIRCUIT CONNECTORS)

NOTE FOR LEAD FREE CONVERSION:
THE PRIMARY SHIPPING CARTON WILL BE LABELED "COMPLIANT TO RoHS DIRECTIVE 2002/95/EC AND ELV ANNEX II OF DIRECTIVE 2000/53/EC". CARTONS WITHOUT THIS LABEL MAY CONTAIN PRODUCT WITH LEAD.

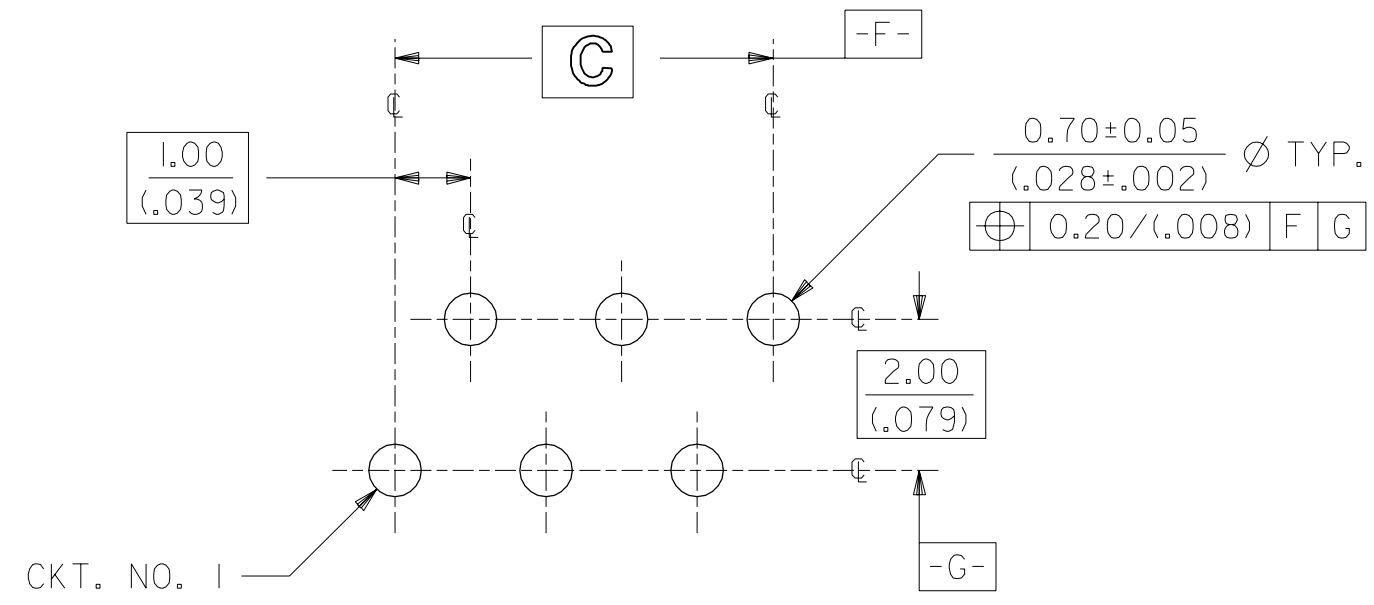

RECOMMENDED PC BOARD LAYOUT
COMPONENT SIDE IS SHOWN

DIMENSIONS SHOWN METRIC/(INCHES)

F		DELETE TUBE PKG UCP2003-1972 RWHITE 03/03/17	C2	ADD CKT. NO. 1 ECN #UDT1999-0014 07/08/98 LMCGRATH	UNLESS OTHERWISE SPECIFIED TOLERANCES: ANGULAR ± 1/2° 3 PLACE ± .005 2 PLACE ± — ± 0.13 1 PLACE — ± — DRAFT WHERE APPLICABLE MUST REMAIN WITHIN DIMENSIONS	▽ = 0 ▼ = 0 REVISE ONLY ON CAD SYSTEM	TITLE 1.00mm/(.039) PITCH, ZIF, FFC CONNECTOR	
E		MOD HSG GEOMETRY ECN# UDT1999-1104 DMORGAN 99/07/09	C1	ADD PKG SPEC ECN #UDT1998-0299 05/26/98 LMCGRATH			MOLEX INCORPORATED LITSL.E,ILL. 60532 U.S.A.	
G		LEAD FREE CONV ECN UCP2004-2092 RKADAMS 04/04/22	D	ADD P/N -2675 ECN #UDT1999-0824 DMORGAN 99/04/06	C	ADDED TOL. & BASIC BOXES PER EC # U81224 J. LONG 97/11/20	PART NO. SD7122607 DGN	
LTR.		REVISIONS	LTR.	REVISIONS	LTR.	REVISIONS	DRAWG. NO. SD-71226-***5	
LTR.		REVISIONS	LTR.	REVISIONS	LTR.	REVISIONS	DIV. SIZE CPP C	

2	F
1	G
MFG.	SH.
	REV.

13 12 11 10 9 8 7 6 71226 4 3 2 1

CKT SIZE	ITEM NUMBER	HOUSING COLOR	X=NOT TOOLED	DIM A	DIM B	DIM C	DIM D	DIM E
4	71226-0425	NATURAL		9.30/(.366)	5.20/(.205)	3.00/(.118)	5.00/(.197)	↑ 2.25±0.20 (.089±.008) ↓
6	71226-0625	NATURAL		11.30/(.445)	7.20/(.283)	5.00/(.197)	7.00/(.276)	
8	71226-0825	NATURAL		13.30/(.524)	9.20/(.362)	7.00/(.276)	9.00/(.354)	
10	71226-1025	NATURAL		15.30/(.602)	11.20/(.441)	9.00/(.354)	11.00/(.433)	
12	71226-1225	NATURAL		17.30/(.681)	13.20/(.520)	11.00/(.433)	13.00/(.512)	
14	71226-1425	NATURAL		19.30/(.760)	15.20/(.598)	13.00/(.512)	15.00/(.591)	
16	71226-1625	NATURAL		21.30/(.839)	17.20/(.677)	15.00/(.591)	17.00/(.669)	
18	71226-1825	NATURAL		23.30/(.917)	19.20/(.756)	17.00/(.669)	19.00/(.748)	
20	71226-2025	NATURAL		25.30/(.996)	21.20/(.835)	19.00/(.748)	21.00/(.827)	
22	71226-2225	NATURAL		27.30/(1.075)	23.20/(.913)	21.00/(.827)	23.00/(.906)	
24	71226-2425	NATURAL		29.30/(1.154)	25.20/(.992)	23.00/(.906)	25.00/(.984)	
26	71226-2625	NATURAL		31.30/(1.232)	27.20/(1.071)	25.00/(.984)	27.00/(1.063)	
28	71226-2825	NATURAL		33.30/(1.311)	29.20/(1.150)	27.00/(1.063)	29.00/(1.142)	
30	71226-3025	NATURAL		35.30/(1.390)	31.20/(1.228)	29.00/(1.142)	31.00/(1.220)	
40	71226-4025	NATURAL	X	45.30/(1.783)	41.20/(1.622)	39.00/(1.536)	41.00/(1.614)	
4	71226-0435	NATURAL		9.30/(.366)	5.20/(.205)	3.00/(.118)	5.00/(.197)	
6	71226-0635	NATURAL		11.30/(.445)	7.20/(.283)	5.00/(.197)	7.00/(.276)	
8	71226-0835	NATURAL		13.30/(.524)	9.20/(.362)	7.00/(.276)	9.00/(.354)	
10	71226-1035	NATURAL		15.30/(.602)	11.20/(.441)	9.00/(.354)	11.00/(.433)	
12	71226-1235	NATURAL		17.30/(.681)	13.20/(.520)	11.00/(.433)	13.00/(.512)	
14	71226-1435	NATURAL		19.30/(.760)	15.20/(.598)	13.00/(.512)	15.00/(.591)	
16	71226-1635	NATURAL		21.30/(.839)	17.20/(.677)	15.00/(.591)	17.00/(.669)	
18	71226-1835	NATURAL		23.30/(.917)	19.20/(.756)	17.00/(.669)	19.00/(.748)	
20	71226-2035	NATURAL		25.30/(.996)	21.20/(.835)	19.00/(.748)	21.00/(.827)	
22	71226-2235	NATURAL		27.30/(1.075)	23.20/(.913)	21.00/(.827)	23.00/(.906)	
24	71226-2435	NATURAL		29.30/(1.154)	25.20/(.992)	23.00/(.906)	25.00/(.984)	
26	71226-2635	NATURAL		31.30/(1.232)	27.20/(1.071)	25.00/(.984)	27.00/(1.063)	
28	71226-2835	NATURAL		33.30/(1.311)	29.20/(1.150)	27.00/(1.063)	29.00/(1.142)	
30	71226-3035	NATURAL		35.30/(1.390)	31.20/(1.228)	29.00/(1.142)	31.00/(1.220)	
40	71226-4035	NATURAL	X	45.30/(1.783)	41.20/(1.622)	39.00/(1.536)	41.00/(1.614)	
26	71226-2675	NATURAL		31.30/(1.232)	27.20/(1.071)	25.00/(.984)	27.00/(1.063)	

2.25±0.20
(.089±.008)

3.15±0.20
(.124±.008)

2.77±0.20
(.109±.008)

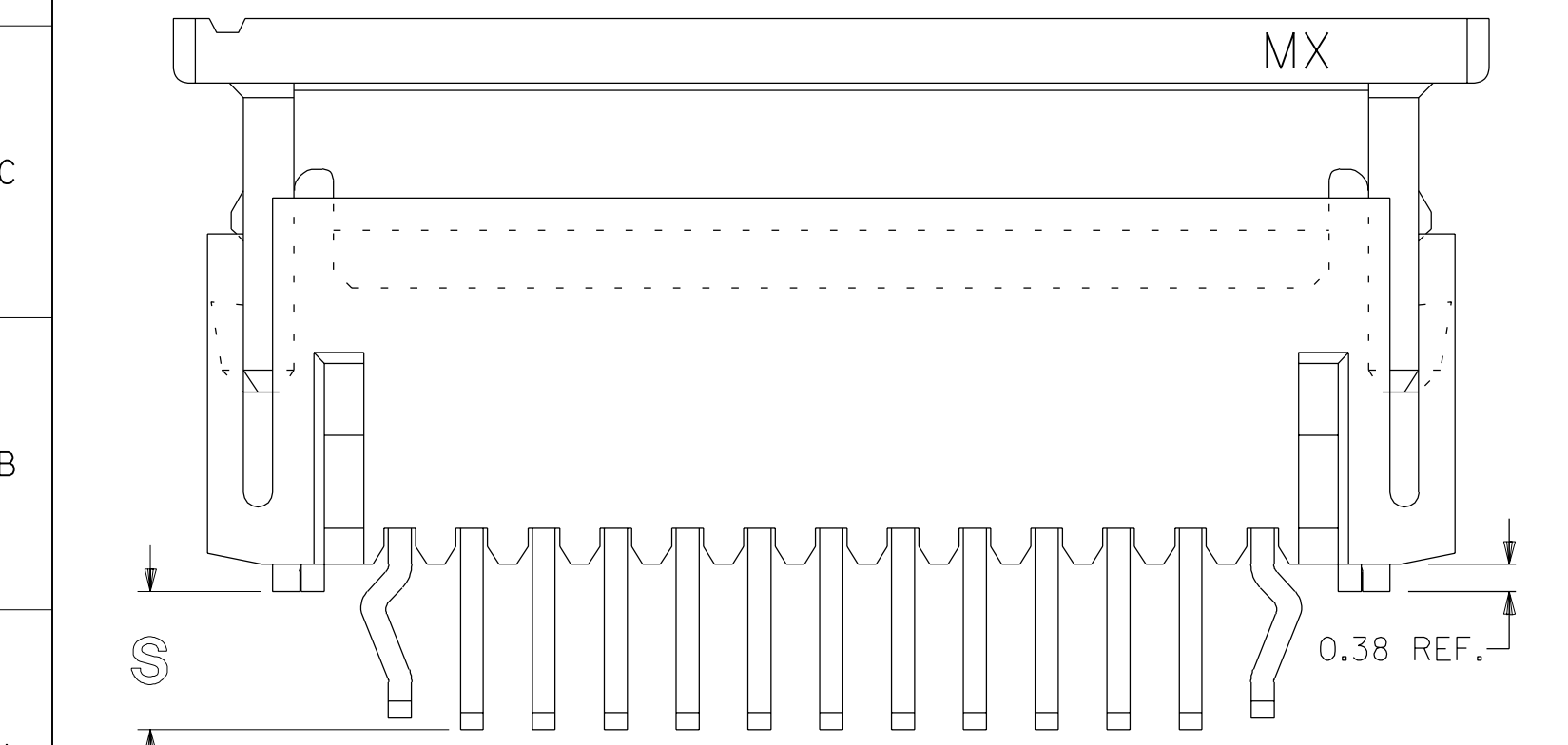

STAND-OFF OPTION (71226-2675 SHOWN)
SEE SHEET 1 FOR DIMENSION NOT SHOWN

PACKAGED IN TRAYS PER PK-70873-0246

F		SEE SHEET 1	B	SEE SHEET 1	UNLESS OTHERWISE SPECIFIED TOLERANCES: ANGULAR ± 1/2°		▽ = 0	▼ = 0	REVISE ONLY ON CAD SYSTEM
D		SEE SHEET 1	AI	SEE SHEET 1	INCH METRIC		TITLE		
CI		SEE SHEET 1	A	SEE SHEET 1	3 PLACE ± — —		1.00mm/(.039) PITCH, ZIF, FFC CONNECTOR		
LTR.		REVISIONS	LTR.	REVISIONS	2 PLACE ± — —		MOLEX INCORPORATED		
					1 PLACE — — ± — —		SHEET NO. 2		
					DRAFT WHERE APPLICABLE MUST REMAIN WITHIN DIMENSIONS		DATE 12/16/92		
					DRWG. BY GLT		PART NO. SD-71226-***5		
					CHK'D. BY CAB		DRWG. NO.		
					APP'D. BY CAB		SEE CHART		
					SCALE		FILE NAME SD7122608 DGN		
							THIS DRAWING CONTAINS INFORMATION THAT IS PROPRIETARY TO MOLEX INC. AND SHOULD NOT BE USED WITHOUT WRITTEN PERMISSION.		
							DIV. CPP		

13 12 11 10 9 8 7 6 5 4 3 2 1