

REV.	DESCRIPTION	DATE	APPROVED
D	Engineering Update w/o Changes	02/27/04	M. C.
E	Removed Material Code	05/28/16	J. C.

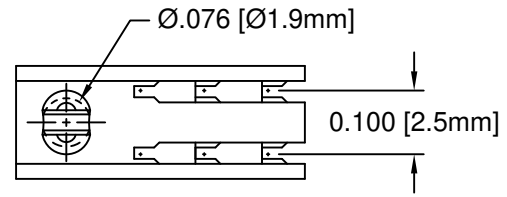
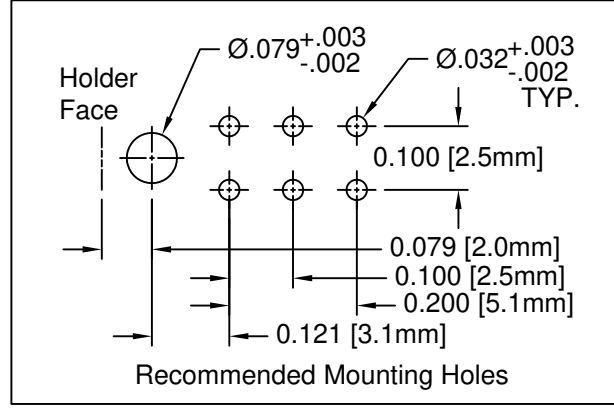
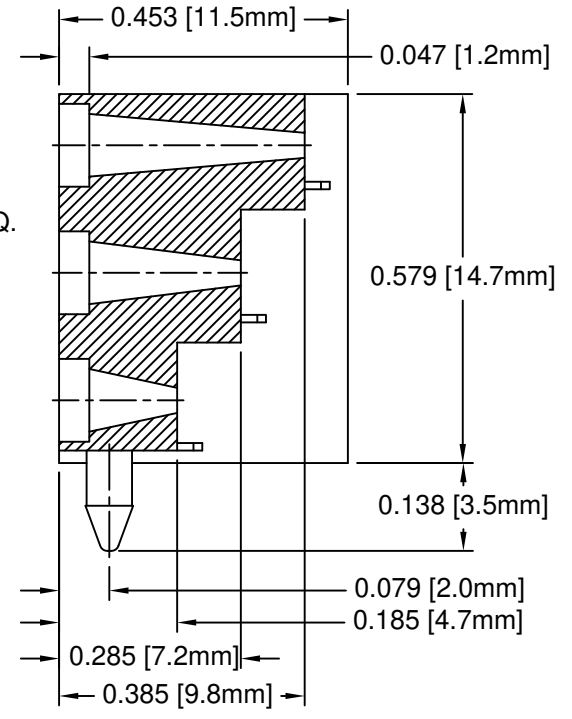
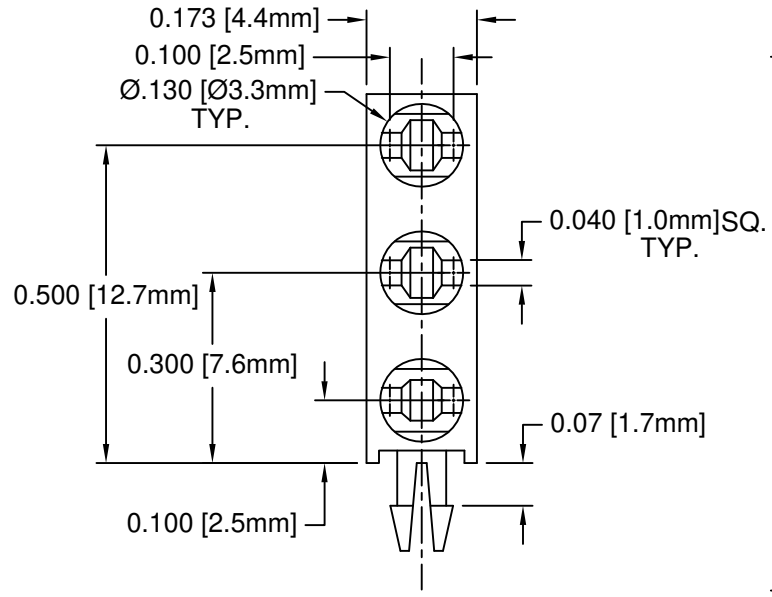

- 2. MATERIAL: NYLON 6/6, 94V-0, BLACK.
- 1. GENERAL SPECIFICATIONS: BIVAR MOLDED COMPONENT SPECIFICATION BV00-E101.

STANDARD TOLERANCE (UNLESS OTHERWISE SPECIFIED)		BIVAR®	
DECIMALS	ANGULAR	4 THOMAS, IRVINE, CA. 92618	
.X ±.1	X° ±1°	TEL: (949) 951-8808 FAX: (949) 951-3974	
.XX ±.01		<b>TITLE:</b> TRI-LEVEL T-1 (3mm) LED HOLDER	
.XXX ±.005		<b>PART NO:</b> H-320C-LP	
DESIGNED: <b>S. Irving</b>	DATE: <b>06/24/02</b>	<b>REVISION:</b> E	
CHECKED: <b>M. Chen</b>	DATE: <b>06/25/02</b>	<b>CAGE CODE :</b> 32559	<b>SHEET #</b> 1 OF 1
CAD GENERATED DOCUMENT. DO NOT MEASURE DRAWING.			