

THIS DRAWING IS UNPUBLISHED. RELEASED FOR PUBLICATION  
 © COPYRIGHT - By - ALL RIGHTS RESERVED.

LOC		DIST		REVISIONS			
P	LTR	DESCRIPTION		DATE	DWN	APVD	
AF	50	J5		REVISED PER ECR-12-013486	06JAN13	KH	KR

SUGGESTED MATING TAB

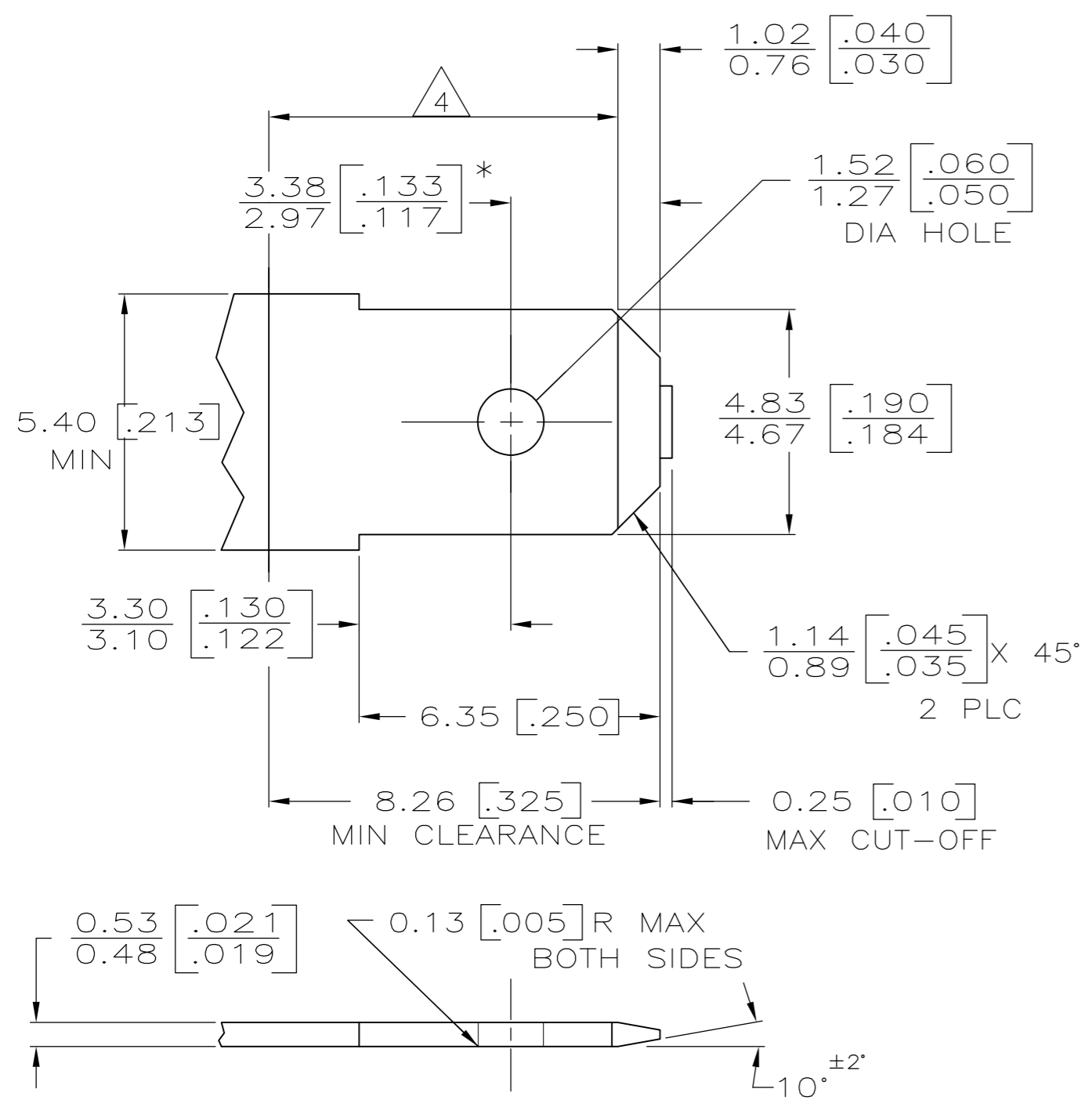

- 1 MATL: #2 HARD BRASS OR NICKEL PLATE STEEL.
- 2 NO BURRS PERMISSIBLE AT HOLE.
- 3 TIN PLATING IS REQUIRED ON BRASS WHEN TERMINAL TEMPERATURE IS OVER 225° F.
- 4 MUST BE FLAT WITHIN 0.076 [0.003] OVER THIS LENGTH.
- 5 HOLE MUST BE SYMMETRICAL ABOUT TAB  $\phi$  WITHIN 0.076 [0.003]
- \* TO BE USED ONLY WHEN SHOULDER IS ELIMINATED.

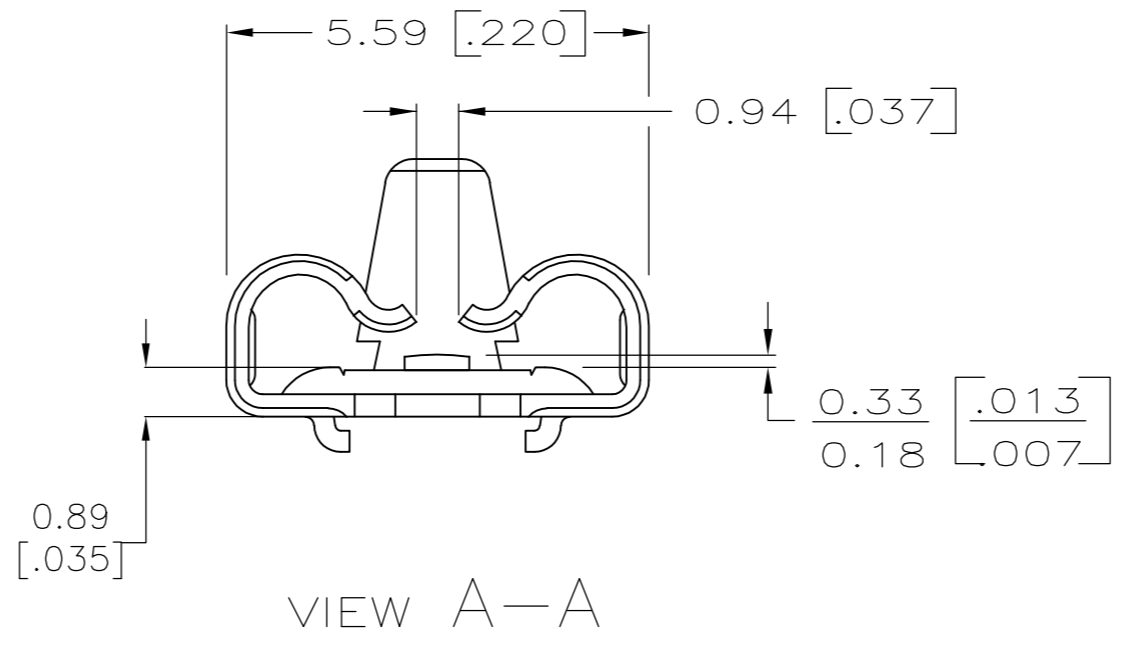
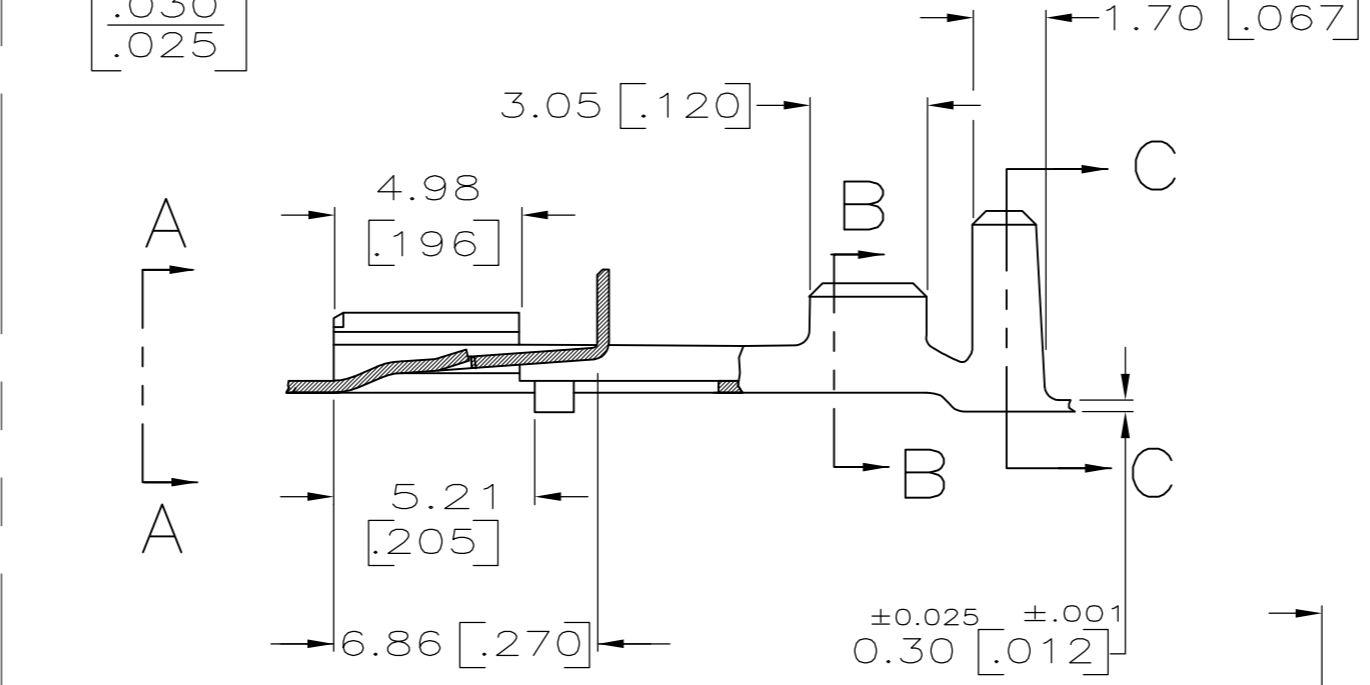
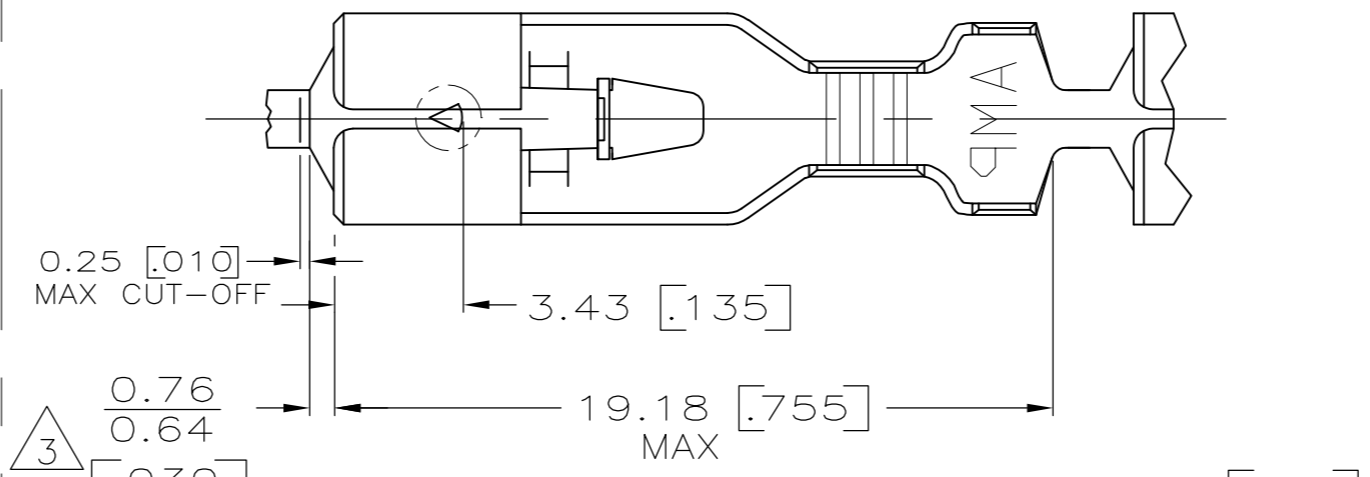

- 1 DIMENSIONS IN BRACKETS ARE IN INCHES.
- 2 CONTINUOUS STRIP ON REELS.
- 3 THE 0.76 [0.030] / 0.64 [0.025] DIMENSION MUST BE MAINTAINED BY THE APPLICATOR CUT-OFF TO ENSURE THE PROPER LOCKING FUNCTION OF THE RECEPTACLE.
- 4 WIRE SIZE IS FOR A [#24-#20] AWG.
- 5 INSULATION RANGE IS 1.52-2.79 [0.060-.110] DIA.
- 6 GOLD PLATE 0.00127 [0.000050] MIN THK OVER 0.00127 [0.000050] MIN NICKEL PL.
- 7 GOLD FLASH PL. 0.00012 [0.000005] MIN THK OVER 0.00127 [0.000050] MIN NICKEL PL
- 8 PRELIMINARY - NOT FOR PRODUCTION

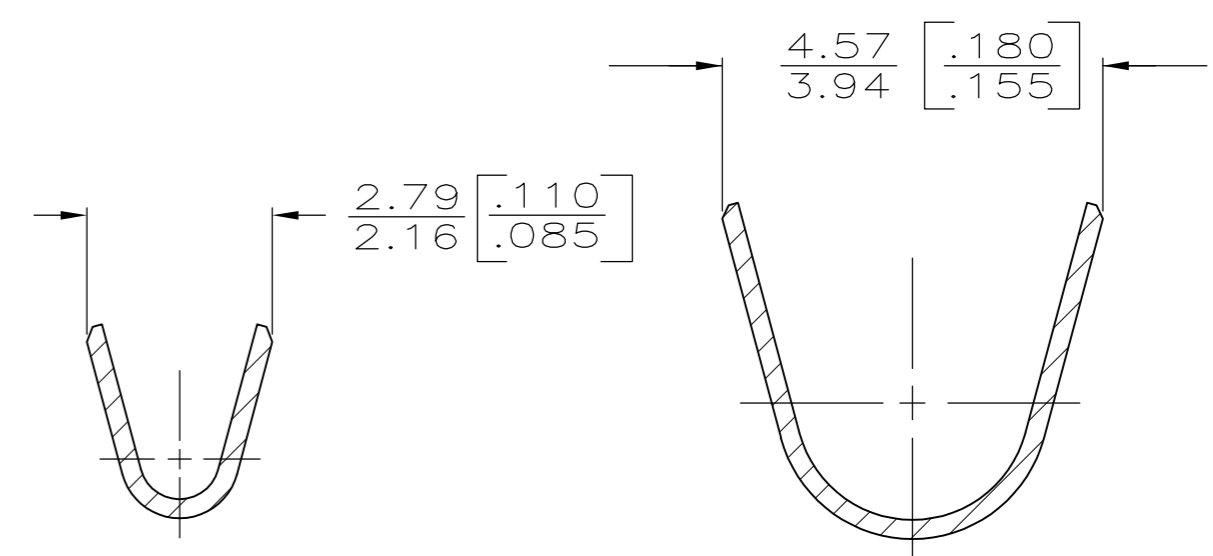

SECTION B-B

SECTION C-C

GOLD / NICKEL 7	BRASS	8	63196-5
---	BRASS		63196-4
GOLD / NICKEL 6	BRASS	8	63196-3
PRE-TIN	BRASS		63196-2
TIN	BRASS		63196-1
FINISH	MATERIAL		PART NO.

DIMENSIONS:		TOLERANCES UNLESS OTHERWISE SPECIFIED:		DWN		TE Connectivity	
mm [INCHES]				CHK	DATE	RECEPTACLE, POSITIVE LOCK, .187 SERIES	
		0 PLC	± -	JR RUTH	2/28/87	SIZE	RESTRICTED TO
		1 PLC	± -	G YETTER	3/9/87	A2	
		2 PLC	± -	R KUZO	3/9/87	CAGE CODE	
		3 PLC	± 0.25 .010			00779	
		4 PLC	± -			DRAWING NO	
		ANGLES	± -			C=63196	
MATERIAL	SEE TABLE	FINISH	SEE TABLE			SCALE	
						5:1	
						SHEET	
						1 of 1	
						REV	
						J5	