

# OV9732 720p HD product brief



## Power-Efficient and Compact HD CameraChip™ Sensor for Battery-Powered Smart-Home and Security Applications



available in  
a lead-free  
package

OmniVision's OV9732 is a low-power and ultra-compact CameraChip™ sensor that brings 720p high definition (HD) video to mainstream security systems and wireless battery-powered smart-home cameras. Compared to the previous generation OV9712, the OV9732 is 35 percent smaller and delivers dramatically improved pixel performance.

The OV9732 CameraChip sensor utilizes OmniPixel3-HS™ high sensitivity 3.0 μm pixel technology to bring industry-leading scene reproduction to a wide range of security and lifestyle camera

applications that operate in extremely high- and low-light conditions. The sensor's narrow 9-degree chief ray angle (CRA) supports consumer-grade optical lens systems and reduces image artifacts for enhanced performance.

When operating in low-power mode, the 1/4-inch OV9732 requires just 99 mW to capture 720p HD video at 30 frames per second.

Find out more at [www.ovt.com](http://www.ovt.com).



## Applications

- IP Cameras
- Life Style Cameras
- Surveillance
- Motion Cameras

## Product Features

- support for image sizes: full size (1280x720), VGA (640x480), 2x2 RGB binning (640x360)
- support for output formats: 10-bit RAW output with 1-lane MIPI and DVP
- on-chip phase lock loop (PLL)
- programmable controls for frame rate, mirror and flip, gain/exposure, and windowing
- support for horizontal and vertical sub-sampling
- low power mode (LPM) function
- capable of maintaining register values at software power down
- standard SCCB interface
- GPIO tri-state configurability and programmable polarity
- FSIN
- image quality control: defect pixel correction (DPC) and automatic black level calibration (ABLC)

# OV9732



## Ordering Information

- OV09732-H35A (color, lead-free, 35-pin CSP5)

## Product Specifications

- active array size: 1280 x 720
- power supply:
  - core: 1.7 - 1.9V (1.8V normal)
  - analog: 2.7 - 2.9V (2.8V normal)
  - I/O: 1.7 - 1.9V (1.8V normal)
- power requirements:
  - active: 99 mW
  - standby: 36  $\mu$ W
- temperature range:
  - operating: -30°C to +70°C junction temperature
  - stable image: 0°C to +50°C junction temperature
- output formats: 10-bit RAW RGB
- lens size: 1/4"
- lens chief ray angle: 9°
- input clock frequency: 6 - 27 MHz
- maximum image transfer rate: 30 fps
- sensitivity: 2.066 V/lux-sec
- scan mode: progressive
- shutter: rolling shutter
- max S/N ratio: 39 dB
- dynamic range: 72 dB @ 8x gain
- maximum exposure interval: 798 x  $t_{row}$
- pixel size: 3  $\mu$ m x 3  $\mu$ m
- dark current: 5 mV/sec @ 60°C junction temperature
- image area: 3888  $\mu$ m x 2208  $\mu$ m
- package dimensions: 4704  $\mu$ m x 2994  $\mu$ m

## Functional Block Diagram

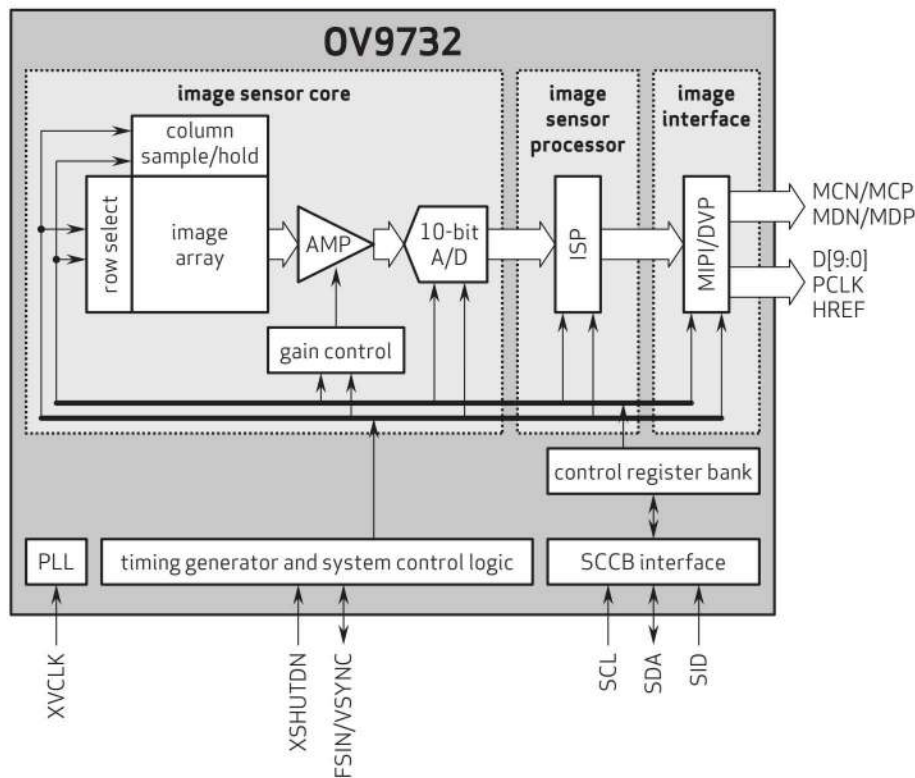

4275 Burton Drive  
Santa Clara, CA 95054  
USA

Tel: +1 408 567 3000  
Fax: +1 408 567 3001  
www.ovt.com

OmniVision reserves the right to make changes to their products or to discontinue any product or service without further notice. OmniVision is a registered trademark of OmniVision Technologies, Inc. The OmniVision logo and PureCel are trademarks of OmniVision Technologies, Inc. All other trademarks are the property of their respective owners.



OmniVision