

DESCRIPTION

The EV6922DS-01A is an evaluation board for the MP6922DS. It is configured to provide synchronous rectification solution for LLC topology.

MP6922DS features dual synchronous gate outputs which enables high efficiency rectification by replacing the schottky rectifier with a low Ron MOSFET.

ELECTRICAL SPECIFICATIONS

Parameter	Symbol	Value	Units
Vcc Voltage	V _{CC}	8–24	V
Switching Frequency	F _{SW}	<300	kHz

FEATURES

- Works with both Standard and Logic Level FETS
- Compatible with Energy Star, 1W Standby Requirements
- V_{DD} Range From 8V to 24V
- Fast Turn-off Total Delay of 20ns
- Max 300kHz Switching Frequency
- <600µA Quiescent Current at Light Load Mode
- Supports CCM, CrCM and DCM Operation Mode
- Supports High-side and Low-side Rectification

APPLICATIONS

- AC-DC Adapter
- LCD & PDP TV
- TeleCom SMPS

All MPS parts are lead-free and adhere to the RoHS directive. For MPS green status, please visit MPS website under Products, Quality Assurance page. "MPS" and "The Future of Analog IC Technology" are registered trademarks of Monolithic Power Systems, Inc.

EV6922DS-01A EVALUATION BOARD

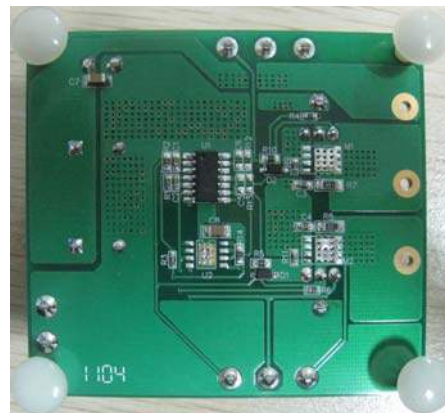

(L x W x H) 1.14" x 1.14" x 0.6"
7.1cm x 6.5cm x 2cm

Board Number	MPS IC Number
EV6922DS-01A	MP6922DS

EVALUATION BOARD SCHEMATIC

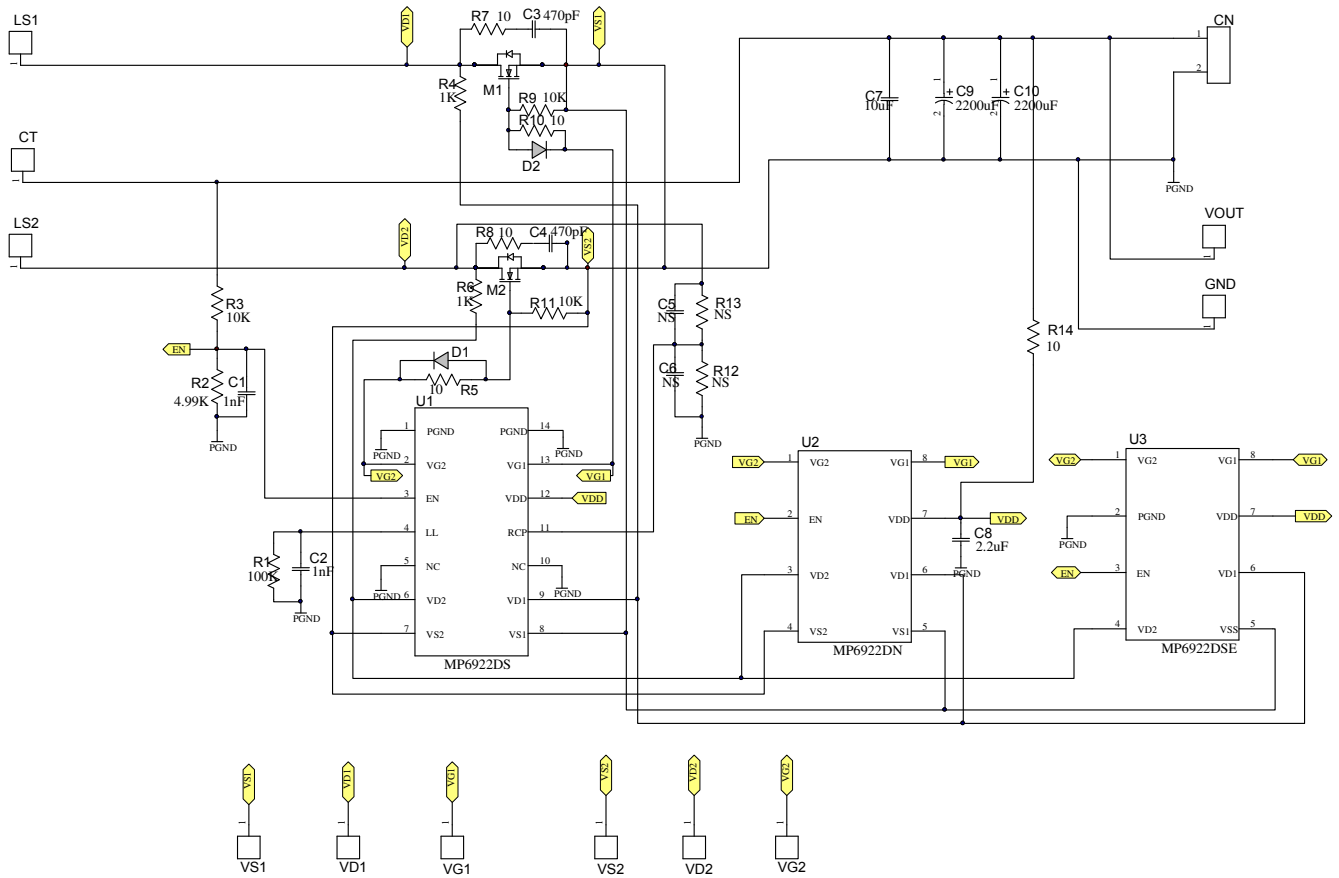

EV6922DS-00A BILL OF MATERIALS

Qty	Ref	Value	Description	Package	Manufacturer	Manufacturer P/N
2	C1, C2	1nF	Ceramic Capacitor, 50V, X7R	0603	muRata	GRM188R71H102KA01D
2	C3, C4	470pF	Ceramic Capacitor, 50V, X7R	0603	muRata	GRM188R71H471KA01D
0	C5, C6	NS	No Stuffed	0603		
1	C7	10µF	Ceramic Capacitor, 25V, X5R	1206	muRata	GRM31CR61E106KA12L
1	C8	2.2µF	Ceramic Capacitor, 25V, X7R	1206	TDK	C3216X7R1E225K
2	C9, C10	2200µF	Electrolytic Capacitor, 35V	DIP	Rubycon	2200µF/35V Dia.: 16mm Pin-pin:7.5mm
2	D1, D2		Diode;75V, 0.15A	SOD-123	Diodes	1N4148W
2	M1, M2		N Channel Mosfet, 60V	TO-220	AM90N06-10P	Analog Power
		NS	N Channel Mosfet, 60V	PowerPAK SOIC8		
1	R1	100k	Film Resistor, 1%	0603	Yageo	RC0603FR-07100KL
1	R2	4.99k	Film Resistor, 1%	0603	Yageo	RC0603FR-074K99L
3	R3, R9, R11	10k	Film Resistor, 1%	0603	Yageo	RC0603FR-0710KL
2	R4, R6	1k	Film Resistor, 5%	0603	Royalohm	0603SAJ0102T5E
3	R5, R10, R14	10	Film Resistor, 5%	0603	Royalohm	0603SAJ0100T5E
2	R7, R8	10	Film Resistor, 5%	1206	Yageo	RC1206JR-0710R
0	R12, R13	NS	Film Resistor, 1%	0603	Yageo	RC0603FR-07137KL
1	U1		SR Controller	SOIC14	MPS	MP6922DS R0
0	U2	NS	SR Controller	SOIC8	MPS	MP6922DN
0	U3	NS	SR Controller	SOIC8	MPS	MP6922DSE
2			M1, M2 Radiator			
2			M1, M2 Isolation Gasket			
2			M1, M2 Screw			
4			Board Stanchion			

PRINTED CIRCUIT BOARD LAYOUT

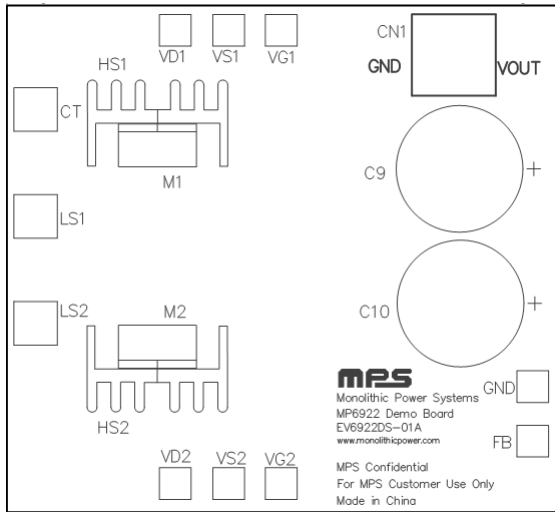

Figure 1—Top Silk Layer

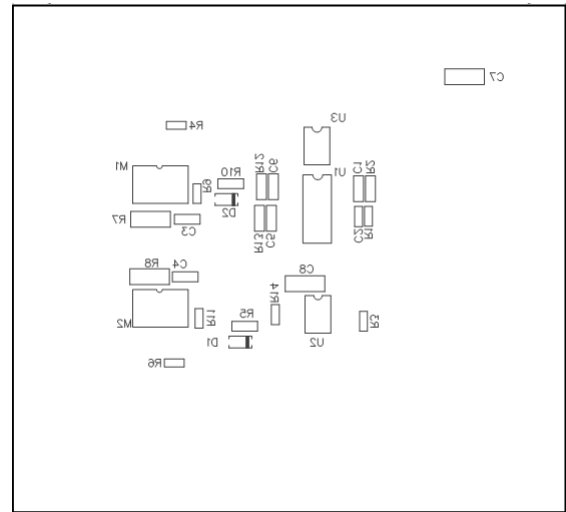

Figure 2—Bottom Silk Layer

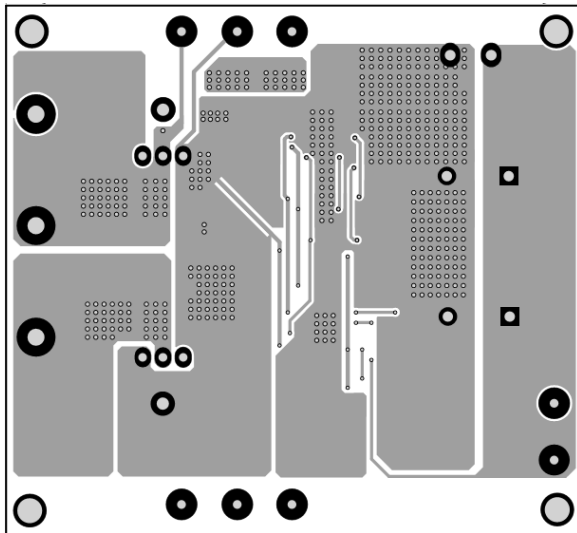

Figure 3—Top Layer

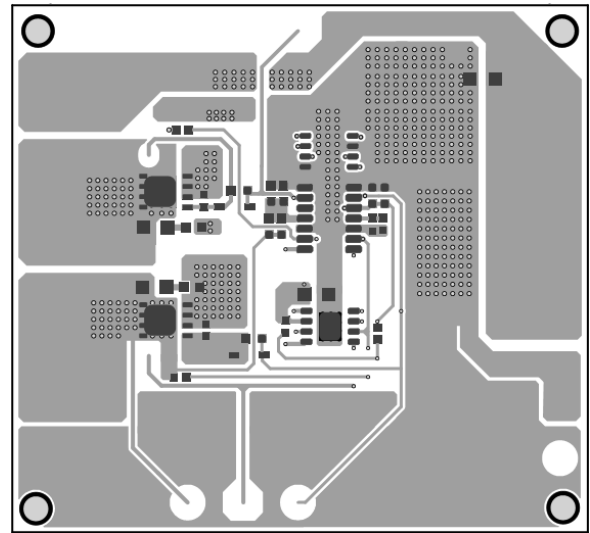

Figure 4—Bottom Layer

QUICK START GUIDE

The demo board is intended to implement the synchronous rectifier in an LLC resonant converter with center-tap secondary winding. If the converters implement diode rectification,

1. Remove the diode rectifiers from the board as the Fig.5 shows.
2. Connect the center-tap and other two secondary windings of transformer as the Fig.6 shows.
3. Connect the Vout and GND pins on MP6922 demo board as the Fig. 6 shows.
4. Turn the power supply on. The IC will start up automatically.

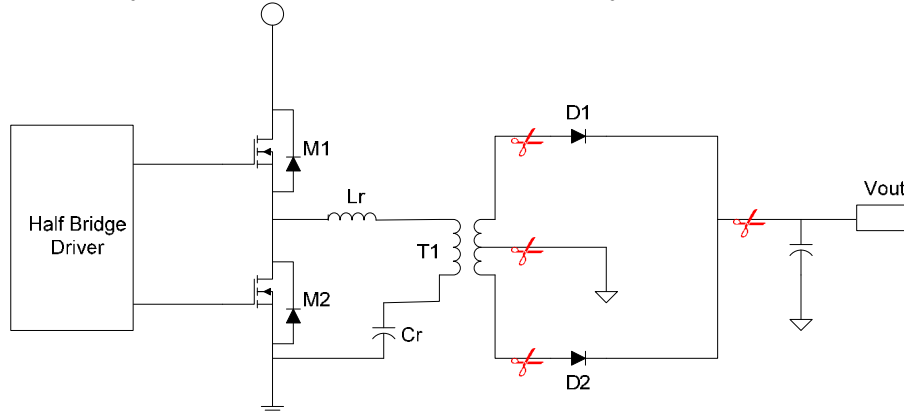

Figure 5—How to disconnect the diode rectifiers

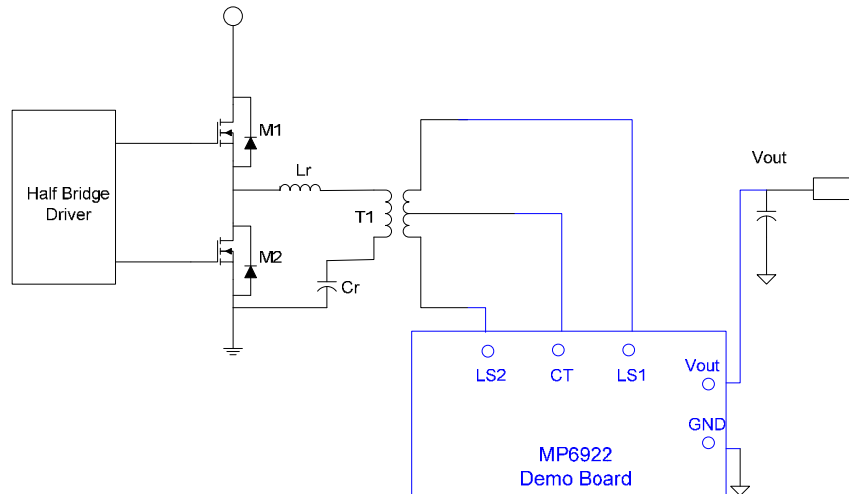

Figure 6—How to connect the EV6922DS-00A

NOTICE: The information in this document is subject to change without notice. Users should warrant and guarantee that third party Intellectual Property rights are not infringed upon when integrating MPS products into any application. MPS will not assume any legal responsibility for any said applications.