

SCREW ON RECEPTACLE

R223.555.000

FRONT MOUNTING

Series : MMBX

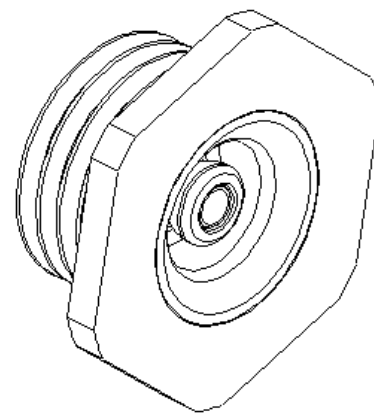
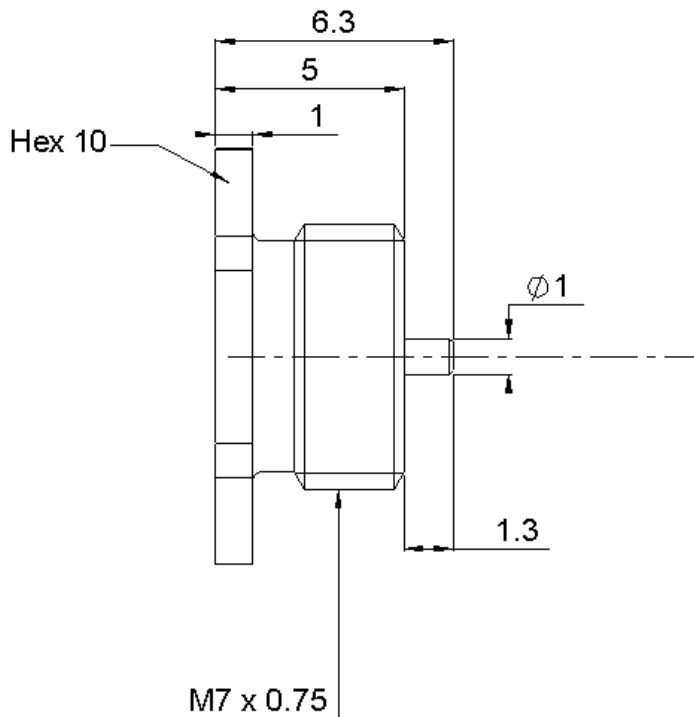

PANEL CUT OUT

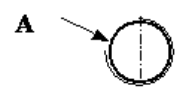

Threading

Ø A	M7 x 0.75
-----	-----------

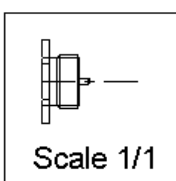

All dimensions are in mm.

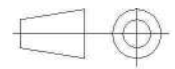

COMPONENTS	MATERIALS	PLATING (µm)
BODY	BRASS	NPGR
CENTER CONTACT	BRASS	NPGR
OUTER CONTACT	BRASS	NPGR
INSULATOR	LIQUID CRYSTAL POLYMER,PTFE	
GASKET		
OTHERS PARTS		
-	-	-
-	-	-

Issue : 0735 B

In the effort to improve our products, we reserve the right to make changes judged to be necessary.



SCREW ON RECEPTACLE

R223.555.000

FRONT MOUNTING

Series : MMBX

PACKAGING

SPECIFICATION

Standard	Unit	Other
100	'W' option	Contact us

ELECTRICAL CHARACTERISTICS

ENVIRONMENTAL

Impedance	50	Ω
Frequency	0-12.4	GHz
VSWR	1.083 + 0,0000	x F(GHz) Maxi
Insertion loss	0.12	$\sqrt{F}(\text{GHz})$ dB Maxi
RF leakage	- (100)	- F(GHz)) dB Maxi
Voltage rating	330	Veff Maxi
Dielectric withstanding voltage	500	Veff mini
Insulation resistance	1000	M Ω mini

Operating temperature	-55/+155	$^{\circ}\text{C}$
Hermetic seal	NA	Atm.cm3/s
Panel leakage	NA	

OTHER CHARACTERISTICS

Assembly instruction **NA**

Others :
to 6 GHz
Interface only up to 2.5 GHz

MECHANICAL CHARACTERISTICS

Center contact retention		
Axial force – Mating end	10	N mini
Axial force – Opposite end	7	N mini
Torque	NA	N.cm mini
Recommended torque		
Mating	NA	N.cm
Panel nut	60	N.cm
Mating life	500	Cycles mini
Weight	1,3200	g

Issue : 0735 B

In the effort to improve our products, we reserve the right to make changes judged to be necessary.

RADIALL 