

LOC	DIST	REVISIONS			
GP	00	REV	DESCRIPTION	DATE	BY
E		1	REVISED PER ECO-12-021104	22JAN2013	CJV

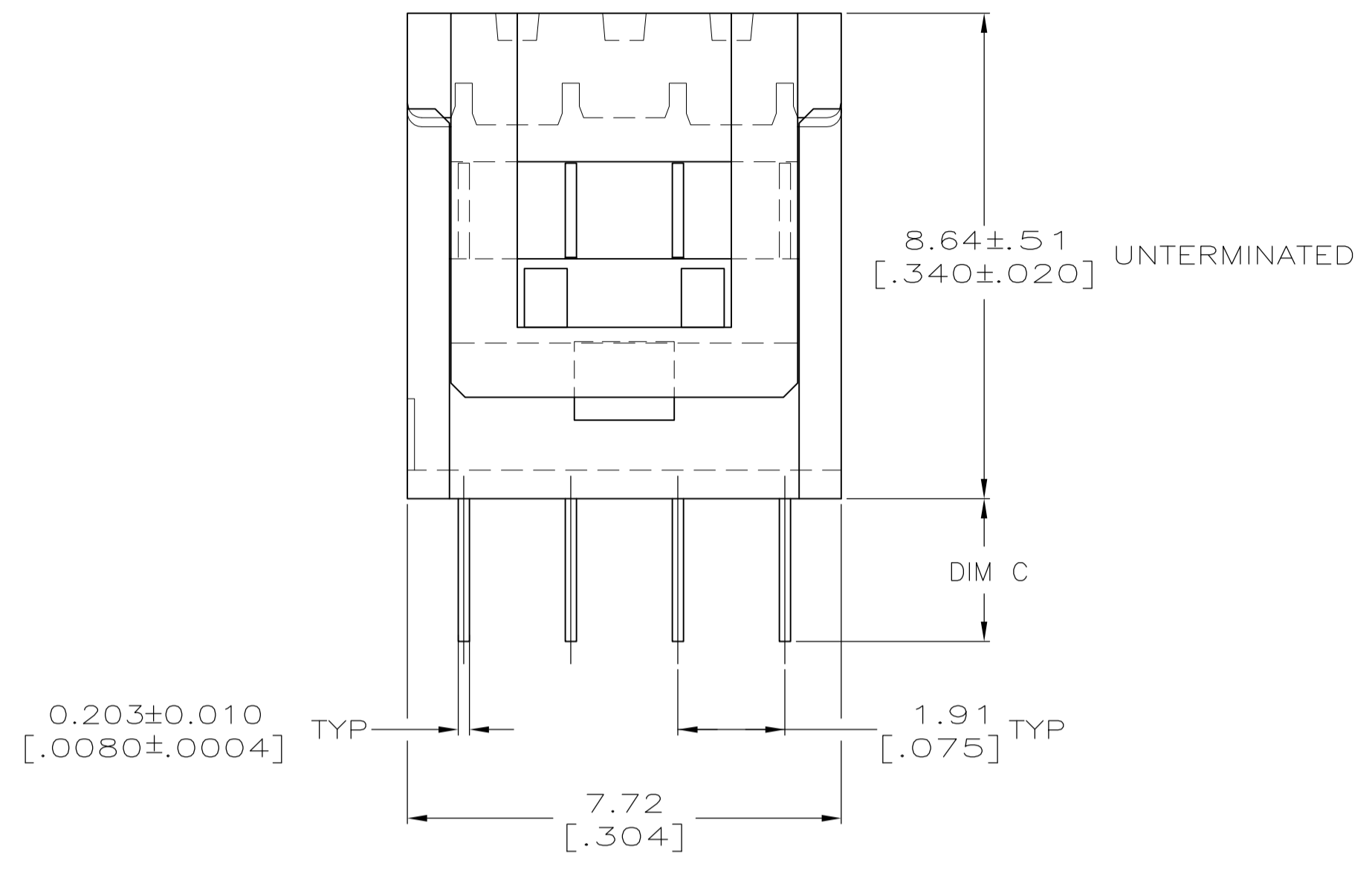

- △ HOUSING: UL RATED 94V-0 LCP THERMOPLASTIC, COLOR BLACK.
COVER: UL RATED 94V-0 POLYESTER MOLDING COMPOUND, COLOR BLACK.
- △ CONTACTS: COPPER ALLOY.
- △ CONTACTS: 0.00254 [.000100] MIN MATTE TIN OVER 0.00127 [.000050] MIN NICKEL.
- △ POSITION 1 INDICATOR, OMITTED FOR PART NUMBER 2-5111595-1.
- △ VOID CORES MAY OR MAY NOT BE PRESENT BETWEEN ANY 2 ROWS OF CONTACTS.

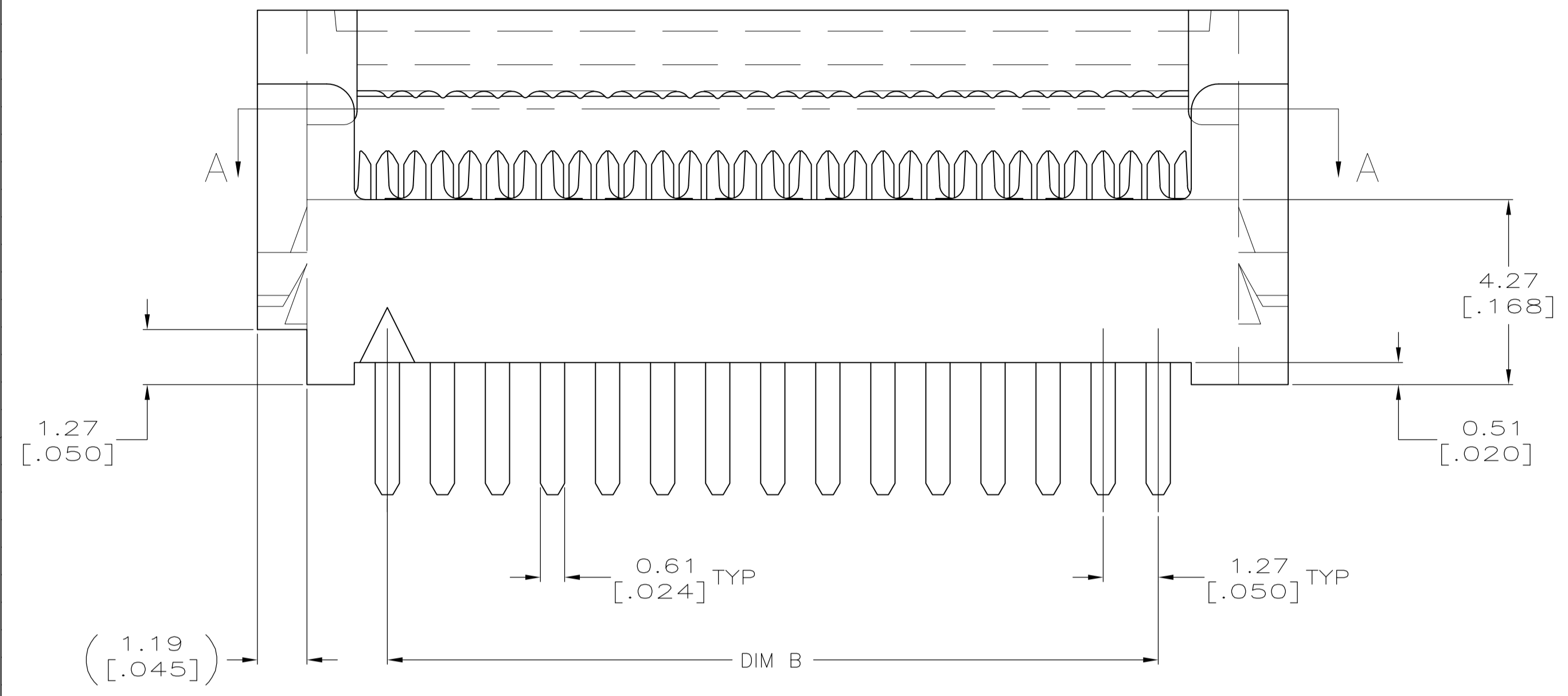
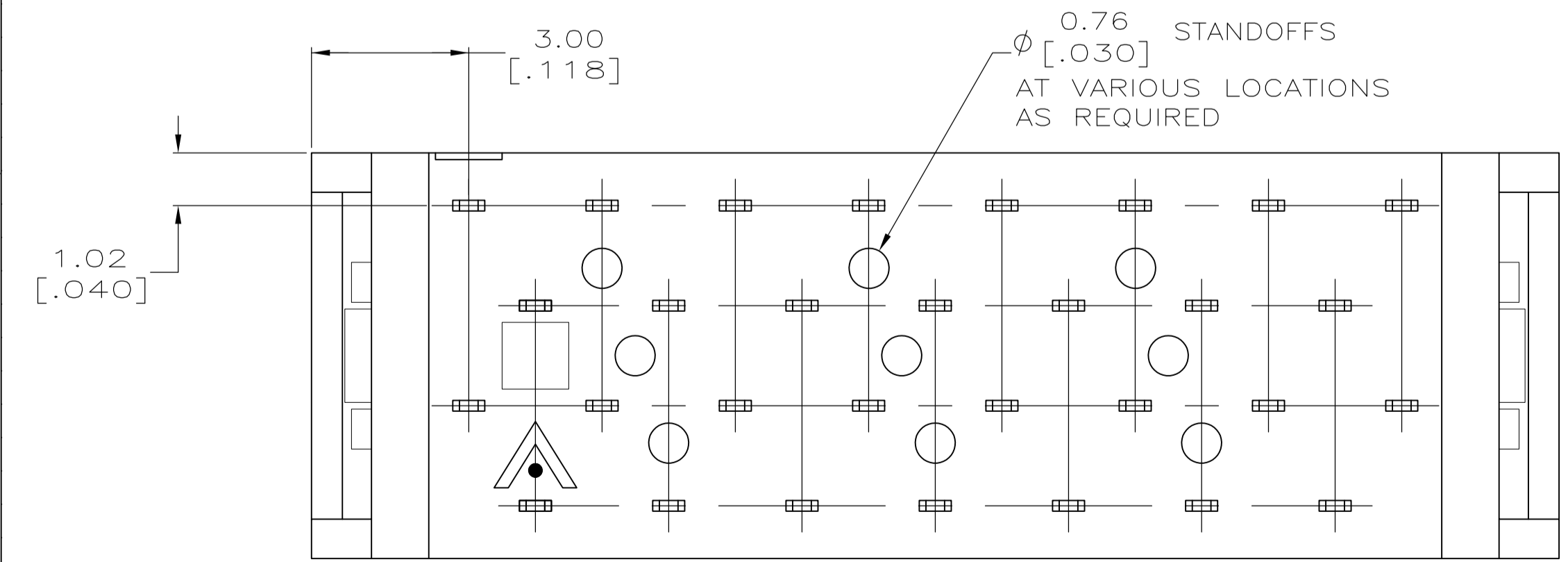
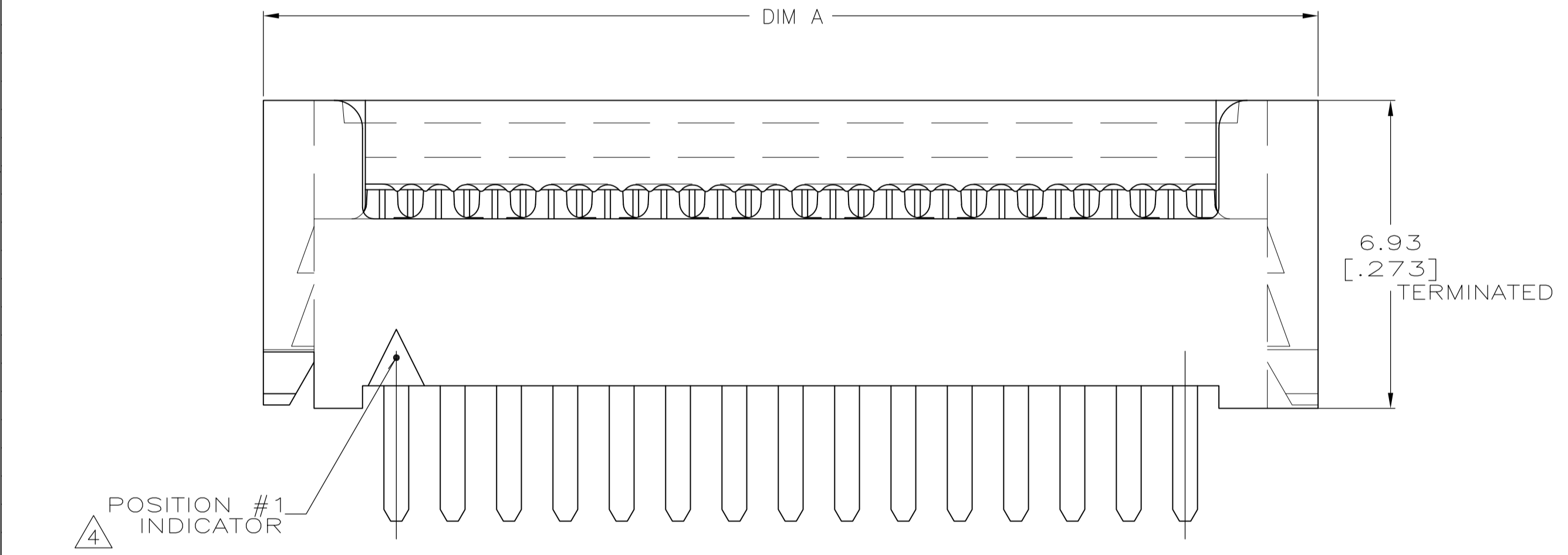

PRELIMINARY	#1	3.30 [.130]	30.48 [1.200]	36.47 [1.436]	50	2-5111595-5
	#1	3.30 [.130]	5.08 [.200]	11.07 [.436]	10	2-5111595-4
	#2	3.30 [.130]	49.53 [1.950]	55.52 [2.186]	80	2-5111595-2 △
	#2	2.54 [.100]	41.91 [1.650]	47.90 [1.886]	68	2-5111595-1
	#2	2.54 [.100]	16.51 [.650]	22.50 [.886]	28	2-5111595-0
	#2	2.54 [.100]	41.91 [1.650]	47.90 [1.886]	68	1-5111595-9
	#1	2.54 [.100]	27.94 [1.100]	33.93 [1.336]	46	1-5111595-7
	#2	2.54 [.100]	62.23 [2.450]	68.22 [2.686]	100	1-5111595-6
	#2	2.54 [.100]	49.53 [1.950]	55.52 [2.186]	80	1-5111595-5
	#2	2.54 [.100]	44.45 [1.750]	50.44 [1.986]	72	1-5111595-4
	#2	2.54 [.100]	39.37 [1.550]	45.36 [1.786]	64	1-5111595-3
	#2	2.54 [.100]	36.83 [1.450]	42.82 [1.686]	60	1-5111595-2
	#1	2.54 [.100]	30.48 [1.200]	36.47 [1.436]	50	1-5111595-1
	#2	2.54 [.100]	26.67 [1.050]	32.66 [1.286]	44	1-5111595-0
	#2	2.54 [.100]	24.13 [.950]	30.12 [1.186]	40	5111595-9
	#1	2.54 [.100]	20.32 [.800]	26.31 [1.036]	34	5111595-8
	#1	2.54 [.100]	17.78 [.700]	23.77 [.936]	30	5111595-7
	#1	2.54 [.100]	15.24 [.600]	21.23 [.836]	26	5111595-6
	#2	2.54 [.100]	13.97 [.550]	19.96 [.786]	24	5111595-5
	#2	2.54 [.100]	11.43 [.450]	17.42 [.686]	20	5111595-4
	#2	2.54 [.100]	8.89 [.350]	14.88 [.586]	16	5111595-3
	#1	2.54 [.100]	7.62 [.300]	13.61 [.536]	14	5111595-2
	#1	2.54 [.100]	5.08 [.200]	11.07 [.436]	10	5111595-1
	PCB LAYOUT	C	B	A	POSN	PART NO

THIS DRAWING IS A CONTROLLED DOCUMENT. DIMENSIONING AND TOLERANCING PER ASME Y14.5M-2009.

STE TE Connectivity

AMPMODU® SYSTEM 50, CONNECTOR, PADDLEBOARD

108-1109

114-25040

00779-5111595

SCALE 10:1 SHEET 1 OF 2 REV E

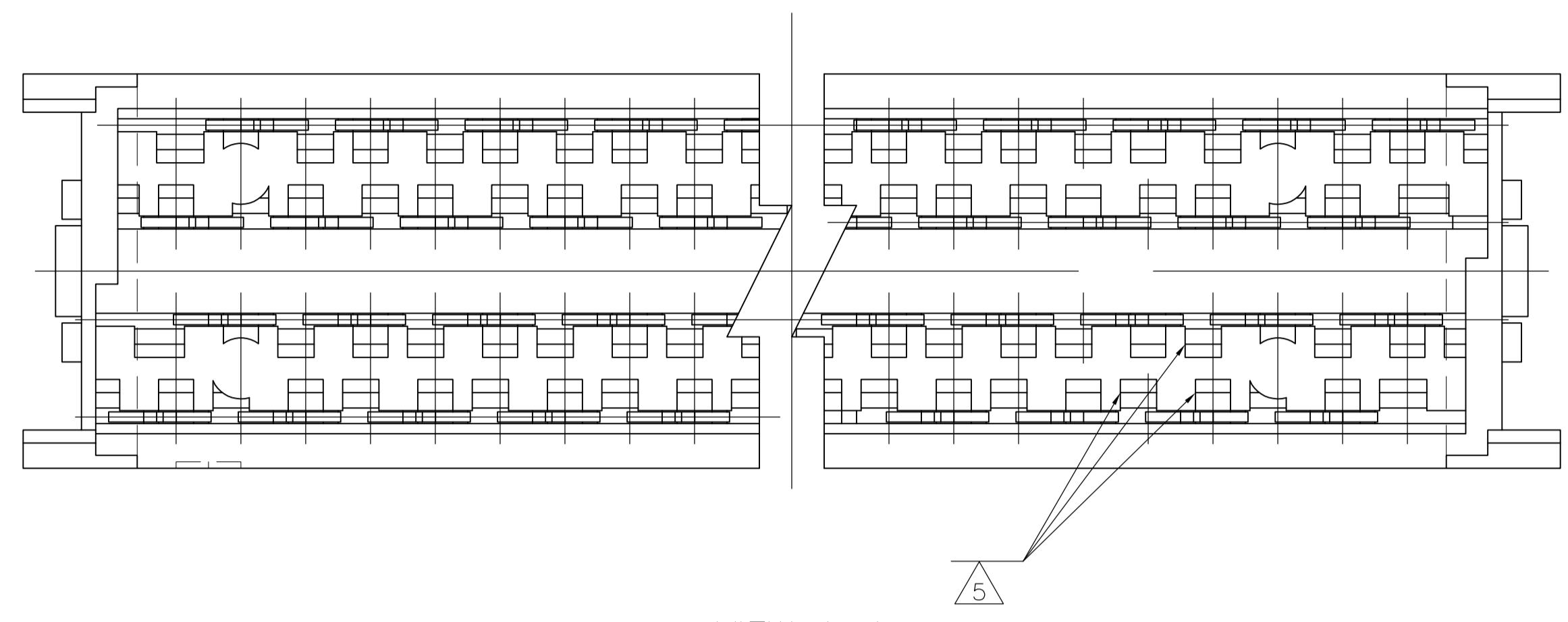

VIEW A-A
(COVER REMOVED FOR CLARITY)

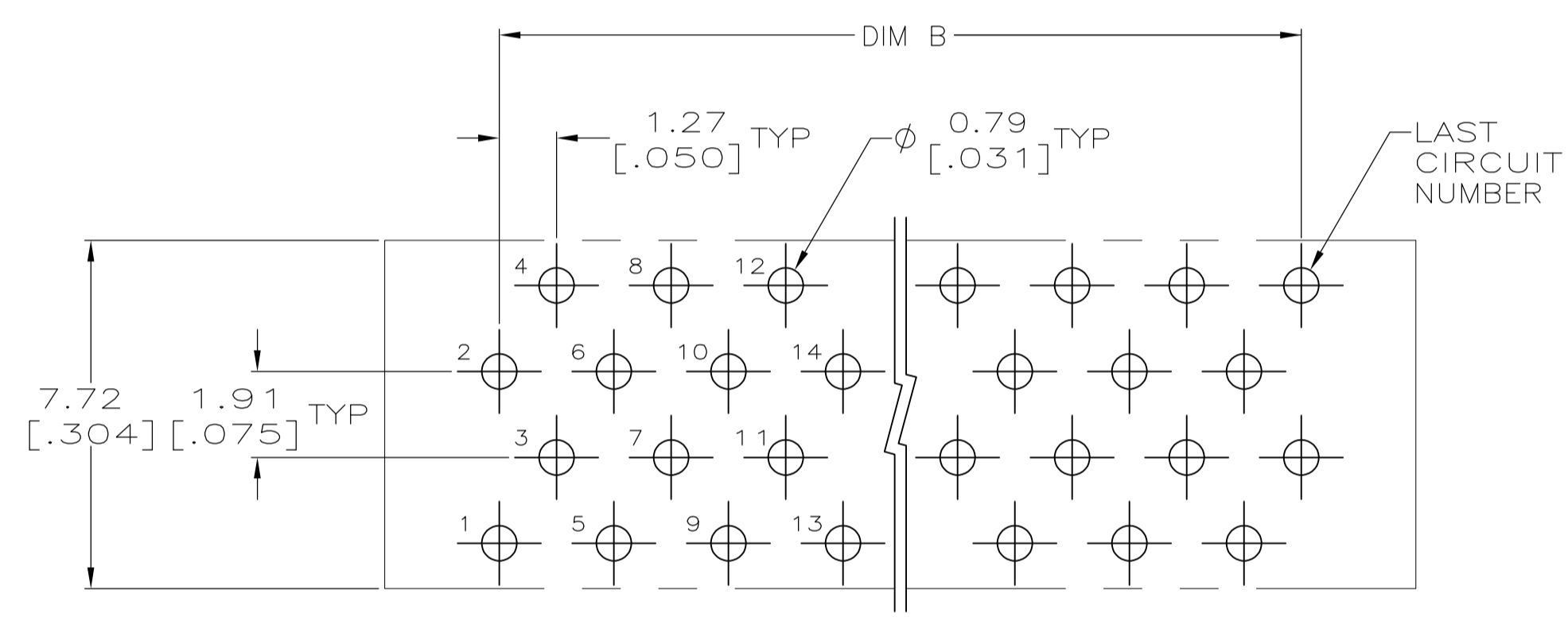

PRINTED CIRCUIT BOARD HOLE LAYOUT #2

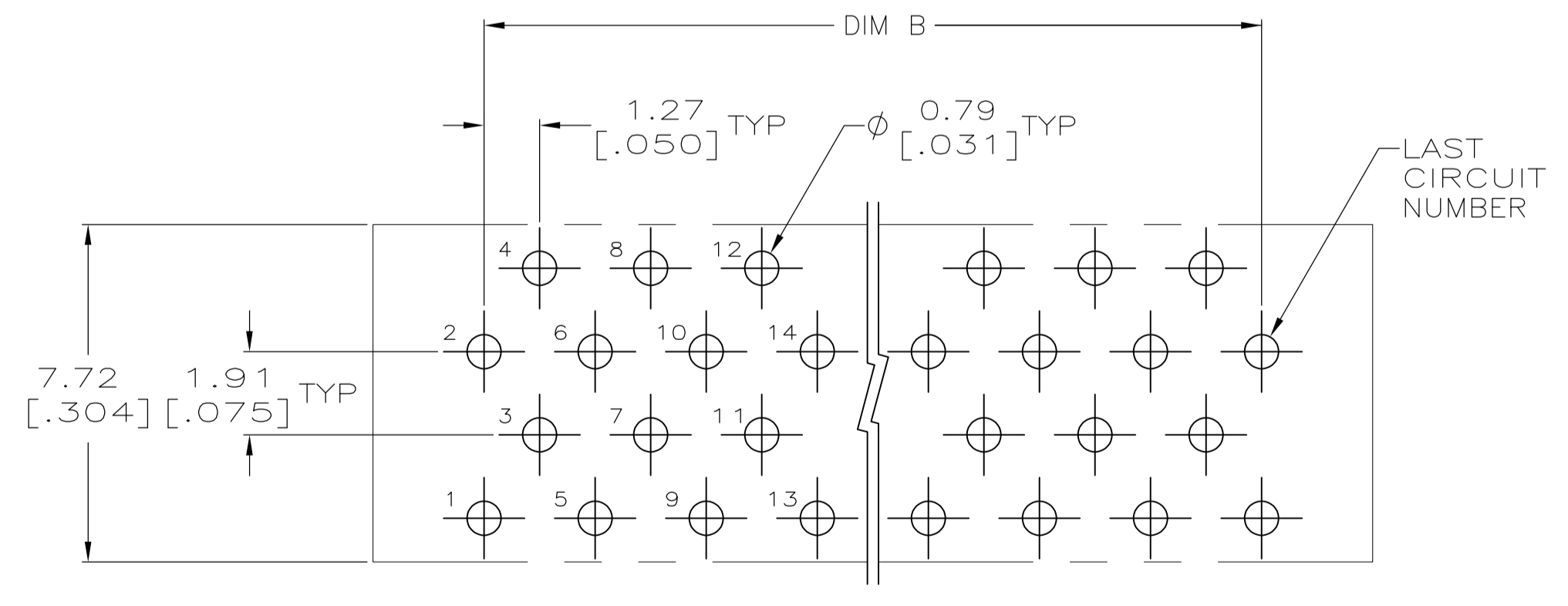

PRINTED CIRCUIT BOARD HOLE LAYOUT #1

THIS DRAWING IS A CONTROLLED DOCUMENT. DIMENSIONING AND TOLERANCING PER ASME Y14.5M-2009		DIN G. ATTADIA 26NOV04	TE Connectivity																		
DIMENSIONS: mm [INCHES]		CIR C. ROHDE 26NOV04																			
TOLERANCES UNLESS OTHERWISE SPECIFIED:		APPD M. WALMSLEY 26NOV04	NAME AMPMODU SYSTEM 50, CONNECTOR, PADDLEBOARD																		
<table border="1"> <tr> <td>0 PL</td> <td>±</td> <td>-</td> </tr> <tr> <td>1 PL</td> <td>±</td> <td>-</td> </tr> <tr> <td>2 PL</td> <td>±</td> <td>-</td> </tr> <tr> <td>3 PL</td> <td>±</td> <td>-</td> </tr> <tr> <td>4 PL</td> <td>±</td> <td>-</td> </tr> <tr> <td>ANGLES</td> <td>±</td> <td>±</td> </tr> </table>		0 PL	±	-	1 PL	±	-	2 PL	±	-	3 PL	±	-	4 PL	±	-	ANGLES	±	±	PRODUCT SPEC	APPLICATION SPEC
0 PL	±	-																			
1 PL	±	-																			
2 PL	±	-																			
3 PL	±	-																			
4 PL	±	-																			
ANGLES	±	±																			
MATERIAL SEE SHEET 1	FINISH SEE SHEET 1	WEIGHT -	SIZE A1																		
CUSTOMER DRAWING		SCALE 10:1	RESTRICTED TO																		