

# SPECIFICATIONS

PARAMETERS	VALUES	UNITS
RATED VOLTAGE	10	Vp-p
OPERATING VOLTAGE RANGE	1 ~ 50	Vp-p
RATED CURRENT (MAX)	11	mA
CAPACITANCE	18,000 ± 30%	pF
MINIMUM SPL @ 10 CM	97	dBA
RESONANT FREQUENCY	4,500 ± 500	Hz
OPERATING TEMPERATURE	-30 ~ +85	°C
STORAGE TEMPERATURE	-40 ~ +95	°C
HOUSING MATERIAL	UL94 ABS	-
TERMINAL MATERIAL	LEAD WIRE	-
WEIGHT	4.7	grams

THIS DOCUMENT CONTAINS DATA PROPRIETARY TO PROJECTS UNLIMITED, INC. ANY USE OR REPRODUCTION, IN ANY FORM, WITHOUT PRIOR WRITTEN PERMISSION OF PROJECTS UNLIMITED, INC. IS PROHIBITED.  
©2003, Projects Unlimited Inc.

# REVISION HISTORY

LTR	DESCRIPTION	DATE	APPROVED
-	RELEASED FROM ENGINEERING	8/9/2006	
A	REVISED TO INVENTOR 3-D DRAWING TEMPLATE	8/22/2008	B.R.
B	REVISED WEIGHT	2/27/2020	M.V.

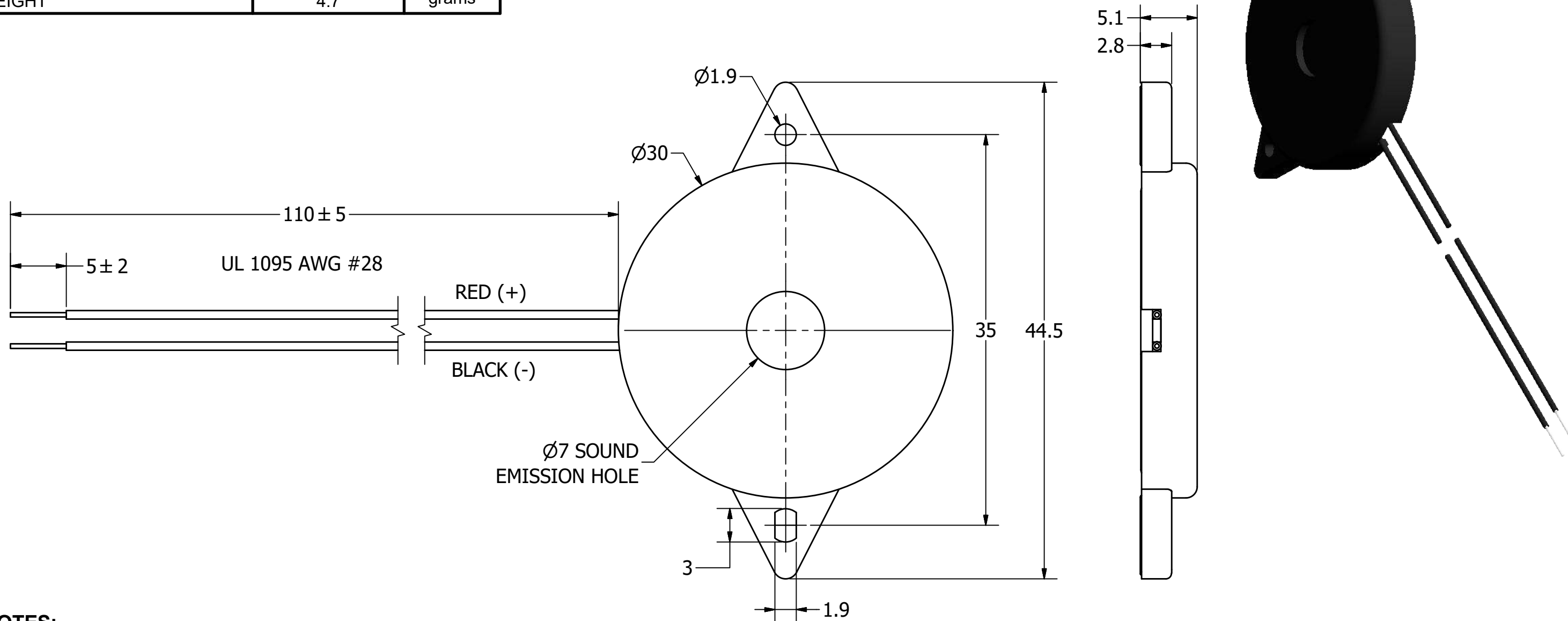

## NOTES:

1. ALL DIMENSIONS ARE IN MILLIMETERS.
2. SPECIFICATIONS SUBJECT TO CHANGE OR WITHDRAWL WITHOUT NOTICE.
3. THIS PART IS RoHS 2002/95/EC COMPLIANT.

UNLESS OTHERWISE SPECIFIED: DIMENSIONS ARE IN MILLIMETERS, TOLERANCES ARE ±0.5 AND ANGLES ARE ±3°.	SIZE <b>A3</b>	Designed by	Date	Checked by	Date	Approved by	Date	Drawn Date
		J.D.	7/31/2006	E.P.	8/9/2006	R.W.	8/9/2006	8/22/2008
AT-3045-TF-LW110-R.idw				<b>AT-3045-TF-LW110-R</b> Transducer (Piezo)		Edition	Sheet	
						-	1 / 1	