

WITH MOUNTING CLIPS

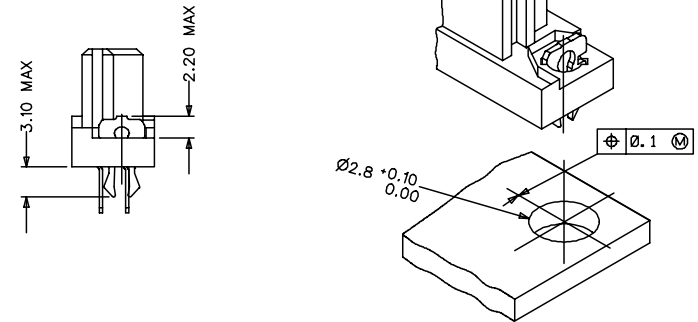

RECOMMENDED PCB LAYOUT  
COMPONENT SIDE

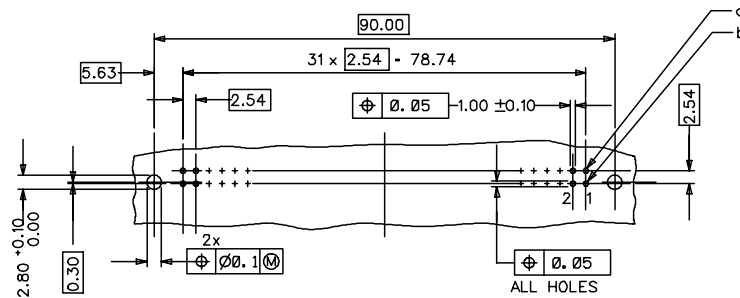

NOTES:



- 1) MATERIALS: THERMOPLASTIC POLYESTER, GLASS FILLED, UL94V-0. COLOUR: NATURAL  
TERMINAL - PHOSPHOR BRONZE  
MOUNTING CLIP: STEEL
- 2) FINISH: TERMINAL:-  
CONTACT AREA
  1. PERFORMANCE LEVEL 1: SELECTIVE GOLD (Au), THICKNESS = 1.1 MICROMETER  
OVER NICKEL, THICKNESS = 1.8 MICROMETER
  2. PERFORMANCE LEVEL 2: SELECTIVE GOLD (Au), THICKNESS = 0.6 MICROMETER  
OVER NICKEL, THICKNESS = 1.8 MICROMETER
  3. PERFORMANCE LEVEL 3: SELECTIVE GOLD (Au), THICKNESS = 0.3 MICROMETER  
OVER NICKEL, THICKNESS = 1.8 MICROMETER
 TERMINATION AREA:  
SELECTIVE TIN, THICKNESS = 5 MICROMETER  
OVER NICKEL, THICKNESS = 1.5 MICROMETER OVERALL
- 3) MOUNTING CLIP:-  
TIN (Sn), THICKNESS = 5-10 MICROMETER,  
OVER NICKEL (Ni), THICKNESS = 2.5 MICROMETER
- 4) FOR NON MOUNTING CLIP OPTION, CONNECTOR TO BE SECURED WITH  
RIVETS: 2 TUBULAR RIVETS 2.5 x 0.3 ... DIN 7340  
SCREWS: 2 CHEESEHEAD SCREWS M2.5 x .... DIN 84 AND 2 HEXAGONAL NUTS M2.5 DIN 934
- 5) MATERIAL NUMBER, BATCH CODE, UL AND CSA MARKING  
TO BE PRINTED ON THE CONNECTOR
- 6) CUT FACE OF TIP WITHOUT PLATING PERMITTED

RoHS COMPLIANT

ENTER DESCRIPTION E.C.N.C. 12007.0044, 2006/10/10 DRAWN BY: SIVAKUMAR 2005/01/27 CHECKED BY: SSUDHIR 2005/01/27 APPROVED BY: SSUDHIR 2005/01/27	QUALITY SYMBOLS ▽=0 ▽=0	GENERAL TOLERANCES (UNLESS SPECIFIED)		DIMENSION STYLE MM ONLY		SCALE ---	DESIGN UNITS METRIC	THIRD ANGLE PROJECTION
		mm	INCH	DRAWN BY SIVAKUMAR	DATE 2005/01/27	TITLE ASSY, DIN 41612 B FEMALE, 64 POS ROHS COMPLIANT PART		
DRAFT WHERE APPLICABLE MUST REMAIN WITHIN DIMENSIONS	SIZE A1	4 PLACES ± 0.15		APPROVED BY SSUDHIR		DATE 2005/01/27		MATERIAL NO. SD-36505-007
		3 PLACES ± 0.05		DATE 2005/01/27		DOCUMENT NO. SD-36505-007	SHEET NO. 1 OF 2	
		2 PLACES ± 0.1						
		1 PLACE ± 0.15						
		ANGULAR ± 2°						

20	19	18	17	16	15	14	13	12	11	10	9	8	7	6	5	4	3	2	1
MATERIAL No	MOLEX ENG No	PERF LEVEL	PLATING	CONTACT SEQUENCE/ROW	DIM "L" mm	MOUNTING CLIP	FLUX PROOF												
36505-0289	-	2	Au+Ni	1.2.3....32 a+b	2.9	YES	NO												

RoHS COMPLIANT

<b>ENTER DESCRIPTION</b> ELC.NCL.12007.0044 DRWNGSATTI/MARAD 2006/10/10 CHKD/SSUDHIR 2006/10/11 APPR/SSUDHIR 2006/10/16 <b>A1</b>	<b>QUALITY SYMBOLS</b>  	<b>GENERAL TOLERANCES (UNLESS SPECIFIED)</b>		<b>MM ONLY</b>	<b>SCALE</b> ---	<b>DESIGN UNITS</b> METRIC	 <b>THIRD ANGLE PROJECTION</b>		
		4 PLACES ± --- ± ---	INCH	DRAWN BY SIVAKUMAR	DATE 2005/01/27	<b>TITLE</b> ASSY, DIN 41612 B FEMALE, 64 POS ROHS COMPLAINT PART			
		3 PLACES ± 0.05 ± ---		CHECKED BY SSUDHIR	DATE 2005/01/27	<b>MATERIAL NO.</b> SEE CHART			
		2 PLACES ± 0.1 ± --- 1 PLACE ± 0.15 ± --- ANGULAR ± ---°		APPROVED BY SSUDHIR	DATE 2005/01/27	<b>DOCUMENT NO.</b> SD-36505-007	<b>SHEET NO.</b> 2 OF 2		