

ELESA original design CFG.



Metric table

Dimensions in: millimeters - inches

¹ l ₁	² m ₁	³ m ₂	d ₁	d ₂	h ₁	h ₂	l ₂	l ₃	For profile width s ₁ - s ₂
54 2.13	17.5 0.69	17.5 0.69	6.5 0.26	8 0.31	16 0.63	8 0.31	36 1.42	27 1.06	30 - 30 1.18 - 1.18
64 2.52	17.5 0.69	22.5 0.89	6.5 0.26	8 0.31	16 0.63	8 0.31	36 1.42	27 1.06	30 - 40 1.18 - 1.57
69 2.72	17.5 0.69	25 0.98	6.5 0.26	8 0.31	16 0.63	8 0.31	36 1.42	27 1.06	30 - 45 1.18 - 1.77
84 3.31	17.5 0.69	32.5 1.28	6.5 0.26	8 0.31	16 0.63	8 0.31	36 1.42	27 1.06	30 - 60 1.18 - 2.36
74 2.91	22.5 0.89	22.5 0.89	6.5 0.26	8 0.31	16 0.63	8 0.31	36 1.42	37 1.46	40 - 40 1.57 - 1.57
79 3.11	22.5 0.89	25 0.98	6.5 0.26	8 0.31	16 0.63	8 0.31	36 1.42	37 1.46	40 - 45 1.57 - 1.77
94 3.70	22.5 0.89	32.5 1.28	6.5 0.26	8 0.31	16 0.63	8 0.31	36 1.42	37 1.46	40 - 60 1.57 - 2.36
84 3.31	25 0.98	25 0.98	6.5 0.26	8 0.31	16 0.63	8 0.31	36 1.42	42 1.65	45 - 45 1.77 - 1.77
99 3.90	25 0.98	32.5 1.28	6.5 0.26	8 0.31	16 0.63	8 0.31	36 1.42	42 1.65	45 - 60 1.77 - 2.36
114 4.49	32.5 1.28	32.5 1.28	6.5 0.26	8 0.31	16 0.63	8 0.31	36 1.42	57 2.24	60 - 60 2.36 - 2.36

Specification

- Body
Plastic
Technopolymer (Polyamide PA)
- Black, matte finish ● **SW**
- Gray, matte finish ○ **LG**
- Temperature resistant up to 265 °F (130 °C)
- Pin
Steel, nickel plated
- **RoHS compliant**

Information

EN 159 hinges are suitable for simple installation on standard commercially available T-slot aluminum profile extrusions. They will support the weight of a door by utilizing the provided rectangular positioning elements. These are simply clipped into recesses in the hinge wings. They will fit 8 mm and 10 mm wide grooves.

see also...

- *List of Hinge Types*
- *Hinges GN 161 (Zinc Die-Cast, for Aluminum Profiles)*
- *Double Hinges EN 159.1 (Technopolymer Plastic, for Profile Systems)*
- *T-Nut Assemblies GN 965 (for 30 / 40 Aluminum T-Slot Profile Systems)*
- *T-Nut Assemblies GN 968 (for 30 / 40 / 45 Aluminum T-Slot Profile Systems)*

How to order

¹ ² ³ ⁴
EN 159-84-17.5-32.5-SW

¹	Width l₁
²	Bore distance m₁
³	Bore distance m₂
⁴	Color



Positioning elements

Application example

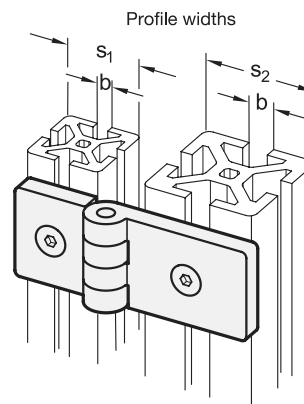
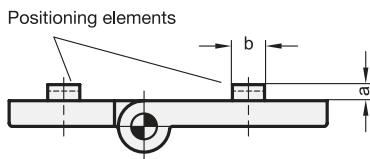

Profile width	b Groove width	a
30 <i>1.18</i>	6 <i>0.24</i>	2 <i>0.08</i>
30 <i>1.18</i>	8 <i>0.31</i>	2 <i>0.08</i>
40 - 45 <i>1.57 - 1.77</i>	8 <i>0.31</i>	4 <i>0.16</i>
40 - 45 <i>1.57 - 1.77</i>	10 <i>0.39</i>	4 <i>0.16</i>
60 <i>2.36</i>	10 <i>0.39</i>	5 <i>0.20</i>
60 <i>2.36</i>	12 <i>0.47</i>	5 <i>0.20</i>

The positioning elements are clipped into the corresponding recesses of the hinge wing.

