

THIS DRAWING IS UNPUBLISHED. RELEASED FOR PUBLICATION 2011
 © COPYRIGHT 2011 ALL RIGHTS RESERVED.

LOC	DIST	REVISIONS					
		P	LTR	DESCRIPTION	DATE	DWN	APVD
AI	-		B1	DIM "B" ADDED	05DEC2014	PS	JK

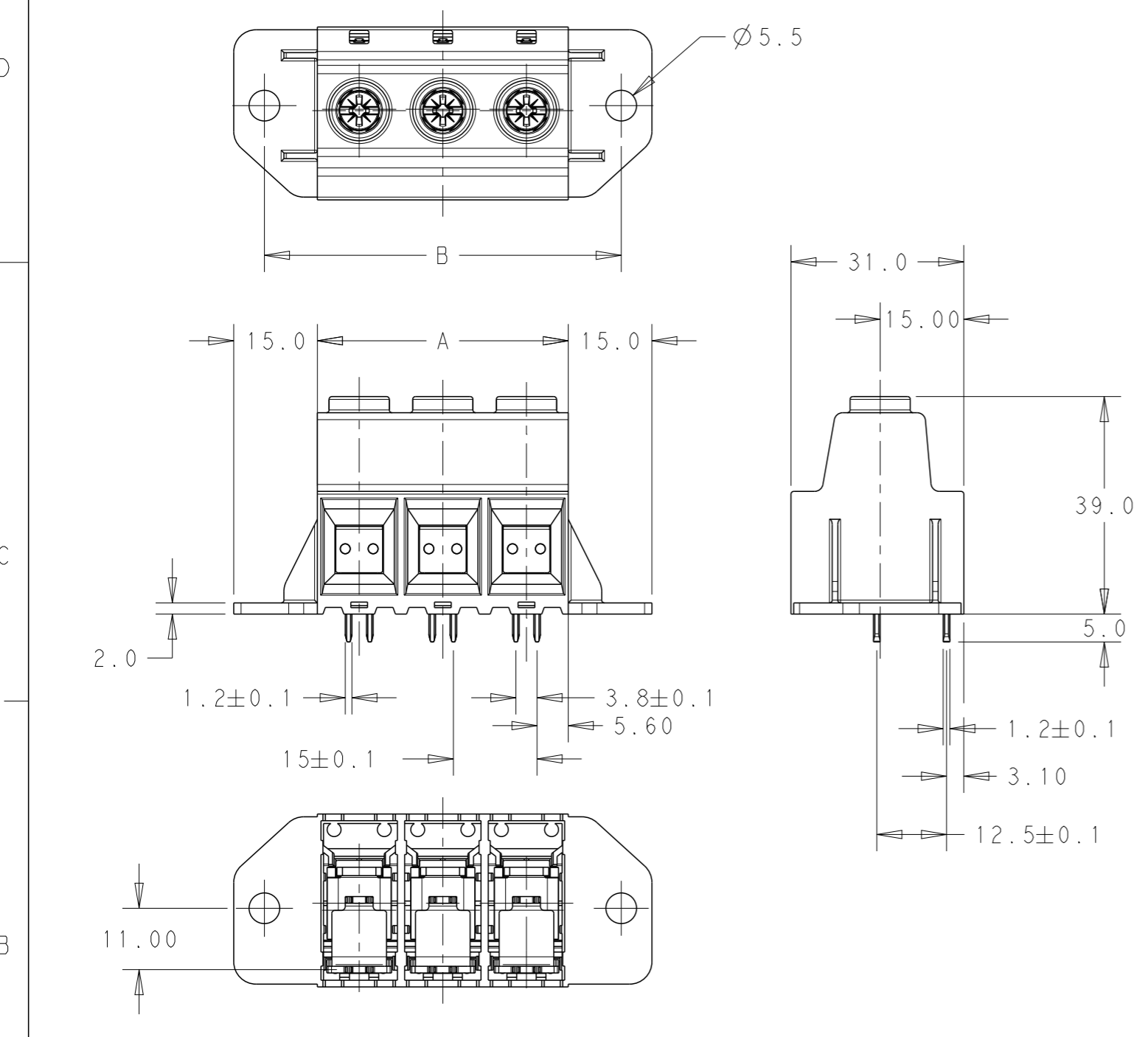

- NOTES:
- MATERIALS:**
 HOUSING-PA66, UL94 VO, COLOR-GREEN
 SCREW- M5, STEEL, NICKEL PLATED
 CLAMP- STEEL, NICKEL PLATED
 CONTACT PIN- BRASS, TIN PLATED
 - MECHANICAL:**
 PCB THICKNESS-2.40 MAX
 PCB HOLE DIAMETER-1.60 MIN
 STRIP LENGTH-18 mm
 OPERATING TEMPERATURE:-40°C TO +110°C
 RECOMMENDED/HIGHEST TIGHTENING TORQUE-2.1/2.5 Nm.
 - ELECTRICAL:**
 WIRE RANGE- 20 TO 1 AWG
 VOLTAGE RATING- 600 VOLTS
 CURRENT RATING-130 A FIELD WIRING;135A FACTORY WIRING
 CONTACT RESISTANCE-15 mOHM MAX
 INSULATION RESISTANCE-10⁹ OHMS MIN (500V DC)

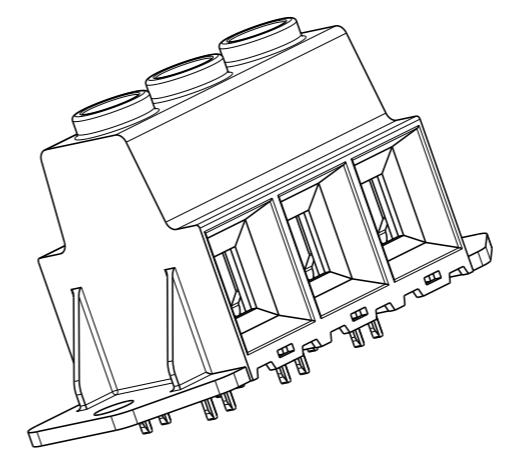

SCALE 1:1
 -3 AS SHOWN

DIM "B"	DIM "A"	POLE	PART NUMBER
199.00	180.00	12	1-1986715-2
184.00	165.00	11	1-1986715-1
169.00	150.00	10	1-1986715-0
154.00	135.00	9	1986715-9
139.00	120.00	8	1986715-8
124.00	105.00	7	1986715-7
109.00	90.00	6	1986715-6
94.00	75.00	5	1986715-5
79.00	60.00	4	1986715-4
64.00	45.00	3	1986715-3
49.00	30.00	2	1986715-2

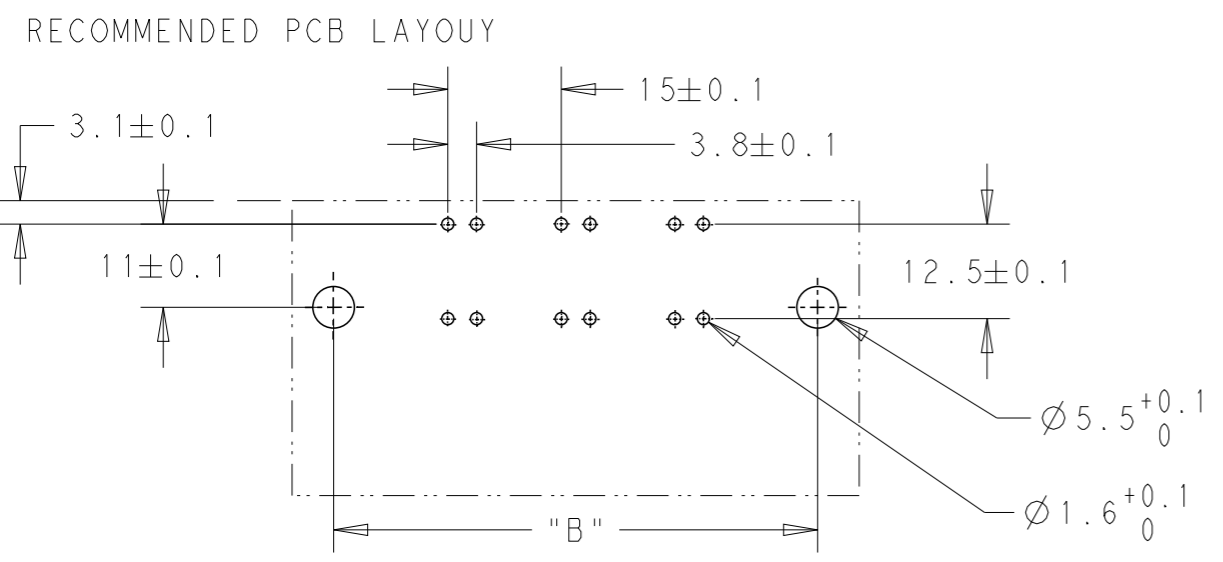

THIS DRAWING IS A CONTROLLED DOCUMENT.		DWN 13SEP2011 RAGHAVENDRA	TE Connectivity	
DIMENSIONS: mm		CHK 13SEP2011 SARVER MICHAEL		
TOLERANCES UNLESS OTHERWISE SPECIFIED:		APVD 13SEP2011 SARVER MICHAEL	NAME POWER TERMINAL BLOCK, DOUBLE PIN MOUNTING FLANGES; PITCH 15.00 mm	
0 PLC ±- 1 PLC ±0.25 2 PLC ±0.20 3 PLC ±- 4 PLC ±- ANGLES ±1°		PRODUCT SPEC -	SIZE CAGE CODE DRAWING NO RESTRICTED TO	
MATERIAL -		FINISH -	A300779 C-1986715	
		Customer Drawing	SCALE 1:1	SHEET 1 OF 1 REV B1