

Description

The AP7370 series is a positive voltage regulator IC.

The AP7370 has features of wide input voltage range, high accuracy, low dropout voltage, current limit, reverse current protection, and ultra-low quiescent current which make it ideal for use in various USB and portable devices and instrument application.

The IC consists of a voltage reference, an error amplifier, a resistor network for setting output voltage, a current limit circuit for current protection, and a chip enable circuit.

The AP7370 is available in 1.2V, 1.5V, 1.8V, 2.8V, 3.0V, 3.3V, 3.6V and 5.0V fixed output voltage versions.

The AP7370 is available in space-saving SOT23, SOT25, SOT89 and U-DFN2020-6 (Type C) packages.

Features

- Wide Input Voltage Range: Up to 18V
- Low Dropout Voltage: $V_{DROP} = 500mV @ I_{OUT} = 100mA$
- Low Ground Current
- High Output Voltage Accuracy
- Compatible with Low ESR Ceramic Capacitor
- Excellent Line/Load Regulation
- Thermal Shutdown Function
- Short Current Protection
- Reverse Current Protection
- **Totally Lead-Free & Fully RoHS Compliant (Notes 1 & 2)**
- **Halogen and Antimony Free. "Green" Device (Note 3)**

Applications

- Battery-Powered Equipment
- Laptop, Palmtops, Notebook Computers
- Portable Information Appliances
- Metering
- Weighing Scales

- Notes:
1. No purposely added lead. Fully EU Directive 2002/95/EC (RoHS), 2011/65/EU (RoHS 2) & 2015/863/EU (RoHS 3) compliant.
 2. See <https://www.diodes.com/quality/lead-free/> for more information about Diodes Incorporated's definitions of Halogen- and Antimony-free, "Green" and Lead-free.
 3. Halogen- and Antimony-free "Green" products are defined as those which contain <900ppm bromine, <900ppm chlorine (<1500ppm total Br + Cl) and <1000ppm antimony compounds.

Pin Assignments

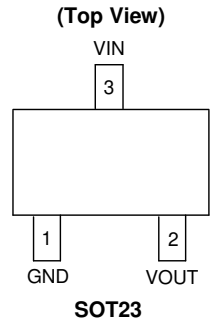
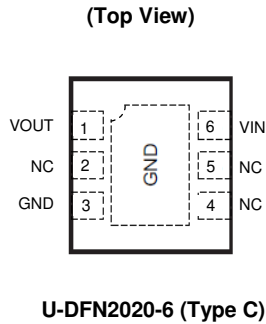
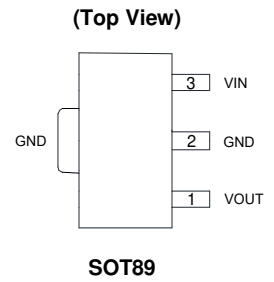
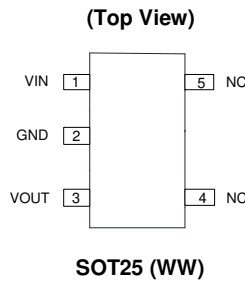
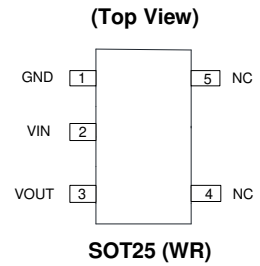
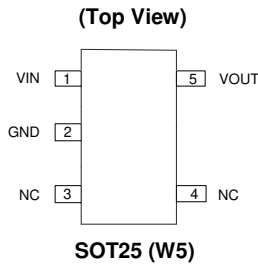

Typical Applications Circuit

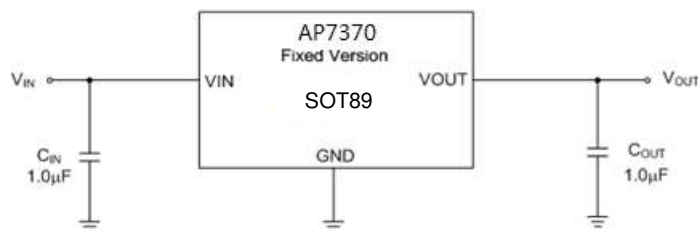

Pin Descriptions

Pin Number						Pin Name	Function
SOT25 (W5)	SOT25 (WR)	SOT25 (WW)	SOT89	SOT23	U-DFN2020-6 (Type C)		
1	2	1	3	3	6	VIN	Input voltage
2	1	2	2	1	3	GND	Ground
3, 4	4, 5	4, 5	—	—	2, 4, 5	NC	Not connected for fixed version
5	3	3	1	2	1	VOUT	Regulated output voltage
—	—	—	—	—	EP	GND	Ground

Absolute Maximum Ratings

Symbol	Parameter	Rating		Unit
V _{IN}	Supply Input Voltage	20		V
I _{OUT}	Output Current	500		mA
T _{LEAD}	Lead Temperature (Soldering, 10s)	+260		°C
T _J	Operating Junction Temperature	+150		°C
θ _{JA}	Thermal Resistance (Junction to Ambient)	SOT23	205	°C/W
		SOT25	155	
		SOT89	126	
		U-DFN2020-6 (Type C)	54	
θ _{JC}	Thermal Resistance (Junction to Case)	SOT23	37	°C/W
		SOT25	23	
		SOT89	26	
		U-DFN2020-6 (Type C)	9.5	
T _{STG}	Storage Temperature Range	-65 to +150		°C
—	ESD (Change Device Model)	1500		V
—	ESD (Human Body Model)	6000		V

Recommended Operating Conditions

Symbol	Parameter	Min	Max	Unit
V _{IN}	Supply Input Voltage	3.2	18	V
T _J	Operating Junction Temperature	-40	+125	°C

Electrical Characteristics (@ $T_A = -40^{\circ}\text{C}$ to $+85^{\circ}\text{C}$, $V_{IN} = V_{OUT(Typ)} + 1\text{V}$ or 2.7V (whichever is greater), $I_{OUT} = 10\text{mA}$, and $C_{IN} = C_{OUT} = 1.0\mu\text{F}$ ceramic, unless otherwise noted. Typical values are at $T_A = +25^{\circ}\text{C}$.)

Symbol	Parameter	Test Conditions	Min	Typ	Max	Unit
V_{OUT}	Output Voltage	$V_{OUT} > 2.5\text{V}$	$V_{OUT} \times 99\%$	V_{OUT}	$V_{OUT} \times 101\%$	V
		$V_{OUT} \leq 2.5\text{V}$	$V_{OUT} \times 98\%$	V_{OUT}	$V_{OUT} \times 102\%$	V
V_{IN}	Input Voltage	—	3.2	—	18	V
I_{LIMIT}	Current Limit (Note 4)	$V_{OUT} > 2.5\text{V}$, $V_{OUT1} = 98\% \times V_{OUT}$	350	—	—	mA
		$V_{OUT} \leq 2.5\text{V}$, $V_{OUT1} = 98\% \times V_{OUT}$	200	—	—	mA
$\Delta V_{OUT}/\Delta V_{IN}/V_{OUT}$	Line Regulation	$(V_{OUT(Nom)} + 1\text{V}, 3.2\text{V}) \leq V_{IN} \leq 18\text{V}$, $I_{OUT} = 10\text{mA}$	—	0.05	—	%/V
$\Delta V_{OUT}/V_{OUT}$	Load Regulation	$V_{OUT} > 2.5\text{V}$, $V_{IN} = V_{OUT} + 2\text{V}$, $1\text{mA} \leq I_{OUT} \leq 300\text{mA}$	—	0.5	—	%
		$V_{OUT} \leq 2.5\text{V}$, $V_{IN} = V_{OUT} + 3\text{V}$, $1\text{mA} \leq I_{OUT} \leq 150\text{mA}$	—	0.5	—	%
V_{DROP}	Dropout Voltage (Notes 5, 6)	$3.0\text{V} \leq V_{OUT} < 5.0\text{V}$ $I_{OUT} = 100\text{mA}$	—	500	600	mV
		$V_{OUT} = 5.0\text{V}$ $I_{OUT} = 100\text{mA}$	—	450	550	mV
I_{GND}	Ground Current	$I_{OUT} = 0\text{A}$	—	1.5	2.5	μA
		$V_{OUT} > 2.5\text{V}$, $I_{OUT} = 300\text{mA}$	—	250	300	
		$V_{OUT} \leq 2.5\text{V}$, $I_{OUT} = 150\text{mA}$	—	250	300	
$\Delta V_{OUT}/(V_{OUT} \times \Delta T)$	Output Voltage Temperature Coefficient	$I_{OUT} = 100\mu\text{A}$, $-40^{\circ}\text{C} \leq T_J \leq +125^{\circ}\text{C}$	—	± 100	—	ppm/ $^{\circ}\text{C}$
T_{OTSD}	Thermal Shutdown Temperature	—	—	+160	—	$^{\circ}\text{C}$
T_{HYOTSD}	Thermal Shutdown Hysteresis	—	—	+20	—	$^{\circ}\text{C}$

- Notes:
4. Measured with $V_{IN} = V_{OUT} + 3\text{V}$ for $V_{OUT} \leq 2.5\text{V}$. Measured with $V_{IN} = V_{OUT} + 2.5\text{V}$ for $V_{OUT} > 2.5\text{V}$.
 5. V_{DROP} is measured with $V_{IN} = 0.98 \times V_{OUT(Nom)}$.
 6. Dropout is only valid when $V_{OUT} \geq 2.8\text{V}$ because of the minimum input voltage limits.

Performance Characteristics

NEW PRODUCT

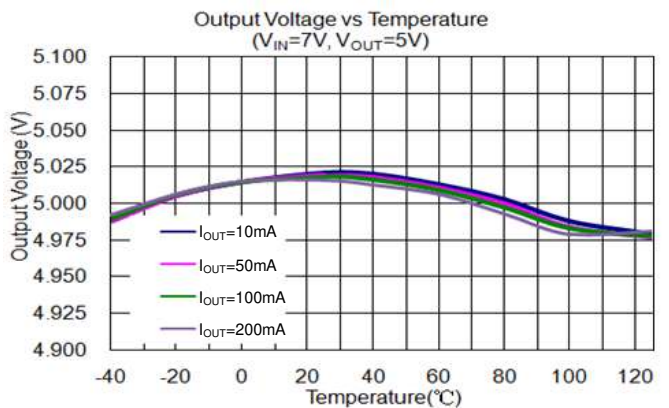
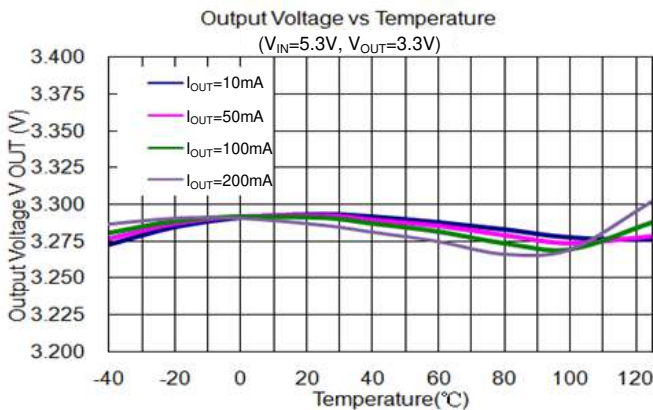
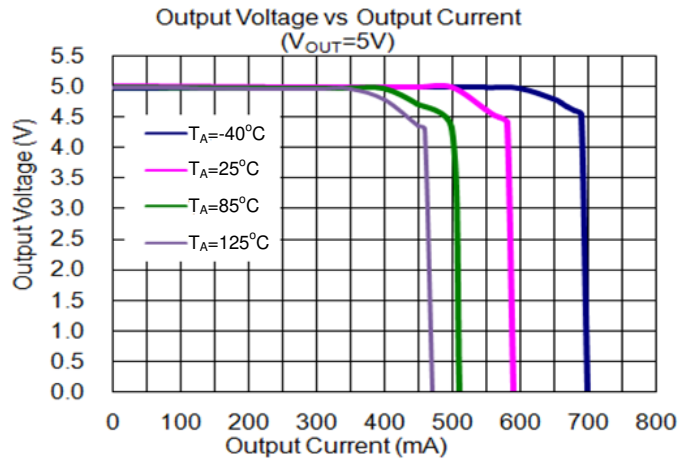
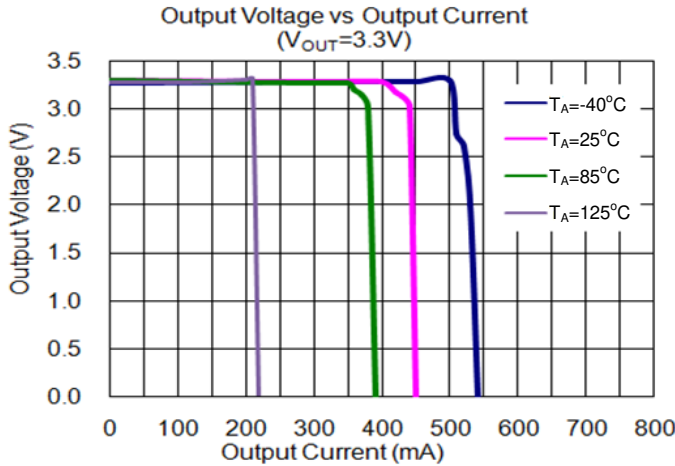
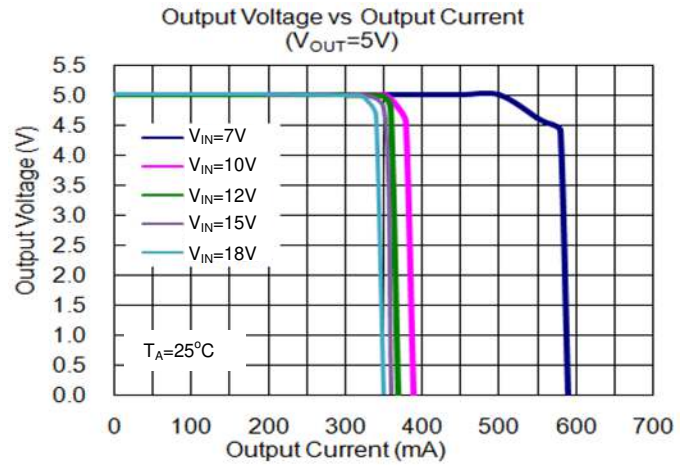
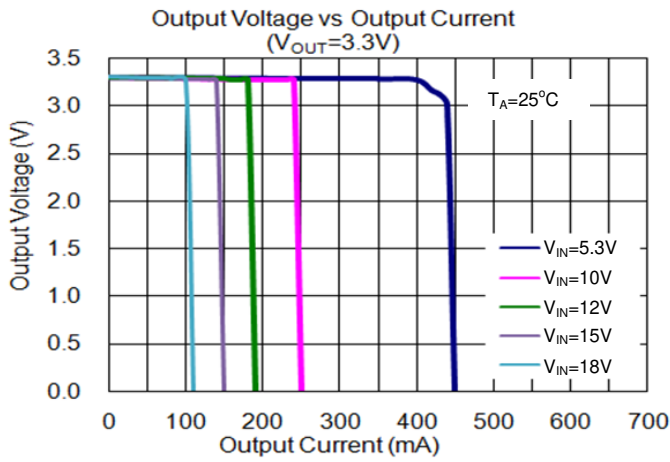

Performance Characteristics (continued)

NEW PRODUCT

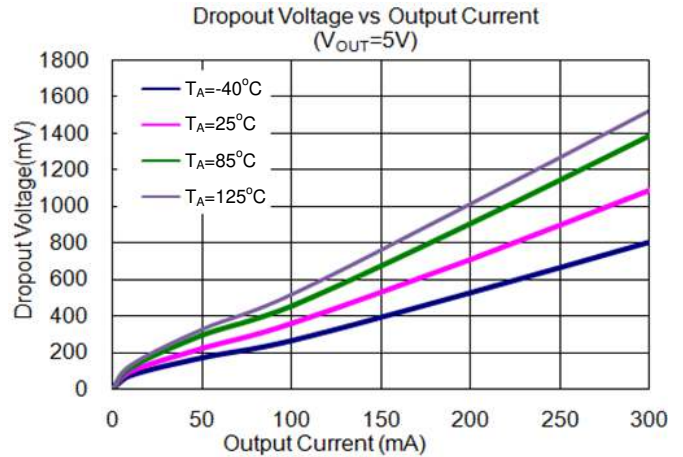
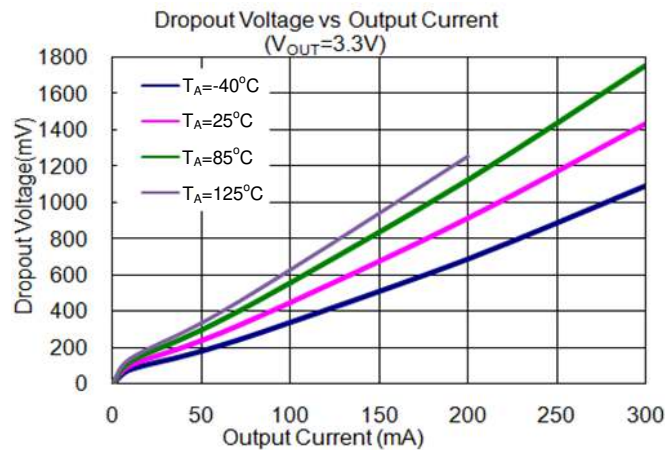
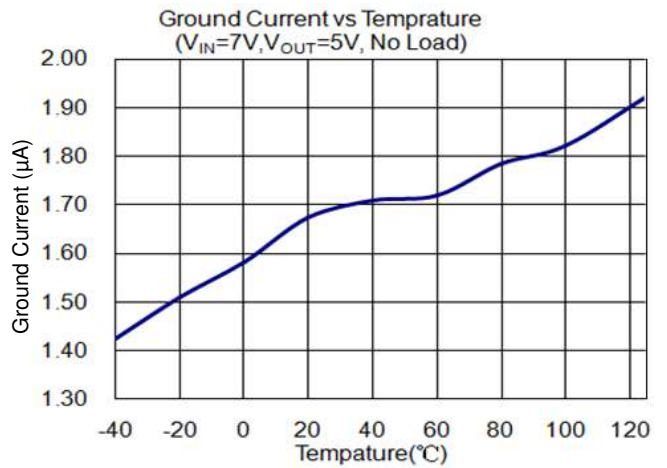
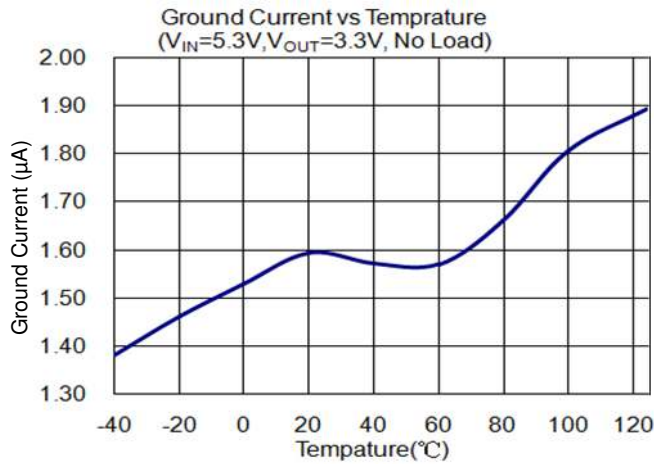
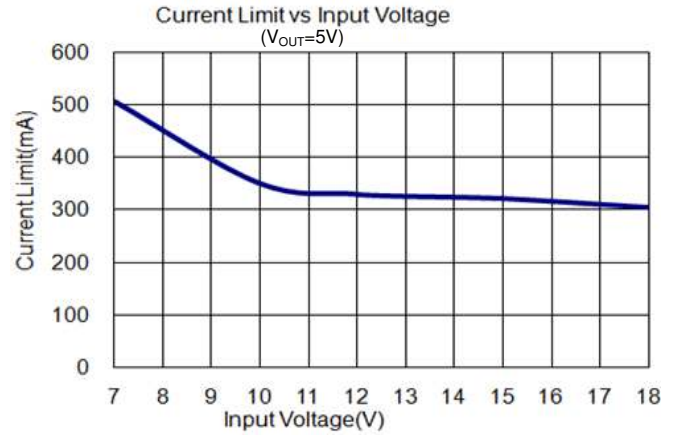
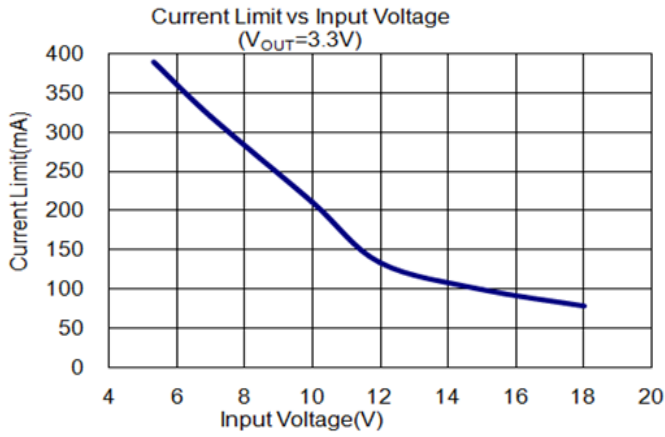

Performance Characteristics (continued)

NEW PRODUCT

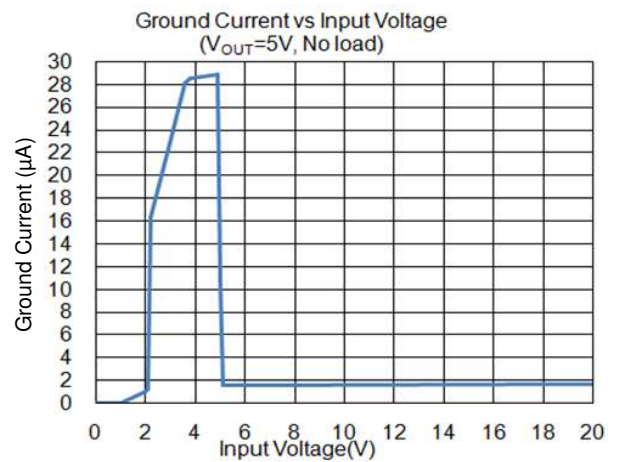
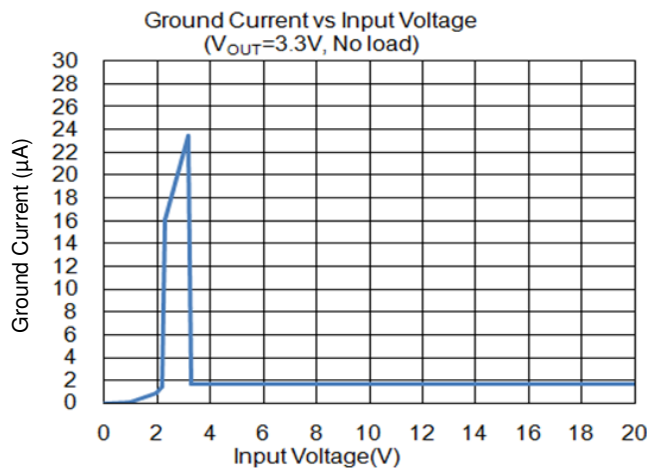
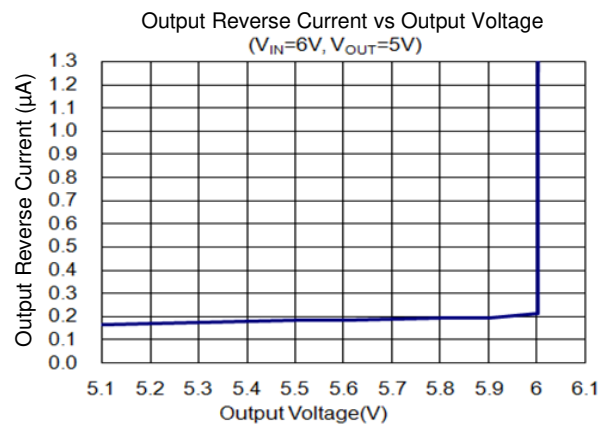
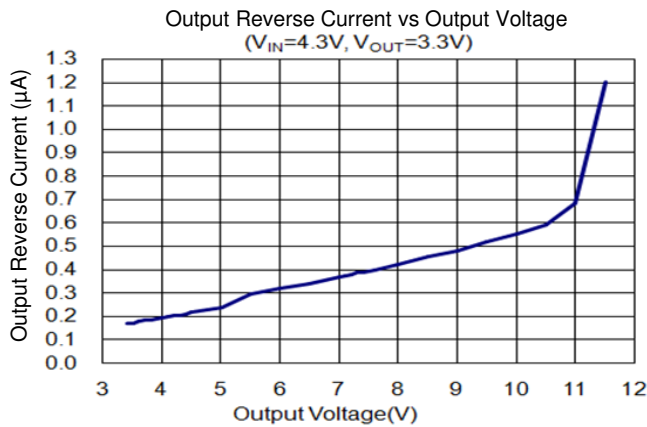
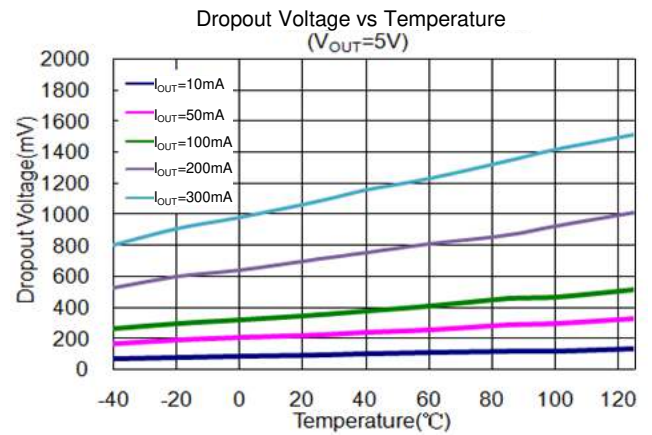
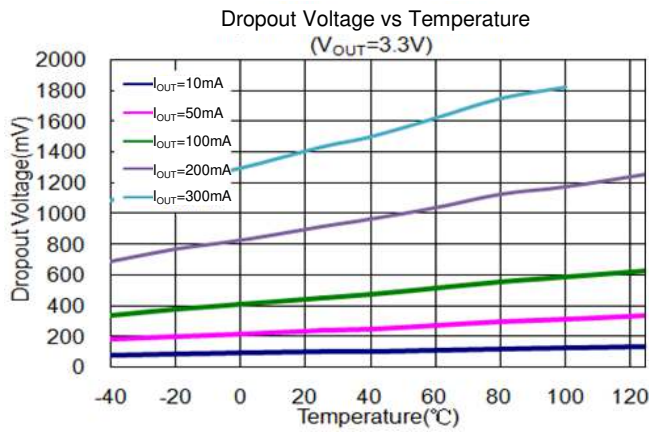

Performance Characteristics (continued)

NEW PRODUCT

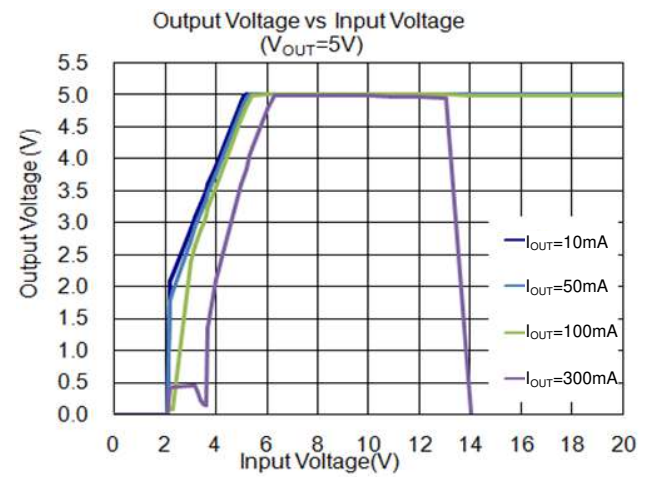
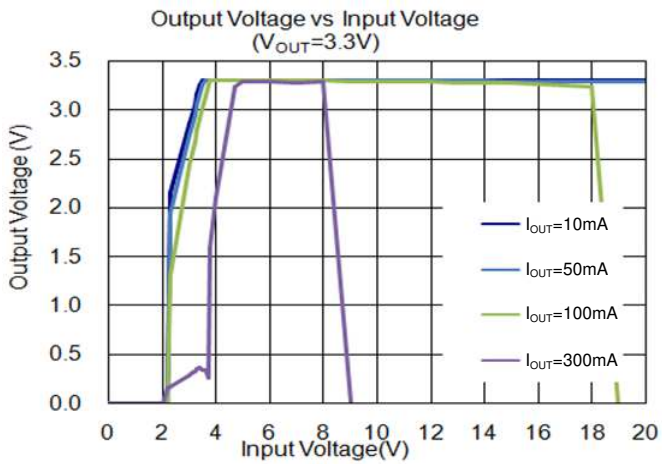
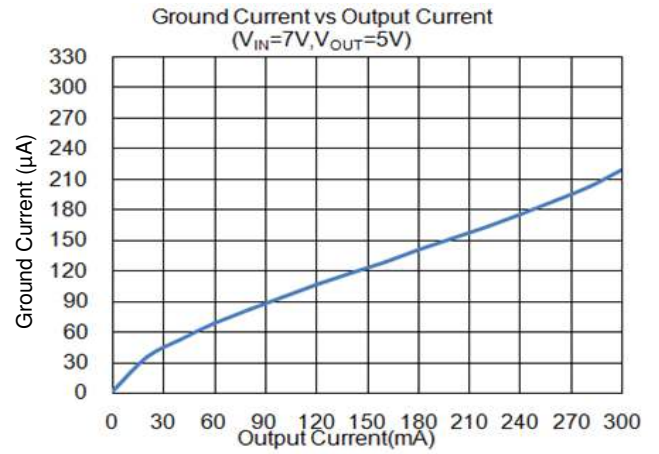
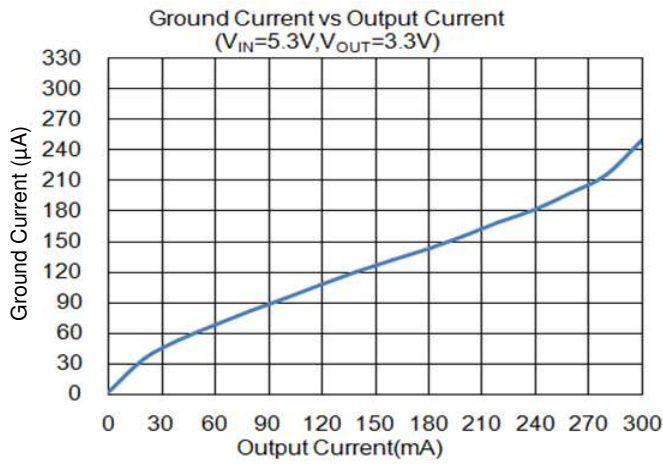

Load Transient
($V_{IN} = 5.3V, V_{OUT} = 3.3V, \text{Load} = 50\text{mA to } 100\text{mA}, T_A = +25^\circ\text{C}$)

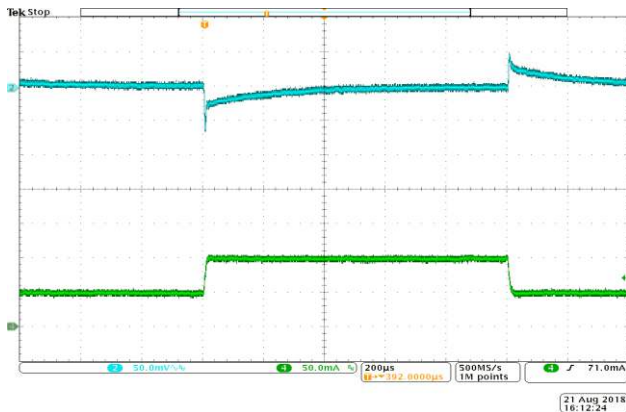

Load Transient
($V_{IN} = 7V, V_{OUT} = 5V, \text{Load} = 50\text{mA to } 100\text{mA}, T_A = +25^\circ\text{C}$)

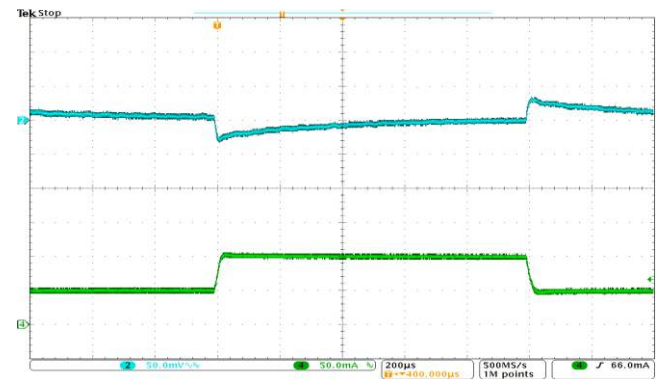

Performance Characteristics (continued)

Load Transient

$V_{IN} = 5.3V$, $V_{OUT} = 3.3V$, Load = 150mA to 300mA, $T_A = +25^\circ C$

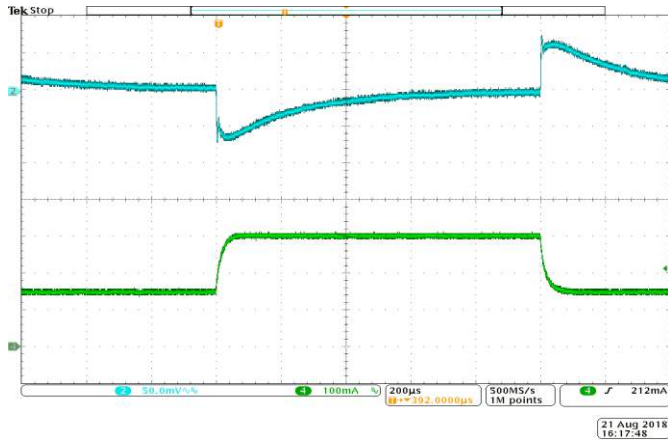

Load Transient

($V_{IN} = 7V$, $V_{OUT} = 5V$, Load = 150mA to 300mA, $T_A = +25^\circ C$)

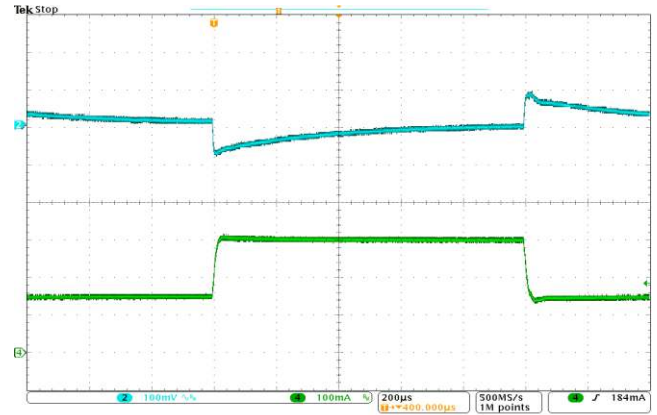

PSRR vs Frequency
($V_{IN} = 5.3V + AC0.5V_{P-P}$, $V_{OUT} = 3.3V$)

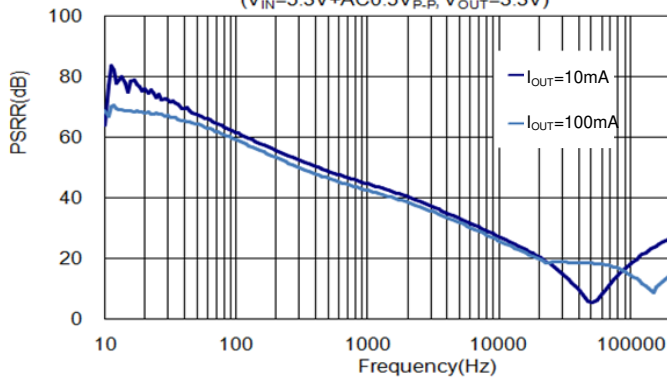

NEW PRODUCT

Ordering Information

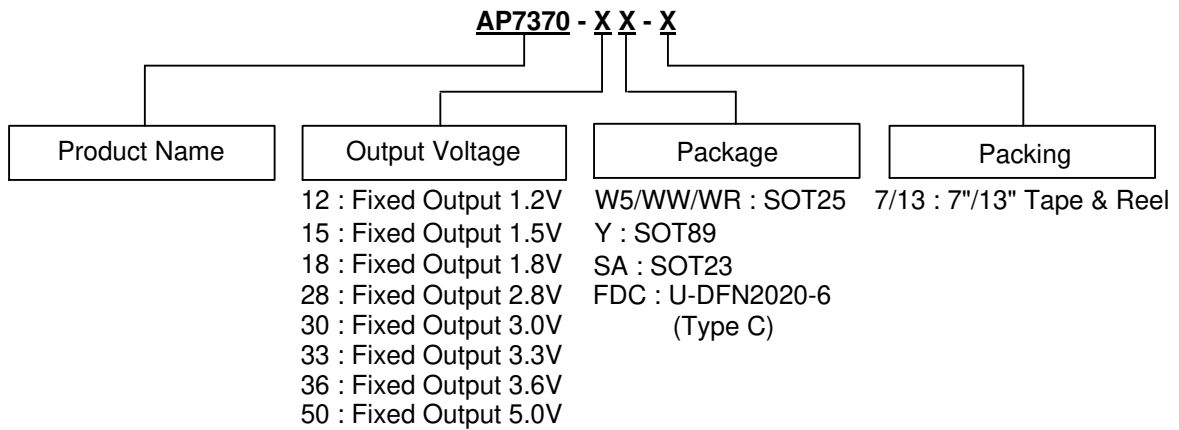

Part Number	Package Code	Package	7''/13'' Tape and Reel	
			Quantity	Part Number Suffix
AP7370-XXW5-7	W5	SOT25	3000/Tape & Reel	-7
AP7370-XXWR-7	WR	SOT25	3000/Tape & Reel	-7
AP7370-XXWW-7	WW	SOT25	3000/Tape & Reel	-7
AP7370-XXY-13	Y	SOT89	2500/Tape & Reel	-13
AP7370-XXSA-7	SA	SOT23	3000/Tape & Reel	-7
AP7370-XXFDC-7	FDC	U-DFN2020-6 (Type C)	3000/Tape & Reel	-7

NEW PRODUCT

Marking Information

(1) SOT25

(Top View)

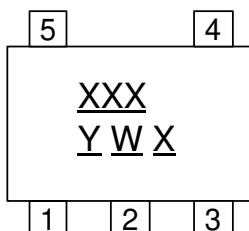

XXX : Identification Code

Y : Year 0 to 9

W : Week : A to Z : 1 to 26 week;
a to z : 27 to 52 week; z represents
52 and 53 week

X : Internal Code

Part Number	Package	Identification Code
AP7370-12W5-7	SOT25	B8A
AP7370-15W5-7	SOT25	B8F
AP7370-18W5-7	SOT25	B8B
AP7370-28W5-7	SOT25	B8G
AP7370-30W5-7	SOT25	B8C
AP7370-33W5-7	SOT25	B8D
AP7370-36W5-7	SOT25	B8E
AP7370-50W5-7	SOT25	B8H
AP7370-12WR-7	SOT25	B8J
AP7370-15WR-7	SOT25	B8R
AP7370-18WR-7	SOT25	B8K
AP7370-28WR-7	SOT25	B8S
AP7370-30WR-7	SOT25	B8M
AP7370-33WR-7	SOT25	B8N
AP7370-36WR-7	SOT25	B8P
AP7370-50WR-7	SOT25	B8T
AP7370-12WW-7	SOT25	B8U
AP7370-15WW-7	SOT25	B8Z
AP7370-18WW-7	SOT25	B8V
AP7370-28WW-7	SOT25	B82
AP7370-30WW-7	SOT25	B8W
AP7370-33WW-7	SOT25	B8X
AP7370-36WW-7	SOT25	B8Y
AP7370-50WW-7	SOT25	B83

Marking Information (continued)

(2) SOT89

(Top View)

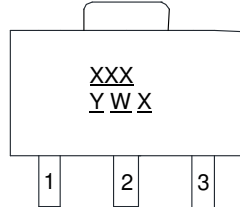

XXX : Identification Code
Y : Year : 0 ~ 9
W : Week : A ~ Z : 1 ~ 26 Week;
 a ~ z : 27 ~ 52 Week;
 z Represents 52 and 53 Week
X : Internal Code

Part Number	Package	Identification Code
AP7370-12Y-13	SOT89	B8A
AP7370-15Y-13	SOT89	B8F
AP7370-18Y-13	SOT89	B8B
AP7370-28Y-13	SOT89	B8G
AP7370-30Y-13	SOT89	B8C
AP7370-33Y-13	SOT89	B8D
AP7370-36Y-13	SOT89	B8E
AP7370-50Y-13	SOT89	B8H

(3) SOT23

(Top View)

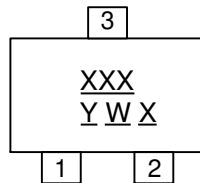

XXX : Identification Code
Y : Year 0 to 9
W : Week : A to Z : 1 to 26 week;
 a to z : 27 to 52 week; z represents
 52 and 53 week
X : Internal Code

Part Number	Package	Identification Code
AP7370-12SA-7	SOT23	B8J
AP7370-15SA-7	SOT23	B8R
AP7370-18SA-7	SOT23	B8K
AP7370-28SA-7	SOT23	B8S
AP7370-30SA-7	SOT23	B8M
AP7370-33SA-7	SOT23	B8N
AP7370-36SA-7	SOT23	B8P
AP7370-50SA-7	SOT23	B8T

Ordering Information (continued)

(4) U-DFN2020-6 (Type C)

(Top View)

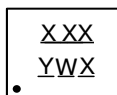

XXX : Identification Code
Y : Year : 0~9
W : Week : A~Z : 1~26 week;
 a~z : 27~52 week; z represents
 52 and 53 week
X : Internal Code

Device	Package	Identification Code
AP7370-12FDC-7	U-DFN2020-6 (Type C)	B8U
AP7370-15FDC-7	U-DFN2020-6 (Type C)	B8Z
AP7370-18FDC-7	U-DFN2020-6 (Type C)	B8V
AP7370-28FDC-7	U-DFN2020-6 (Type C)	B82
AP7370-30FDC-7	U-DFN2020-6 (Type C)	B8W
AP7370-33FDC-7	U-DFN2020-6 (Type C)	B8X
AP7370-36FDC-7	U-DFN2020-6 (Type C)	B8Y
AP7370-50FDC-7	U-DFN2020-6 (Type C)	B83

NEW PRODUCT

Package Outline Dimensions

Please see <http://www.diodes.com/package-outlines.html> for the latest version.

(1) Package Type: SOT23

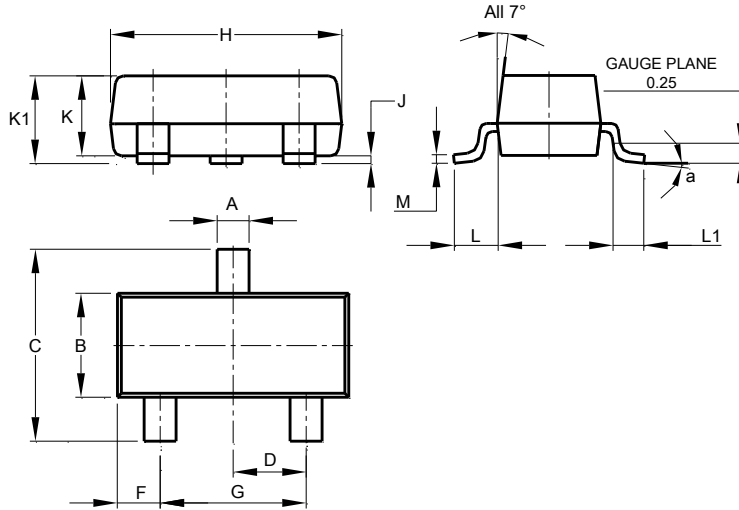

SOT23			
Dim	Min	Max	Typ
A	0.37	0.51	0.40
B	1.20	1.40	1.30
C	2.30	2.50	2.40
D	0.89	1.03	0.915
F	0.45	0.60	0.535
G	1.78	2.05	1.83
H	2.80	3.00	2.90
J	0.013	0.10	0.05
K	0.890	1.00	0.975
K1	0.903	1.10	1.025
L	0.45	0.61	0.55
L1	0.25	0.55	0.40
M	0.085	0.150	0.110
a	0°	8°	--
All Dimensions in mm			

(2) Package Type: SOT25

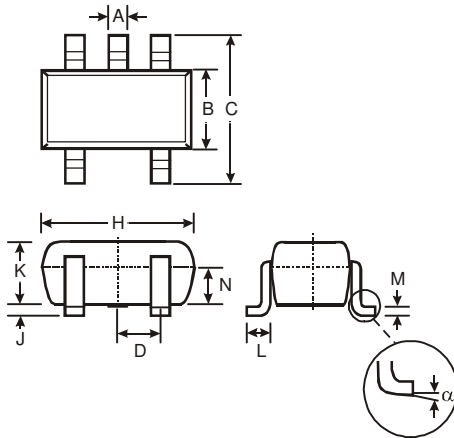

SOT25			
Dim	Min	Max	Typ
A	0.35	0.50	0.38
B	1.50	1.70	1.60
C	2.70	3.00	2.80
D	-	-	0.95
H	2.90	3.10	3.00
J	0.013	0.10	0.05
K	1.00	1.30	1.10
L	0.35	0.55	0.40
M	0.10	0.20	0.15
N	0.70	0.80	0.75
α	0°	8°	-
All Dimensions in mm			

NEW PRODUCT

Package Outline Dimensions (continued)

Please see <http://www.diodes.com/package-outlines.html> for the latest version.

(3) Package Type: SOT89

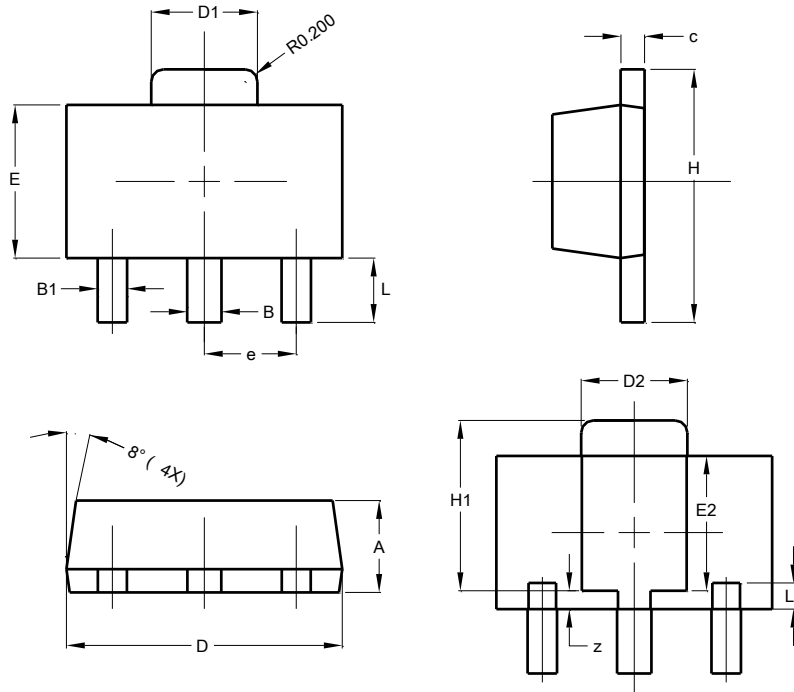

SOT89			
Dim	Min	Max	Typ
A	1.40	1.60	1.50
B	0.50	0.62	0.56
B1	0.42	0.54	0.48
c	0.35	0.43	0.38
D	4.40	4.60	4.50
D1	1.62	1.83	1.733
D2	1.61	1.81	1.71
E	2.40	2.60	2.50
E2	2.05	2.35	2.20
e	-	-	1.50
H	3.95	4.25	4.10
H1	2.63	2.93	2.78
L	0.90	1.20	1.05
L1	0.327	0.527	0.427
z	0.20	0.40	0.30
All Dimensions in mm			

(4) Package Type: U-DFN2020-6 (Type C)

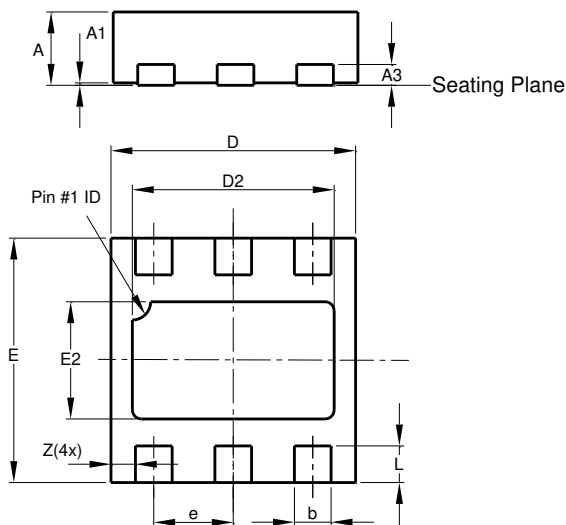

U-DFN2020-6 Type C			
Dim	Min	Max	Typ
A	0.57	0.63	0.60
A1	0.00	0.05	0.02
A3	—	—	0.15
b	0.25	0.35	0.30
D	1.95	2.075	2.00
D2	1.55	1.75	1.65
E	1.95	2.075	2.00
E2	0.86	1.06	0.96
e	—	—	0.65
L	0.25	0.35	0.30
Z	—	—	0.20
All Dimensions in mm			

NEW PRODUCT

Suggested Pad Layout

Please see <http://www.diodes.com/package-outlines.html> for the latest version.

(1) Package Type: SOT23

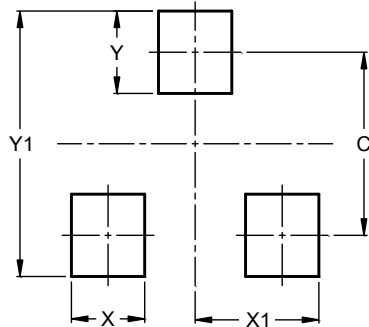

Dimensions	Value (in mm)
C	2.0
X	0.8
X1	1.35
Y	0.9
Y1	2.9

(2) Package Type: SOT25

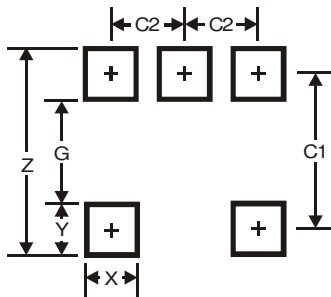

Dimensions	Value
Z	3.20
G	1.60
X	0.55
Y	0.80
C1	2.40
C2	0.95

(3) Package Type: SOT89

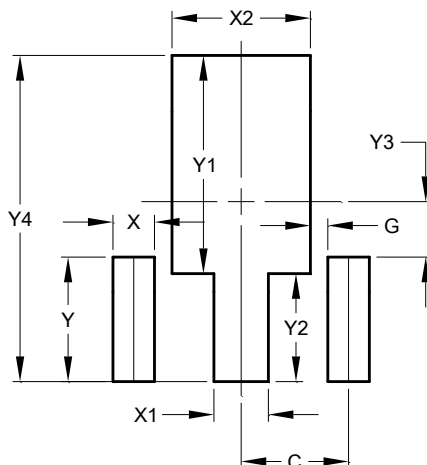

Dimensions	Value (in mm)
C	1.500
G	0.244
X	0.580
X1	0.760
X2	1.933
Y	1.730
Y1	3.030
Y2	1.500
Y3	0.770
Y4	4.530

Suggested Pad Layout (continued)

Please see <http://www.diodes.com/package-outlines.html> for the latest version.

(4) Package Type: U-DFN2020-6 (Type C)

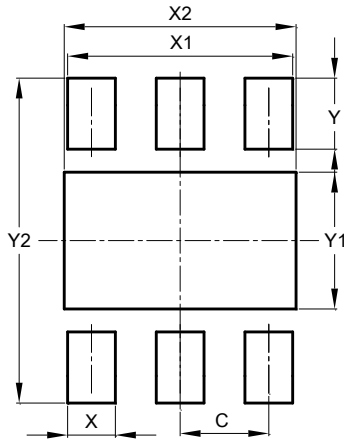

Dimensions	Value (in mm)
C	0.650
X	0.350
X1	1.650
X2	1.700
Y	0.525
Y1	1.010
Y2	2.400

IMPORTANT NOTICE

DIODES INCORPORATED MAKES NO WARRANTY OF ANY KIND, EXPRESS OR IMPLIED, WITH REGARDS TO THIS DOCUMENT, INCLUDING, BUT NOT LIMITED TO, THE IMPLIED WARRANTIES OF MERCHANTABILITY AND FITNESS FOR A PARTICULAR PURPOSE (AND THEIR EQUIVALENTS UNDER THE LAWS OF ANY JURISDICTION).

Diodes Incorporated and its subsidiaries reserve the right to make modifications, enhancements, improvements, corrections or other changes without further notice to this document and any product described herein. Diodes Incorporated does not assume any liability arising out of the application or use of this document or any product described herein; neither does Diodes Incorporated convey any license under its patent or trademark rights, nor the rights of others. Any Customer or user of this document or products described herein in such applications shall assume all risks of such use and will agree to hold Diodes Incorporated and all the companies whose products are represented on Diodes Incorporated website, harmless against all damages.

Diodes Incorporated does not warrant or accept any liability whatsoever in respect of any products purchased through unauthorized sales channel. Should Customers purchase or use Diodes Incorporated products for any unintended or unauthorized application, Customers shall indemnify and hold Diodes Incorporated and its representatives harmless against all claims, damages, expenses, and attorney fees arising out of, directly or indirectly, any claim of personal injury or death associated with such unintended or unauthorized application.

Products described herein may be covered by one or more United States, international or foreign patents pending. Product names and markings noted herein may also be covered by one or more United States, international or foreign trademarks.

This document is written in English but may be translated into multiple languages for reference. Only the English version of this document is the final and determinative format released by Diodes Incorporated.

LIFE SUPPORT

Diodes Incorporated products are specifically not authorized for use as critical components in life support devices or systems without the express written approval of the Chief Executive Officer of Diodes Incorporated. As used herein:

A. Life support devices or systems are devices or systems which:

1. are intended to implant into the body, or
2. support or sustain life and whose failure to perform when properly used in accordance with instructions for use provided in the labeling can be reasonably expected to result in significant injury to the user.

B. A critical component is any component in a life support device or system whose failure to perform can be reasonably expected to cause the failure of the life support device or to affect its safety or effectiveness.

Customers represent that they have all necessary expertise in the safety and regulatory ramifications of their life support devices or systems, and acknowledge and agree that they are solely responsible for all legal, regulatory and safety-related requirements concerning their products and any use of Diodes Incorporated products in such safety-critical, life support devices or systems, notwithstanding any devices- or systems-related information or support that may be provided by Diodes Incorporated. Further, Customers must fully indemnify Diodes Incorporated and its representatives against any damages arising out of the use of Diodes Incorporated products in such safety-critical, life support devices or systems.

Copyright © 2019, Diodes Incorporated

www.diodes.com