

© - TE Connectivity. All Rights Reserved.

REVISIONS				
P	LTR	DESCRIPTION	DATE	APVD
	N	REVISED PER ECR-22-152397	07OCT2022	BB DSC

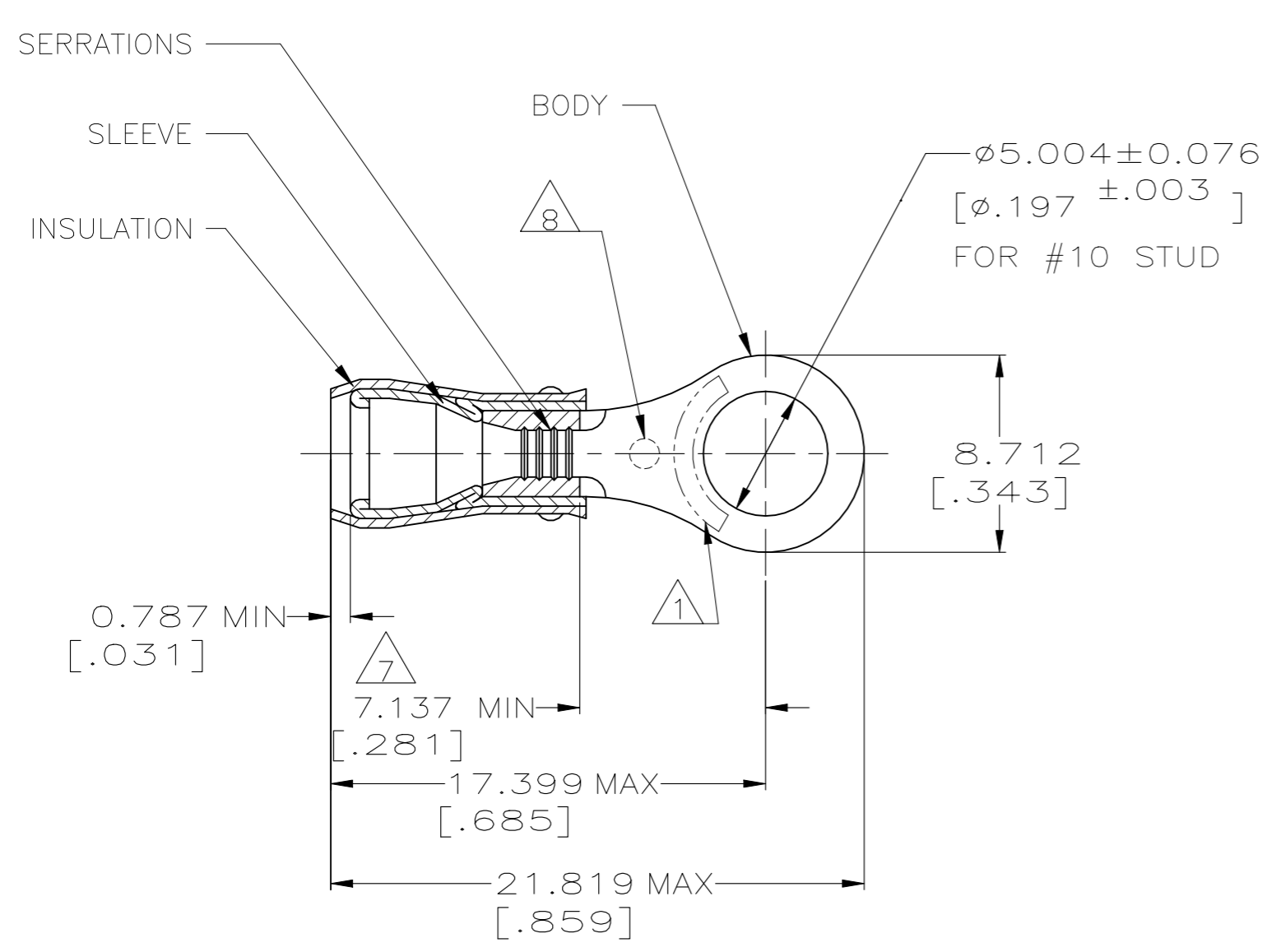

AMP WIRE RANGE	Listed FILE E13288	LR7189 Certified
16-14 AWG SOLID OR STRANDED	16-14 AWG SOLID OR STRANDED	16-14 AWG SOLID OR STRANDED

- 1 STAMP AMP 16-14* APPROX AS SHOWN
- 2 WIRE INSULATION DIAMETER:
 $\phi 2.921 [.115]$ TO $\phi 4.318 [.170]$
- 3 BODY MATERIAL THK:
 $0.787 \pm 0.051 [.031 \pm .002]$
- 4 NOTE DELETED
- 5 MATERIAL:
BODY & SLEEVE - COPPER PER ASTM B152
INSULATION - NYLON
- 6 FINISH:
BODY & SLEEVE - TIN PLATE $0.00254 [.000100]$
MIN EXT THK PER ASTM B545
INSULATION COLOR - BLUE
- 7 APPLIES FROM EGDE OF METAL WIRE BARREL TO
CENTER OF STUD HOLE
- 8 "O" STAMP MARK OPTIONAL

100	LOOSE PIECE, BOX	8-36160-1
5000	ON TAPE, REEL	2-36160-1
1000	LOOSE PIECE	36160
QUANTITY	PACKAGE TYPE	PART NO

AMP INCORPORATED CUSTOMER SERVICE SYSTEMS		MAX RECOMMENDED OPERATING TEMPERATURE: 105° C [221° F]	THIS DRAWING IS A CONTROLLED DOCUMENT.		DWN JR RUTH 17DEC99	TE Connectivity			
FOR ADDITIONAL PRODUCT INFORMATION OR COPIES OF DRAWINGS AND TECHNICAL DOCUMENTS	PRODUCT INFORMATION CENTER 1-800-522-6752	VOLTAGE RATING: 300 V MAX	DIMENSIONS: mm [INCHES]	TOLERANCES UNLESS OTHERWISE SPECIFIED:	CHK RE HERSEY 17DEC99				NAME
FOR APPLICATION TOOLING INFORMATION	TOOLING ASSISTANCE CENTER 1-800-722-1111	WIRE CROSS SECTIONAL AREA RANGE: 1.04-2.62mm ² [2050-5180] CIR MILS SOLID OR STRANDED		0 PLC ± - 1 PLC ± - 2 PLC ± - 3 PLC ± 0.127[.005] 4 PLC ± - ANGLES ± -	APVD T MICHELUTTI 17DEC99	TERMINAL, RING TONGUE, PIDG™, WIRE SIZE: 16-14 AWG			
FOR ORDER ENTRY	1-800-526-5142	THIS DRAWING IS A CONTROLLED DOCUMENT FOR AMP INCORPORATED. IT IS SUBJECT TO CHANGE AND THE CONTROLLING ENGINEERING ORGANIZATION SHOULD BE CONTACTED FOR THE LATEST REVISION.	MATERIAL	FINISH	PRODUCT SPEC UL 486A-B	SIZE	CAGE CODE	DRAWING NO	RESTRICTED TO
			5	6	APPLICATION SPEC 114-2157	A3	00779	C-36160	-
					WEIGHT	CUSTOMER DRAWING		SCALE	SHEET
					-	4:1		1 OF 1	REV N