

**ARM[®] Cortex[®]-M
32-bit Microcontroller**

**NuMaker-ETM-M487
User Manual
NuMicro[®] M480 Series**

The information described in this document is the exclusive intellectual property of Nuvoton Technology Corporation and shall not be reproduced without permission from Nuvoton.

Nuvoton is providing this document only for reference purposes of NuMicro microcontroller based system design. Nuvoton assumes no responsibility for errors or omissions.

All data and specifications are subject to change without notice.

For additional information or questions, please contact: Nuvoton Technology Corporation.

www.nuvoton.com

Table of Contents

1 Overview 5

 1.1 Introduction to NuMaker-ETM-M487 Board 5

 1.2 M487 Series MCU Features 6

 1.3 NuMaker-ETM-M487 Board Features 7

2 NuMaker-ETM-M487 Board Overview 8

 2.1 View 8

 2.2 Arduino UNO Compatible Interface 9

 2.3 Pin Assignment for Extended Connectors 11

 2.4 System Configuration 16

 2.4.1 5V Power Source 16

 2.4.2 3.3V Power Source 16

 2.4.3 USB Connectors 17

 2.4.4 Arduino UNO Compatible Interface Connectors 17

 2.4.5 Extended Connectors 17

 2.4.6 Push-Buttons 17

 2.4.7 LEDs 17

 2.4.8 Power Connectors 17

 2.4.9 ETM Connectors 17

 2.5 Nu-Link-Me 18

 2.6 ETM Interface 18

 2.7 PCB Placement 19

3 NuMaker-ETM-M487 Schematics 20

 3.1 Nu-Link-Me 20

 3.2 M487JIDAE 21

 3.3 Power Supply 22

 3.4 Arduino UNO Compatible Interface 23

 3.5 Extended Interface Connectors 24

 3.6 USB 2.0 HS OTG and USB 1.1 FS OTG 25

4 REVISION HISTORY 26

List of Figures

Figure 1-1 NuMaker-ETM-M487 Board 5

Figure 2-1 Front View of NuMaker-ETM-M487 Board 8

Figure 2-2 Arduino UNO Compatible Interface 9

Figure 2-3 M487JIDAE Extended Connectors 11

Figure 2-4 Front Placement 19

Figure 2-5 Rear Placement 19

Figure 3-1 Nu-Link-Me Circuit 20

Figure 3-2 M487JI8AE Pin Assignment 21

Figure 3-3 Power Circuit and Configurations 22

Figure 3-4 Arduino UNO Compatible Interface 23

Figure 3-5 Extended Interface Connectors 24

Figure 3-6 USB HS OTG and FS OTG Circuits 25

List of Tables

Table 2-1 Arduino UNO Interface Mapping with M487JIDAE GPIO 10

Table 2-2 Extended Connector JP1 Interface with M487JIDAE GPIO 12

Table 2-3 Extended Connector JP2 Interface with M487JIDAE GPIO 13

Table 2-4 Extended Connector JP3 Interface with M487JIDAE GPIO 14

Table 2-5 Extended Connector JP4 Interface with M487JIDAE GPIO 15

Table 2-6 Optional Function of Nu-Link-Me 18

Table 2-7 Pin mapping of ETM Connector 18

1 OVERVIEW

This user manual is aimed to give users a fast introduction to the use NuMaker-ETM-M487 board to develop their own application and show how to use the ETM interface to trace their code.

1.1 Introduction to NuMaker-ETM-M487 Board

The NuMaker-ETM-M487 is a development board based on an ARM[®] Cortex[®]-M4 microcontroller (MCU) – M480 series which has very rich peripherals.

The NuMaker-ETM-M487 also provides user many useful and powerful learning materials for how to develop and verify the application programs through the peripherals and interfaces on MCU and this board.

Furthermore, this board also provides an Arduino UNO compatible interface for user to develop the specific function with any of Arduino modules or kits. Regarding to the Arduino, user can link directly to the Wikipedia website: en.wikipedia.org/wiki/Arduino to get more detailed introductions.

The NuMaker-ETM-M487 board consists of M487 Platform and Nu-Link-Me ICE Bridge. Figure 1-1 shows the NuMaker-ETM-M487 board.

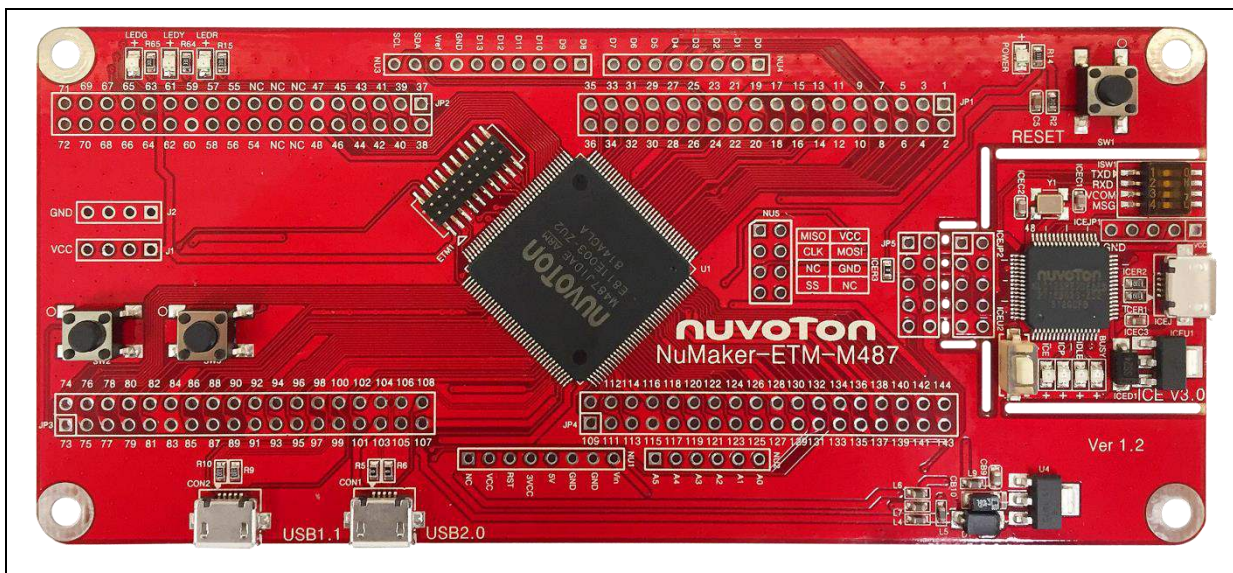

Figure 1-1 NuMaker-ETM-M487 Board

The left portion of this board is the M487 Platform that includes the target chip M487 MCU which embedded ARM[®] Cortex[®]-M4 core with DSP extensions and a Floating Point Unit (FPU) and the other related on-board application parts and connectors.

The right portion of this board is a Nu-Link-Me ICE Bridge based on the SWD (Serial Wire Debug) interface connected with the target chip, allowing user to program the application code to the flash of target chip through the USB port from PC Host. NuMaker-ETM-M487 also provides standard 20-pin ARM Cortex-Debug+ETM connector, let user to use ETM interface to trace and debug.

1.2 M487 Series MCU Features

- M487JIDAE in LQFP144 package
- ARM® Cortex®-M4 core running up to 192 MHz with DSP extensions and FPU (Floating Point Unit)
- Built-in LDO for wide operating voltage ranged from 1.8 V to 3.6 V
- 512 Kbytes Flash
- 160 Kbytes SRAM
- External Bus Interface (EBI)
- GPIO
- Peripheral DMA (PDMA)
- Timer
- PWM and BPWM
- Quadrature Encoder Interface (QEI)
- WDT and WWDT
- RTC
- UART
- Smart Card (ISO-7816-3) Host Interface
- I²C
- SPI
- SPIM
- I²S
- Universal Serial Control Interface (USCI)
- USB 2.0 High-Speed OTG / Host / Device
- USB 1.1 Full-Speed OTG / Host / Device
- CAN 2.0
- Ethernet MAC
- SD Host
- Cryptographic Accelerator
- CRC
- ADC
- DAC
- Comparator

1.3 NuMaker-ETM-M487 Board Features

- On board Nu-Link-Me ICE Bridge (Mass storage as USB Disk drive) for drag and drop programming
- Arduino UNO compatible interface
- M487 extended interface connectors
- USB 2.0 High-Speed OTG / Host / Device
- USB 1.1 Full-Speed OTG / Host / Device
- Three push-buttons: one is for reset and the other two are for user-defined
- Four LEDs: one is for power indication and the other three are for user-defined
- ARM Cortex-Debug+ETM connector

2 NUMAKER-ETM-M487 BOARD OVERVIEW

2.1 View

Figure 2-1 shows the main components and connectors from the front side of NuMaker-ETM-M487 board.

The following lists components and connectors from the front view:

- Target Chip: M487JIDAE (U1)
- Nu-Link-Me ICE Bridge: ICE Controller NUC12SRE3DE (ICEU2), USB connector (ICEJ) to PC Host
- Arduino UNO compatible interface connectors (NU1, NU2, NU3, NU4 and NU5)
- M487 extended interface connectors (JP1, JP2, JP3 and JP4)
- USB: USB 2.0 High-Speed OTG connector (CON1) and USB 1.1 OTG connector (CON2)
- Push-buttons (SW2, SW3)
- LEDs (LEDR, LEDY and LEDG)
- 3VCC connector (J1) and GND connector (J2)

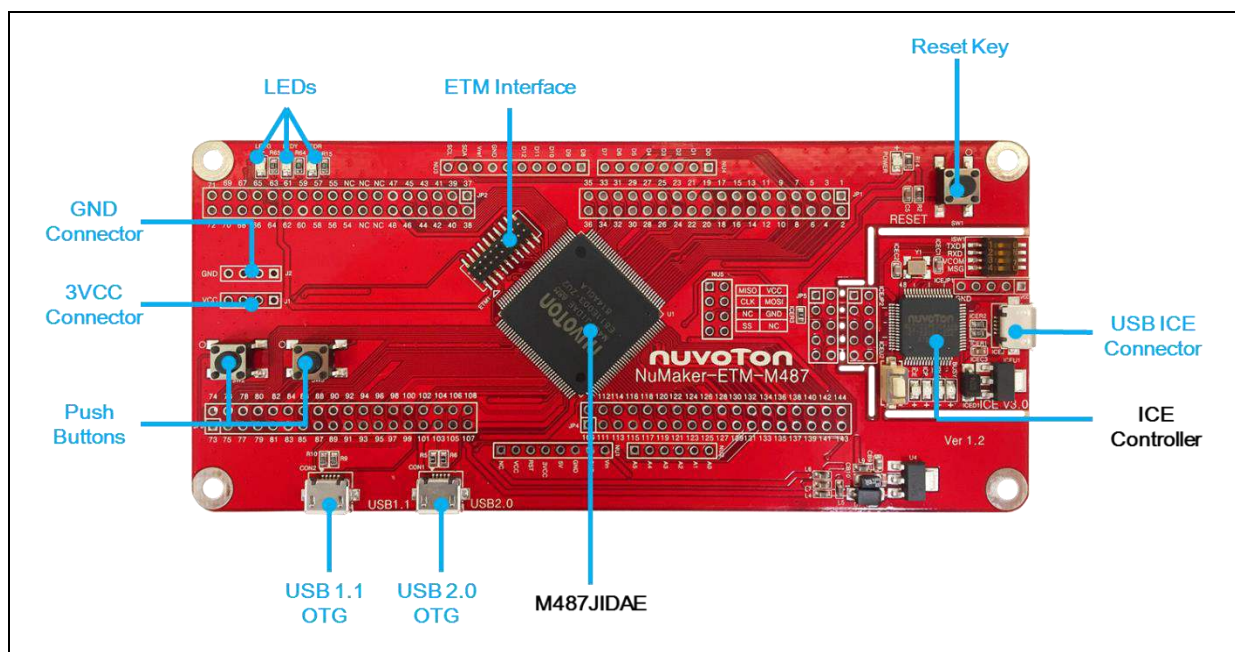

Figure 2-1 Front View of NuMaker-ETM-M487 Board

2.2 Arduino UNO Compatible Interface

Figure 2-2 shows the Arduino UNO compatible interface.

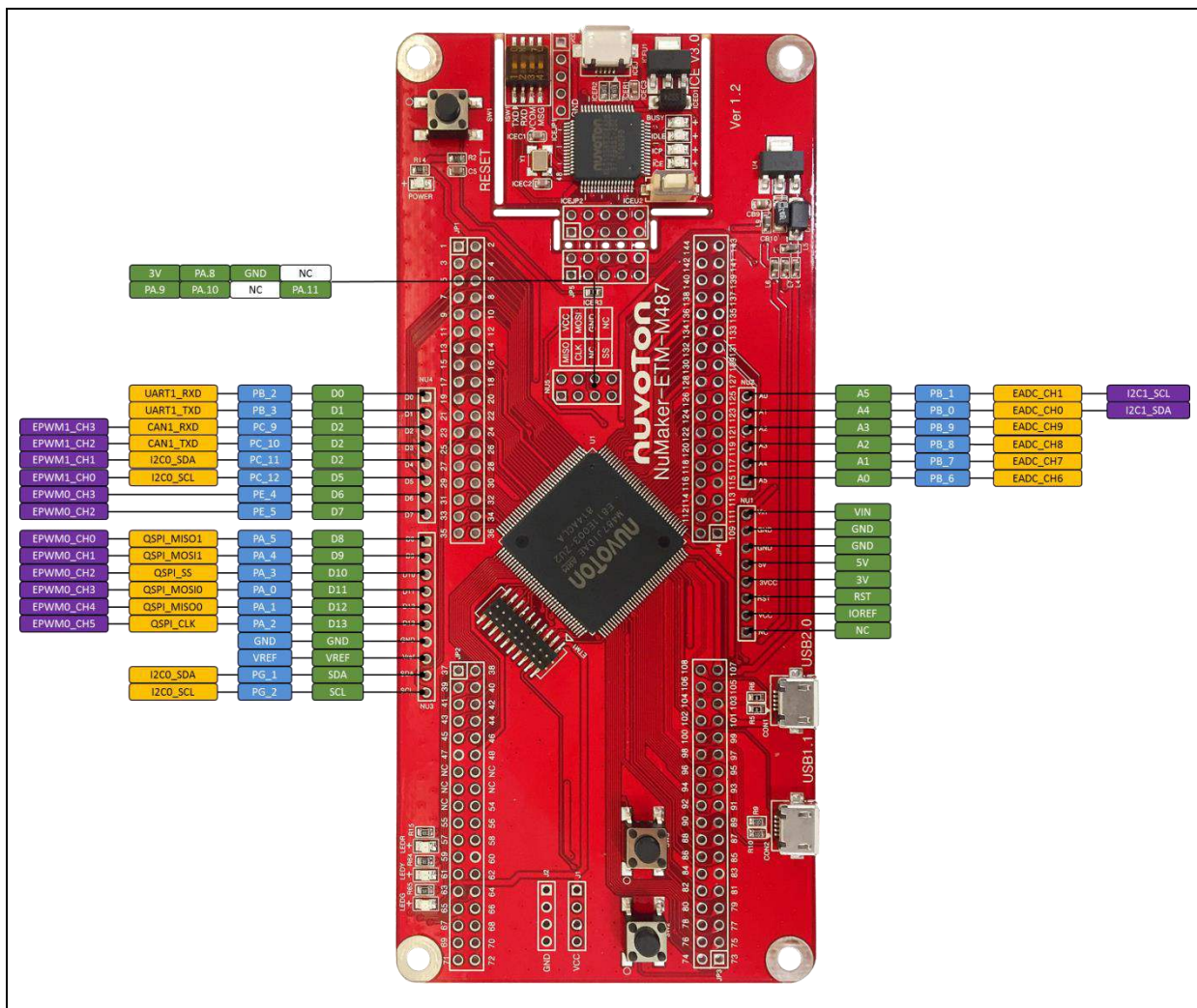

Figure 2-2 Arduino UNO Compatible Interface

Table 2-1 Arduino UNO Interface Mapping with M487JIDAE GPIO

Header		NuMaker-ETM-M487		Header		NuMaker-ETM-M487	
		Compatible to Arduino UNO	GPIO Pin of M487			Compatible to Arduino UNO	GPIO Pin of M487
NU1	NU1.1	NC	-	NU6.10	SCL	PG.0	
	NU1.2	IOREF		NU6.9	SDA	PG.1	
	NU1.3	RESET	RESET	NU6.8	VREF	-	
	NU1.4	3VCC	-	NU6.7	GND		
	NU1.5	5VCC		NU6.6	D13	PA.2	
	NU1.6	GND		NU6.5	D12	PA.1	
	NU1.7	GND		NU6.4	D11	PA.0	
	NU1.8	VIN		NU6.3	D10	PA.3	
NU2	NU2.1	A0		PB.6	NU6.2	D9	PA.4
	NU2.2	A1	PB.7	NU6.1	D8	PA.5	
	NU2.3	A2	PB.8	NU5.8	D7	PE.5	
	NU2.4	A3	PB.9	NU5.7	D6	PE.4	
	NU2.5	A4	PB.0	NU5.6	D5	PC.12	
	NU2.6	A5	PB.1	NU5.5	D4	PC.11	
NU3	NU6.10	SCL	PG.0	NU5.4	D3	PC.10	
	NU6.9	SDA	PG.1	NU5.3	D2	PC.9	
	NU6.8	VREF	-	NU5.2	D1	PB.3	
	NU6.7	GND	-	NU5.1	D0	PB.2	
	NU6.6	D13	PA.2				
NU4	NU6.5	D12	PA.1				
	NU6.4	D11	PA.0				
	NU6.3	D10	PA.3				
	NU6.2	D9	PA.4				

Header		NuMaker-ETM-M487		Header		NuMaker-ETM-M487	
		Compatible to Arduino UNO	GPIO Pin of M487			Compatible to Arduino UNO	GPIO Pin of M487
NU5	NU7.1	VCC	-	NU7.2	MISO	PA.9	
	NU7.3	CLK	PA.10	NU7.4	MOSI	PA.8	
	NU7.5	NC	-	NU7.6	GND	-	
	NU7.7	SS	PA.11	NU7.8	NC	-	

2.3 Pin Assignment for Extended Connectors

The NuMaker-ETM-M487 provides the M487JIDAE target chip onboard and extended connectors (JP1, JP2, JP3 and JP4) for LQFP144-pin. The Figure 2-3 shows the M487JIDAE extended connectors.

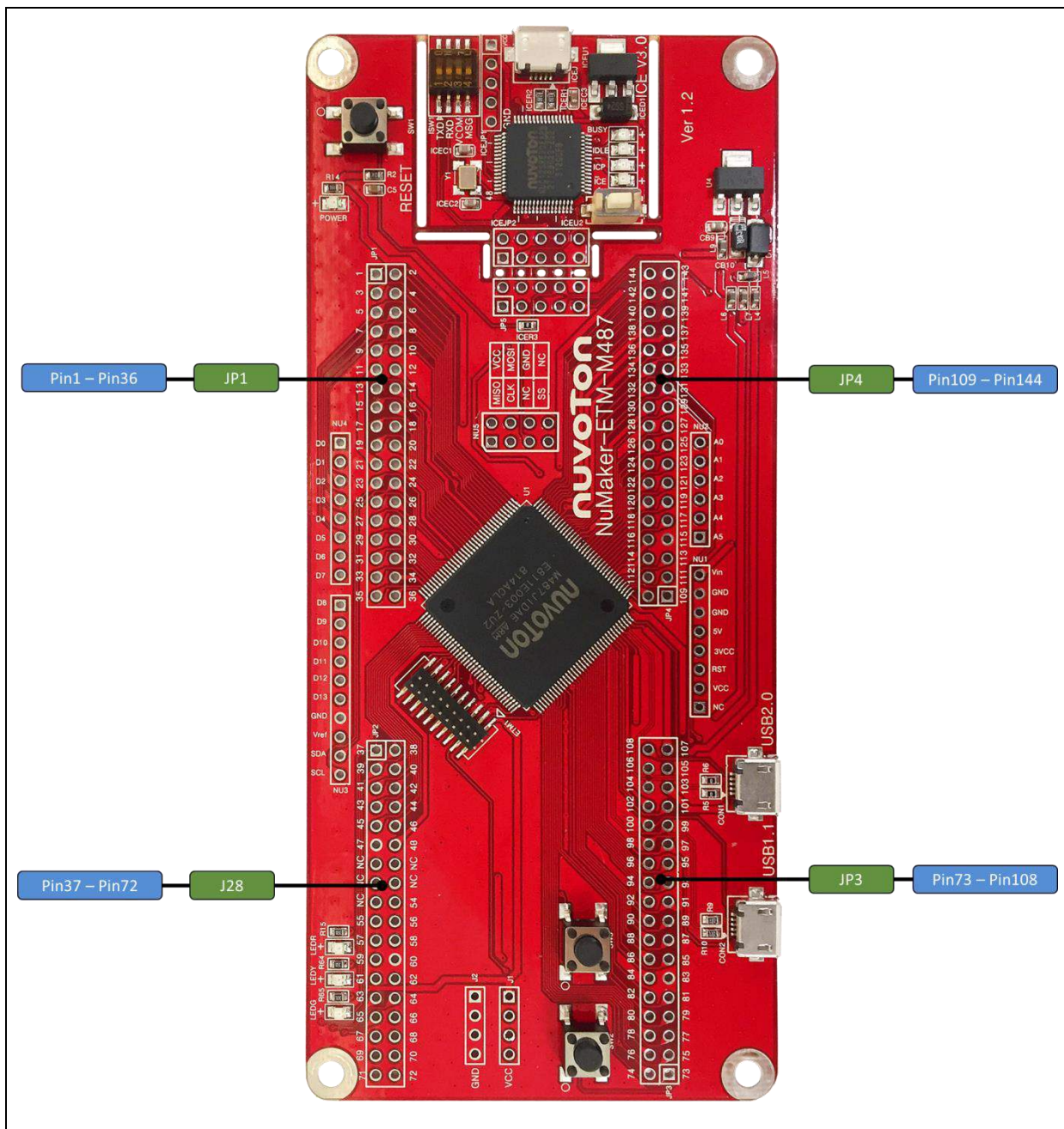

Figure 2-3 M487JIDAE Extended Connectors

Table 2-2 Extended Connector JP1 Interface with M487JIDAE GPIO

Header		M487JIDAE		Header		M487JIDAE	
		Pin No.	Function			Pin No	Function
JP1	JP1.1	1	PB.5	JP1	JP1.2	2	PB.4
	JP1.3	3	PB.3		JP1.4	4	PB.2
	JP1.5	5	PC.12		JP1.6	6	PC.11
	JP1.7	7	PC.10		JP1.8	8	PC.9
	JP1.9	9	PB.1		JP1.10	10	PB.0
	JP1.11	11	VSS		JP1.12	12	VDD
	JP1.13	13	PA.11		JP1.14	14	PA.10
	JP1.15	15	PA.9		JP1.16	16	PA.8
	JP1.17	17	PC.13		JP1.18	18	PD.12
	JP1.19	19	PD.11		JP1.20	20	PD.10
	JP1.21	21	VSS		JP1.22	22	VDD
	JP1.23	23	PG.0		JP1.24	24	PG.1
	JP1.25	25	PG.2		JP1.26	26	PG.3
	JP1.27	27	PG.4		JP1.28	28	PF.11
	JP1.29	29	PF.10		JP1.30	30	PF.9
	JP1.31	31	PF.8		JP1.32	32	PF.7
	JP1.33	33	PF.6		JP1.34	34	VDD
JP1.35	35	PF.5	JP1.36	36	PF.4		

Table 2-3 Extended Connector JP2 Interface with M487JIDAE GPIO

Header		M487JIDAE		Header		M487JIDAE	
		Pin No.	Function			Pin No	Function
JP2	JP2.1	37	LED_R	JP2	JP2.2	38	LED_Y
	JP2.3	39	LED_G		JP2.4	40	PH.3
	JP2.5	41	PH.4		JP2.6	42	PH.5
	JP2.7	43	PH.6		JP2.8	44	PH.7
	JP2.9	45	PF.3		JP2.10	46	PF.2
	JP2.11	47	VSS		JP2.12	48	VDD
	JP2.13	49	PE.8		JP2.14	50	PE.9
	JP2.15	51	PE.10		JP2.16	52	PE.11
	JP2.17	53	PE.12		JP2.18	54	PE.13
	JP2.19	55	PC.8		JP2.20	56	PC.7
	JP2.21	57	PC.6		JP2.22	58	PA.7
	JP2.23	59	PA.6		JP2.24	60	VSS
	JP2.25	61	VDD		JP2.26	62	LDO_CAP
	JP2.27	63	PA.5		JP2.28	64	PA.4
	JP2.29	65	PA.3		JP2.30	66	PA.2
	JP2.31	67	PA.1		JP2.32	68	PA.0
JP2.33	69	VDDIO	JP2.34	70	PE.14		
JP2.35	71	PE.15	JP2.36	72	nRESET		

Table 2-4 Extended Connector JP3 Interface with M487JIDAE GPIO

Header		M487JIDAE		Header		M487JIDAE	
		Pin No.	Function			Pin No	Function
JP3	JP3.1	73	PF.0	JP3	JP3.2	74	PF.1
	JP3.3	75	PD.9		JP3.4	76	PD.8
	JP3.5	77	PC.5		JP3.6	78	PC.4
	JP3.7	79	PC.3		JP3.8	80	PC.2
	JP3.9	81	PC.1		JP3.10	82	PC.0
	JP3.11	83	VSS		JP3.12	84	VDD
	JP3.13	85	PG.9		JP3.14	86	PG.10
	JP3.15	87	PG.11		JP3.16	88	PG.12
	JP3.17	89	PG.13		JP3.18	90	PG.14
	JP3.19	91	PG.15		JP3.20	92	PD.3
	JP3.21	93	PD.2		JP3.22	94	PD.1
	JP3.23	95	PD.0		JP3.24	96	PD.13
	JP3.25	97	PA.12		JP3.26	98	PA.13
	JP3.27	99	PA.14		JP3.28	100	PA.15
	JP3.29	101	HSUSB_VRES		JP3.30	102	HSUSB_VDD33
	JP3.31	103	HSUSB_VBUS		JP3.32	104	HSUSB_D-
	JP3.33	105	HSUSB_VSS		JP3.34	106	HSUSB_D+
JP3.35	107	HSUSB_VDD12 _CAP	JP3.36	108	HSUSB_ID		

Table 2-5 Extended Connector JP4 Interface with M487JIDAE GPIO

Header		M487JIDAE		Header		M487JIDAE	
		Pin No.	Pin Name			Pin No	Pin Name
JP4	JP4.1	109	PE.7	JP4	JP4.2	110	PE.6
	JP4.3	111	PE.5		JP4.4	112	PE.4
	JP4.5	113	PE.3		JP4.6	114	PE.2
	JP4.7	115	VSS		JP4.8	116	VDD
	JP4.9	117	PE.1		JP4.10	118	PE.0
	JP4.11	119	PH.8		JP4.12	120	PH.9
	JP4.13	121	PH.10		JP4.14	122	PH.11
	JP4.15	123	PD.14		JP4.16	124	PG.5
	JP4.17	125	PG.6		JP4.18	126	PG.7
	JP4.19	127	PG.8		JP4.20	128	VSS
	JP4.21	129	LDO_CAP		JP4.22	130	VDD
	JP4.23	131	USB_VBUS_ST		JP4.24	132	USB_VBUS_EN
	JP4.25	133	PB.14		JP4.26	134	PB.13
	JP4.27	135	PB.12		JP4.28	136	AVDD
	JP4.29	137	VREF		JP4.30	138	AVSS
	JP4.31	139	HSUSB_VBUS_ST		JP4.32	140	HSUSB_VBUS_EN
	JP4.33	141	PB.9		JP4.34	142	PB.8
JP4.35	143	PB.7	JP4.36	144	PB.6		

2.4 System Configuration

2.4.1 5V Power Source

- **ICEJ:** USB connector in Nu-Link-Me to program code and supplies 5V power from PC Host.
- **CON1:** USB 2.0 High-Speed OTG connector on NuMaker-ETM-M487 board to supply 5V power from PC Host.
- **CON2:** USB 1.1 OTG connector on NuMaker-ETM-M487 board to supply 5V power from PC Host .
- **NU1.8:** VDD5V pin on NuMaker-ETM-M487 board to supply 5V power from external power source.

Power Source	Connector	Comment
ICE_USB_VBUS	ICEJ	ICEJ supplies the 5V power from PC Host. Note: L6 should be shorted 0ohm
HSUSB_VBUS	CON1	CON1 supplies the 5V power from PC Host. Note: L4 and L7 should be shorted 0ohm.
USB_VBUS	CON2	CON2 supplies the 5V power from PC Host. Note: L5 and L7 should be shorted 0ohm.
External 5V Source	NU1.8	NU1 pin8 supplies the 5V power from external power source.

2.4.2 3.3V Power Source

- **ICEU1:** The voltage regular converts the 5V source to 3.3V and supplies it to NuMaker-ETM-M487 board.
- **U4:** The voltage regular converts the 5V source to 3.3V and supplies it to NuMaker-ETM-M487 board.

Voltage Regular	5V Source	Comment
ICEU1	ICE_USB_VBUS	ICEU1 convert ICE_USB_VBUS to 3.3V and supplies it to M487 platform board. Note: L8 should be shorted 0ohm
U4	HSUSB_VBUS	U4 convert HSUSB_VBUS to 3.3V and supplies it to M487 platform board. Note: L9 should be shorted 0ohm.
U4	USB_VBUS	U4 convert USB_VBUS to 3.3V and supplies it to M487 platform board. Note: L9 should be shorted 0ohm.

2.4.3 USB Connectors

- **ICEJ:** USB connector (ICE) in Nu-Link-Me that connects to a PC's USB Host port to program code and supply power.
- **CON1:** USB 2.0 High-Speed connector (OTG) on NuMaker-ETM-M487 board for USB OTG application use.
- **CON2:** USB 1.1 connector (OTG) on NuMaker-ETM-M487 board for USB OTG application use.

2.4.4 Arduino UNO Compatible Interface Connectors

- **NU1, NU2, NU3, NU4 and NU5:** Arduino UNO compatible pins on the NuMaker-ETM-M487 board.

2.4.5 Extended Connectors

- **JP1, JP2, JP3 and JP4:** Extended connectors interface pins on the NuMaker-ETM-M487 board.

2.4.6 Push-Buttons

- **SW1:** Reset button to reset the target chip on NuMaker-ETM-M487 board.
- **SW2, SW3:** Only for application use.

2.4.7 LEDs

- **POWER:** The power LED indicates that the NuMaker-ETM-M487 board is powered.
- **LEDR, LEDY and LEDG:** Only for application use.

2.4.8 Power Connectors

- **J1:** 3VCC connectors on the NuMaker-ETM-M487 board.
- **J2:** GND connectors on the NuMaker-ETM-M487 board.

2.4.9 ETM Connectors

- **ETM1:** Standard 20-pin ARM Cortex-Debug+ETM connector to trace and debug.

2.5 Nu-Link-Me

NuMaker-ETM-M487 features a Nu-Link-Me ICE debugger and programmer, it provide user to program M487J18AE and debug their application via SWD interface, or it can emulate a USB pen driver when connect to the PC, user can update their firmware by pulling bin file to the pen driver. Nu-link-Me can also emulate a virtual COM port, user can log or print debug message via it. Refer Table 2-6 to enable or disable optional function of Nu-Link-Me.

Table 2-6 Optional Function of Nu-Link-Me

ISW1		
Pin	Nu-Link-Me	Comment
1	TXD	On: Connect PB.13 (UART0_TXD) of M487J18AE to Nu-Link-Me. Off: Disconnect PB.13 (UART0_TXD) of M487J18AE to Nu-Link-Me.
2	RXD	On: Connect PB.12 (UART0_RXD) of M487J18AE to Nu-Link-Me. Off: Disconnect PB.12 (UART0_RXD) of M487J18AE to Nu-Link-Me.
3	VCOM	On: Enable Nu-Link-Me virtual COM port function. Off: Disable Nu-Link-Me virtual COM port function.
4	MSG	On: Mass storage mode, user can update firmware by pulling bin file to pen driver. Off: Normal ICE mode, user can debugger and program via SWD interface.

2.6 ETM Interface

NuMaker-ETM-M487 features a standard 20-pin ARM Cortex-Debug+ETM connector and provides access to SWD and ETM (Embedded Trace Macrocell) signals. The Table 2-7 shows the pin mapping of ETM connector.

Table 2-7 Pin mapping of ETM Connector

ETM1			
Pin	Name	Pin	Name
1	VDD	2	SWDIO
3	GND	4	SWDCLK
5	GND	6	NC
7	NC	8	NC
9	NC	10	nRESET
11	NC	12	TRACECLK
13	NC	14	TRACEDAT0
15	GND	16	TRACEDAT1
17	GND	18	TRACEDAT2
19	GND	20	TRACEDAT3

2.7 PCB Placement

Figure 2-4 and Figure 2-5 show the front and rear placement of NuMaker-ETM-M487 board.

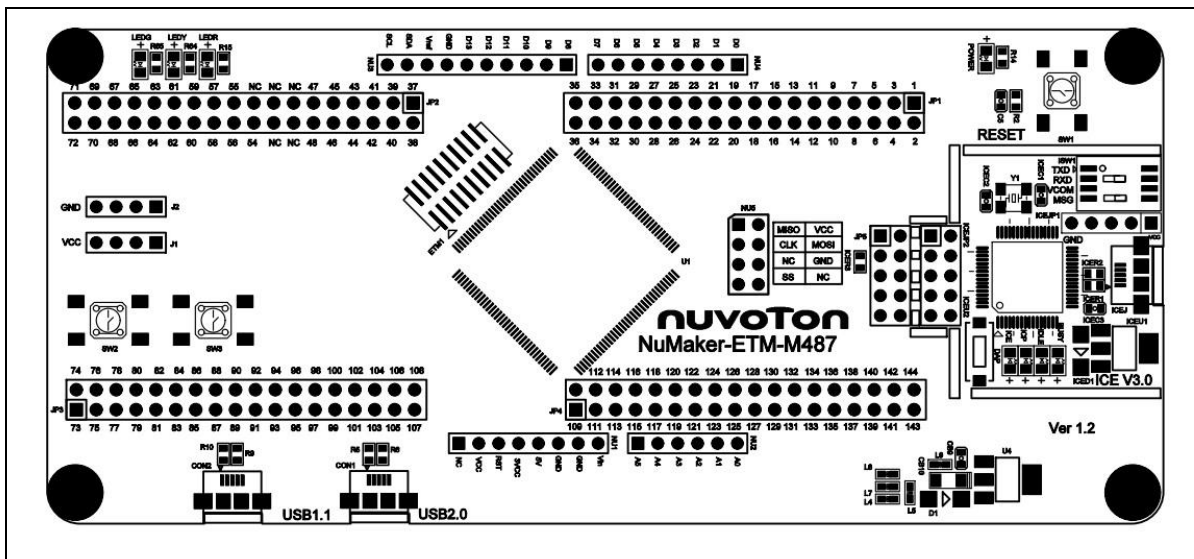

Figure 2-4 Front Placement

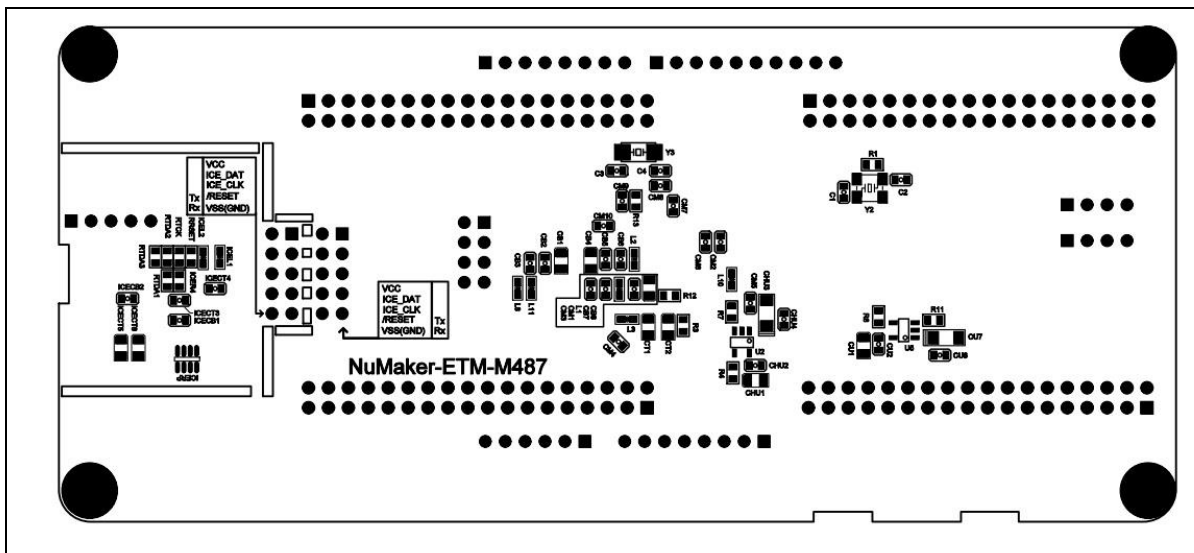

Figure 2-5 Rear Placement

3 NUMAKER-ETM-M487 SCHEMATICS

3.1 Nu-Link-Me

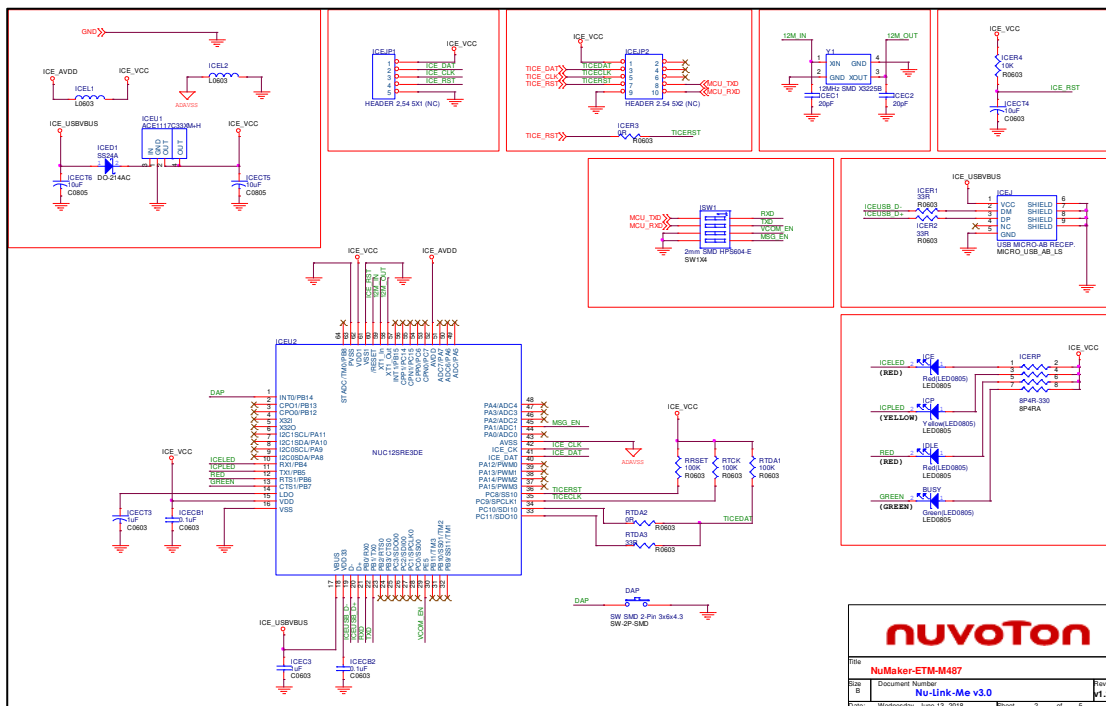

Figure 3-1 Nu-Link-Me Circuit

3.2 M487JIDAE

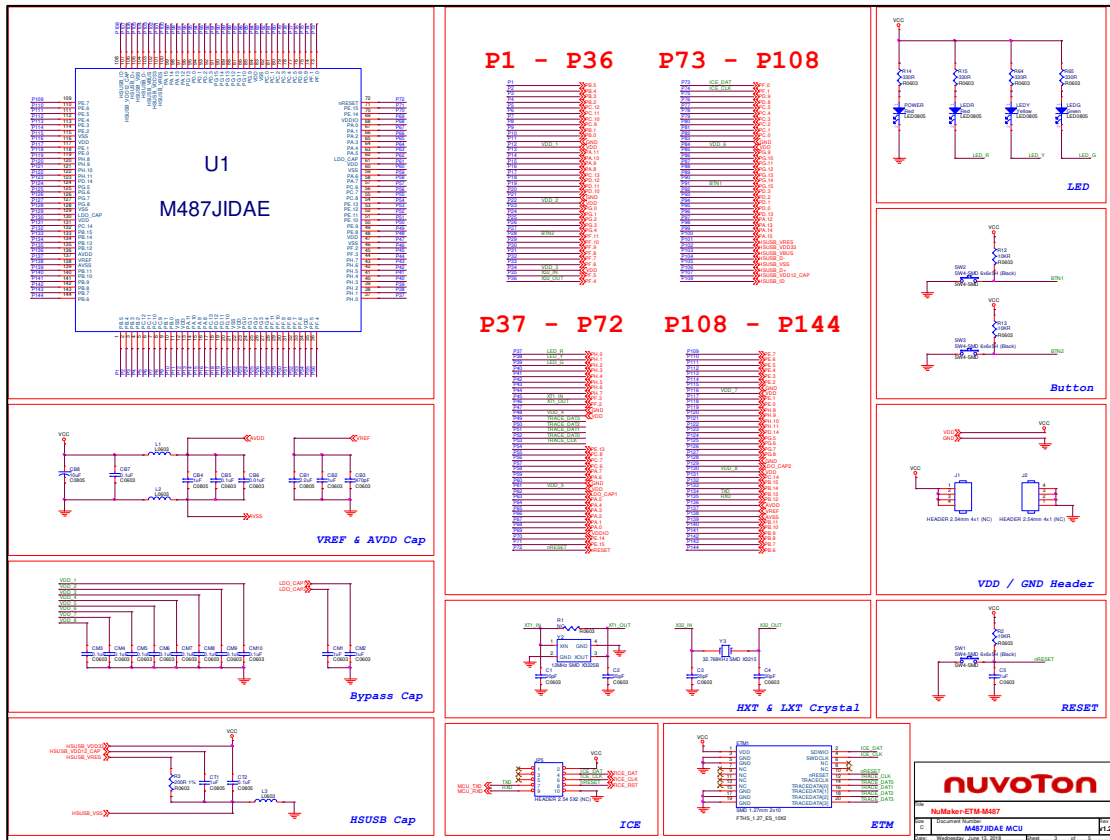

Figure 3-2 M487JIDAE Pin Assignment

3.3 Power Supply

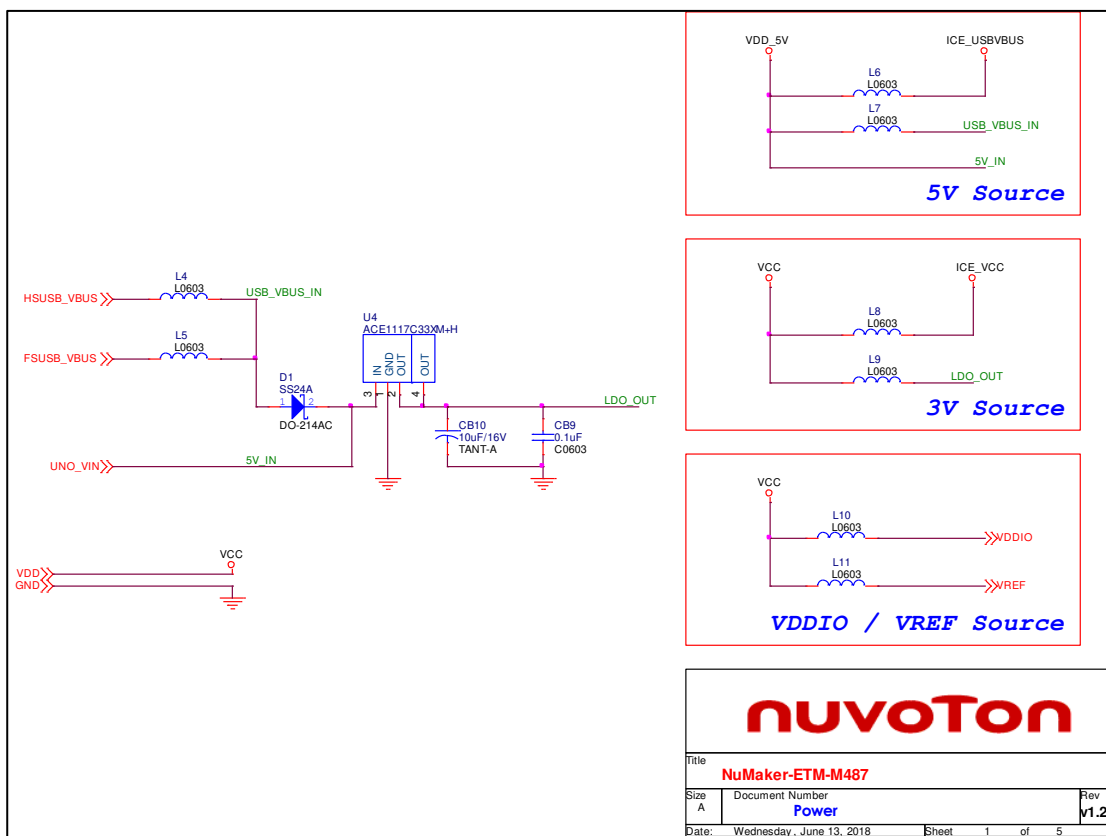

Figure 3-3 Power Circuit and Configurations

3.4 Arduino UNO Compatible Interface

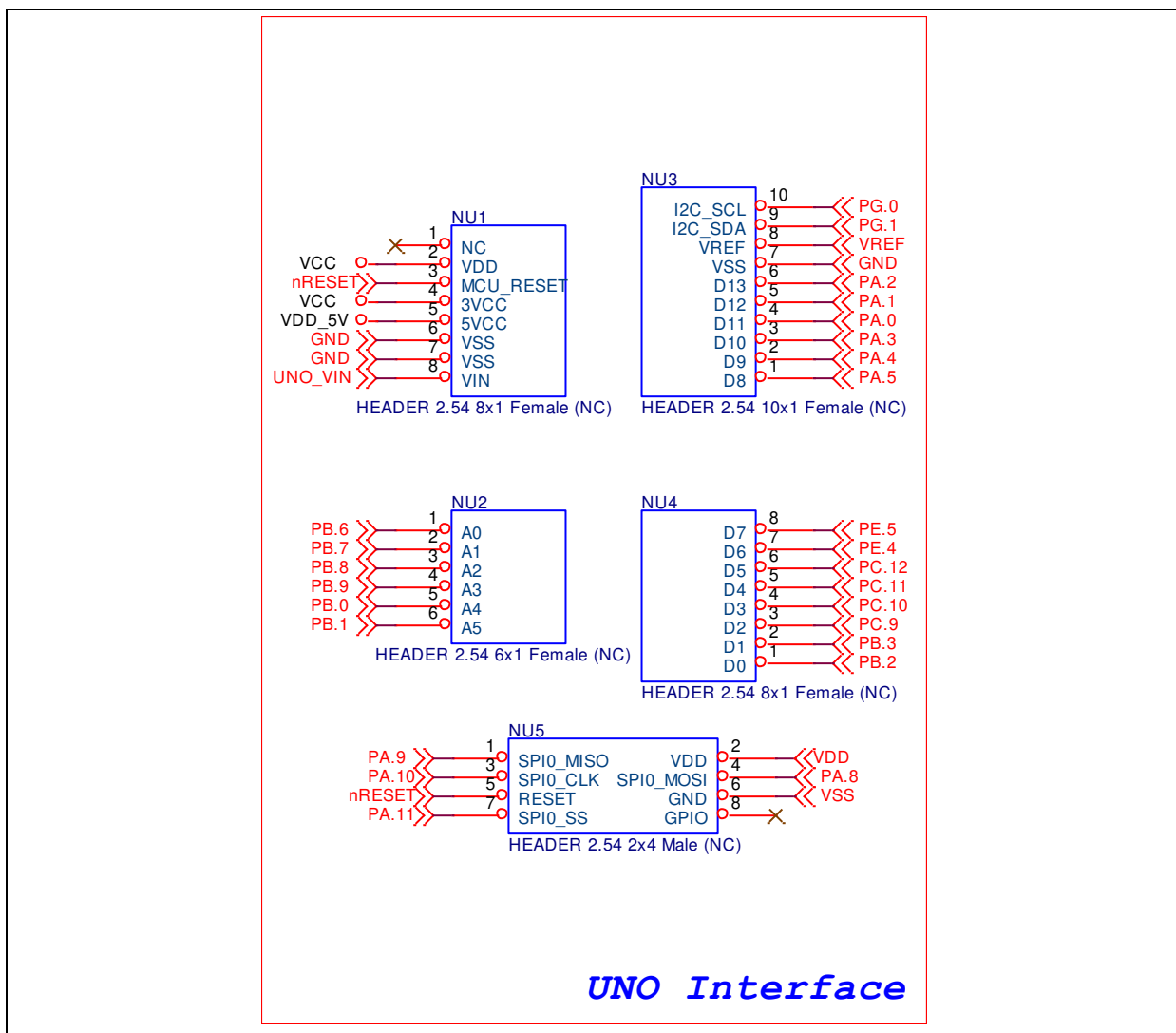

Figure 3-4 Arduino UNO Compatible Interface

3.5 Extended Interface Connectors

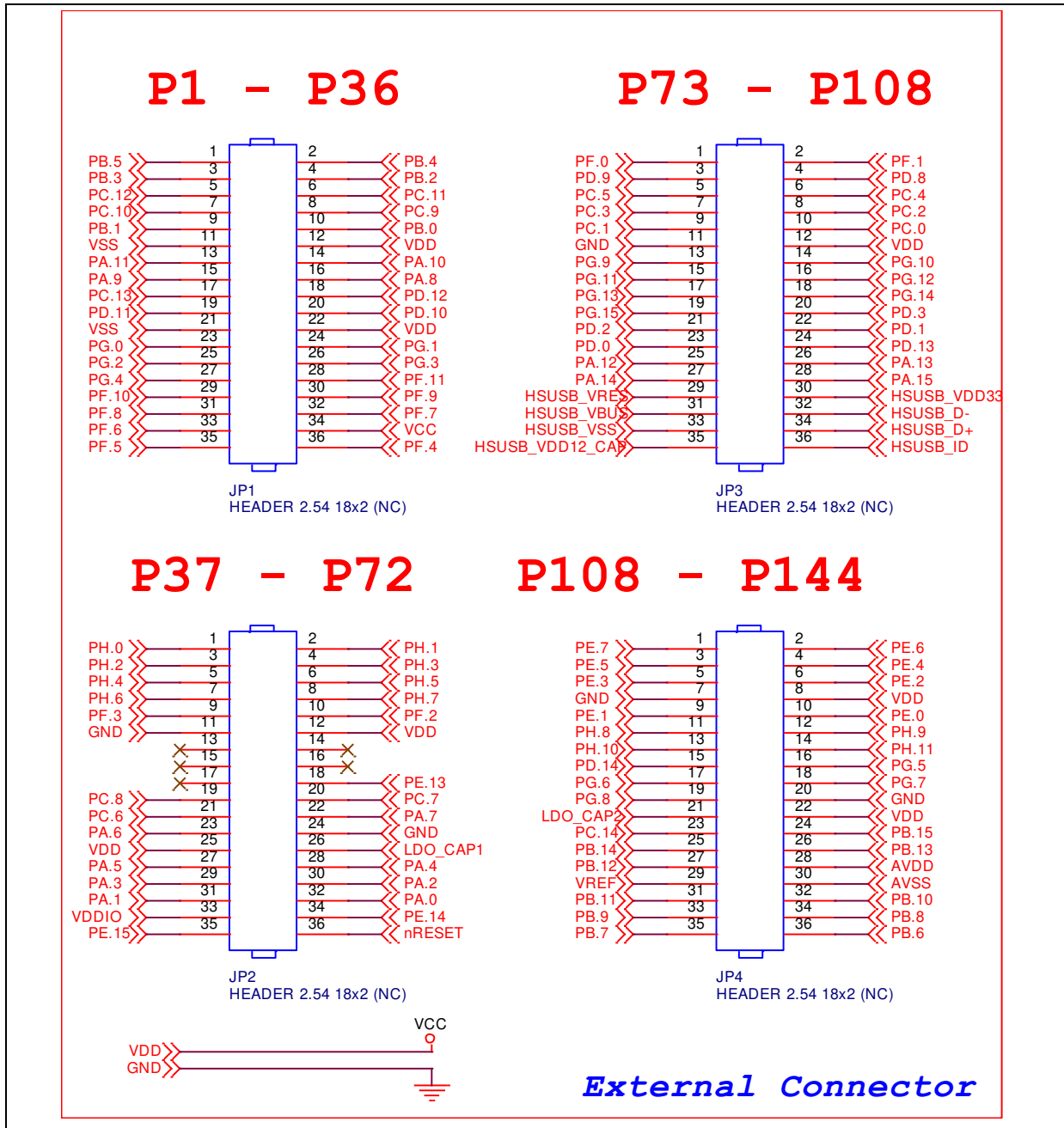

Figure 3-5 Extended Interface Connectors

3.6 USB 2.0 HS OTG and USB 1.1 FS OTG

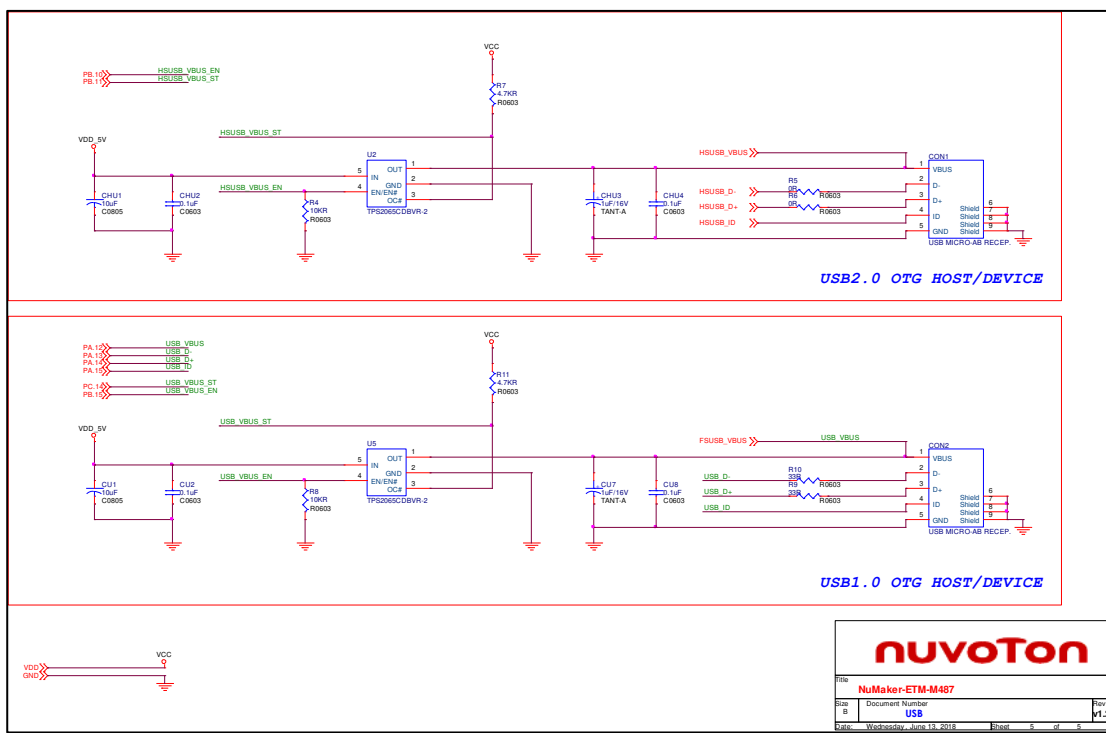

Figure 3-6 USB HS OTG and FS OTG Circuits

4 REVISION HISTORY

Date	Revision	Description
2018.07.04	1.00	1. Initially issued.
2019.04.02	1.01	1. Corrected header number of Uno Interface.
		2. Corrected the comment of Table 2-6.

Important Notice

Nuvoton Products are neither intended nor warranted for usage in systems or equipment, any malfunction or failure of which may cause loss of human life, bodily injury or severe property damage. Such applications are deemed, "Insecure Usage".

Insecure usage includes, but is not limited to: equipment for surgical implementation, atomic energy control instruments, airplane or spaceship instruments, the control or operation of dynamic, brake or safety systems designed for vehicular use, traffic signal instruments, all types of safety devices, and other applications intended to support or sustain life.

All Insecure Usage shall be made at customer's risk, and in the event that third parties lay claims to Nuvoton as a result of customer's Insecure Usage, customer shall indemnify the damages and liabilities thus incurred by Nuvoton.

*Please note that all data and specifications are subject to change without notice.
All the trademarks of products and companies mentioned in this datasheet belong to their respective owners.*