

Evaluation Board for the **ADF41020** PLL Frequency Synthesizer

FEATURES

Self-contained board for generating RF frequencies
 Contains the **ADF41020** 18 GHz frequency synthesizer IC
 Accompanying software allows complete control of synthesizer functions from a PC

EVALUATION KIT CONTENTS

EV-ADF41020EB1Z board

CD that includes

- Self-installing software that allows users to control the board and exercise all functions of the device
- Electronic version of the **ADF41020** data sheet
- Electronic version of the UG-405 user guide

ADDITIONAL EQUIPMENT

PC running Windows XP or more recent version
 Spectrum analyzer
 Oscilloscope (optional)
 Power supplies of 5.5 V and 15 V

DOCUMENTS NEEDED

ADF41020 data sheet

REQUIRED SOFTWARE

Analog Devices, Inc., Int-N software (Version 7 or higher)
ADIsimPLL™

GENERAL DESCRIPTION

The **EV-ADF41020EB1Z** evaluation board allows users to evaluate the performance of the **ADF41020** frequency synthesizer for phase-locked loops (PLLs). Figure 1 shows the board, which contains the **ADF41020** synthesizer, a 100 MHz TCXO, power supplies, a USB interface, and an RF output. There is also an active loop filter and a 12 GHz VCO on board. The evaluation kit contains software that is compatible with Windows® XP and later versions to allow easy programming of the synthesizer.

The USB interface allows software programming of the **ADF41020**. A USB cable is included with the board to allow software programmability.

Full specifications on the **ADF41020** are available in the **ADF41020** data sheet, which should be consulted in conjunction with this user guide when working with the evaluation board.

EVALUATION BOARD PHOTOGRAPH

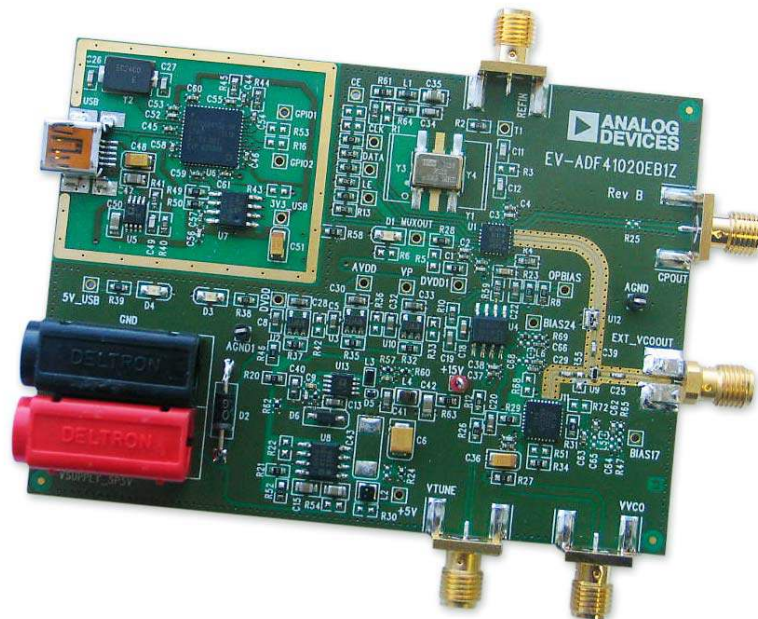

Figure 1. **EV-ADF41020EB1Z** Evaluation Board

TABLE OF CONTENTS

Features	1	Input Signals.....	4
Evaluation Kit Contents.....	1	Output Signals	4
Additional Equipment	1	Loop Filter	4
Documents Needed.....	1	Default Operation	4
Required Software	1	Evaluation Board Software.....	5
General Description	1	Evaluation and Test	7
Evaluation Board Photograph.....	1	Evaluation Board Schematics and Artwork.....	9
Revision History	2	Ordering Information.....	15
Quick Start Guide.....	3	Bill of Materials.....	15
Evaluation Board Hardware.....	4	Related Links.....	17
Power Supplies	4		

REVISION HISTORY

4/16—Rev. A to Rev. B

Change to Figure 9	10
Changes to Figure 11.....	12

1/15—Rev. 0 to Rev. A

Changes to General Description Section	1
Change to Loop Filter Section	4
Changes to Figure 5.....	6
Changes to Evaluation and Test Section and Figure 6.....	7
Changes to Figure 11	12
Changes to Table 2.....	16

12/12—Revision 0: Initial Version

QUICK START GUIDE

Use the following steps to evaluate the [ADF41020](#):

1. Install the Int-N software.
2. Follow the hardware driver installation procedure.
3. Connect the following power supplies to the [EV-ADF41020EB1Z](#).
 - a. Connect the 5.5 V power supply to the on-board banana connectors.
 - b. Connect the 15 V power supply to the test points labeled +15V and AGND.
4. Connect the USB cable to the PC and to the [EV-ADF41020EB1Z](#).
5. Run the Int-N software.
6. Select the [ADF41020](#) and the USB board in the **Select Device and Connection** tab of the software front panel window.
7. Ensure that the message **Board connected** appears on the front panel.
8. Click the **Main Controls** tab to input RF settings and settings.
9. Note that the **Phase Detector Polarity** drop-down list in the **Settings** section must be set to **Negative** to suit the active loop filter in inverting mode.
10. Update all registers.
11. Connect the EXT_VCOOUT output to a signal source analyzer.
12. Measure the results.

EVALUATION BOARD HARDWARE

The evaluation board comes with a USB cable to connect to the USB port of a PC. Figure 3 shows the evaluation board silkscreen. The EV-ADF41020EB1Z schematics are shown in Figure 8, Figure 9, Figure 10, and Figure 11.

POWER SUPPLIES

The board is powered via two external supplies, 5.5 V and 15 V, and connected as described in the Quick Start Guide section.

INPUT SIGNALS

The 100 MHz TCXO provides the necessary reference signal. An external REF_{IN} can be used if desired. A low noise, high slew rate reference source is best for achieving the stated performance of the ADF41020.

OUTPUT SIGNALS

The VCO output is available at EXT_VCOOUT through a standard SMA connector.

LOOP FILTER

An active loop filter using standard feedback is inserted between the charge pump output and the VCO input. Figure 2 shows the ADIsimPLL loop filter configuration. Table 1 shows how the ADIsimPLL loop filter component descriptors are related to the evaluation board descriptors in Figure 8, Figure 9, Figure 10, and Figure 11. Figure 3 shows the loop filter component placements.

The design parameters for the loop filter are for a center frequency of 12,000 MHz, a PFD frequency of 2.5 MHz, and

an active loop filter bandwidth of 30 kHz. To design a filter for different frequency setups, use the ADIsimPLL simulation software to generate filter component values and evaluate the results.

Table 1. Filter Components

ADIsimPLL	Evaluation Board
C1	C21
R1	R59
C2	C19
R2	R10
C3	C18
R3	R12
C4	C20

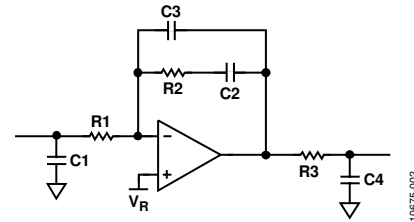

Figure 2. ADIsimPLL Filter

DEFAULT OPERATION

All components necessary for LO generation are inserted on the board. The board is shipped with the ADF41020 synthesizer, an active loop filter, and the VCO.

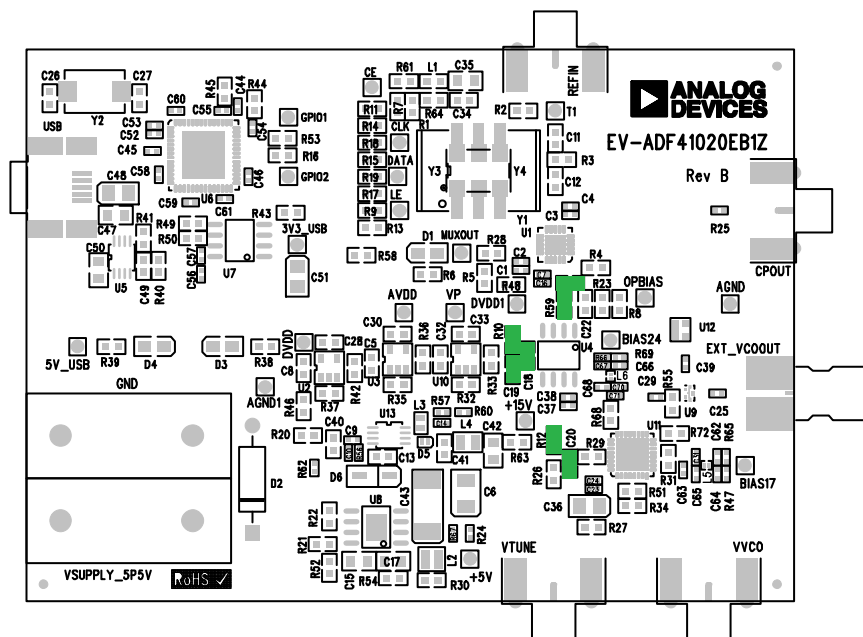

Figure 3. Evaluation Board Silkscreen

EVALUATION BOARD SOFTWARE

The control software for the [EV-ADF41020EB1Z](#) accompanies the [EV-ADF41020EB1Z](#) on a CD. For the software installation procedure, see [UG-476](#).

To run the software, click the **Int-N v7** file on the desktop or in the **Start** menu.

On the **Select Device and Connection** tab, choose your device and your connection method, and then click **Connect**.

Confirm that **Analog Devices RFG.I Eval Board connected** is displayed at the bottom left of the window (see Figure 4). Otherwise, the software has no connection to the evaluation board.

Note that, when connecting the board, it takes about 5 seconds to 10 seconds for the status label to change.

Under the **File** menu, the current settings can be saved to and loaded from a text file.

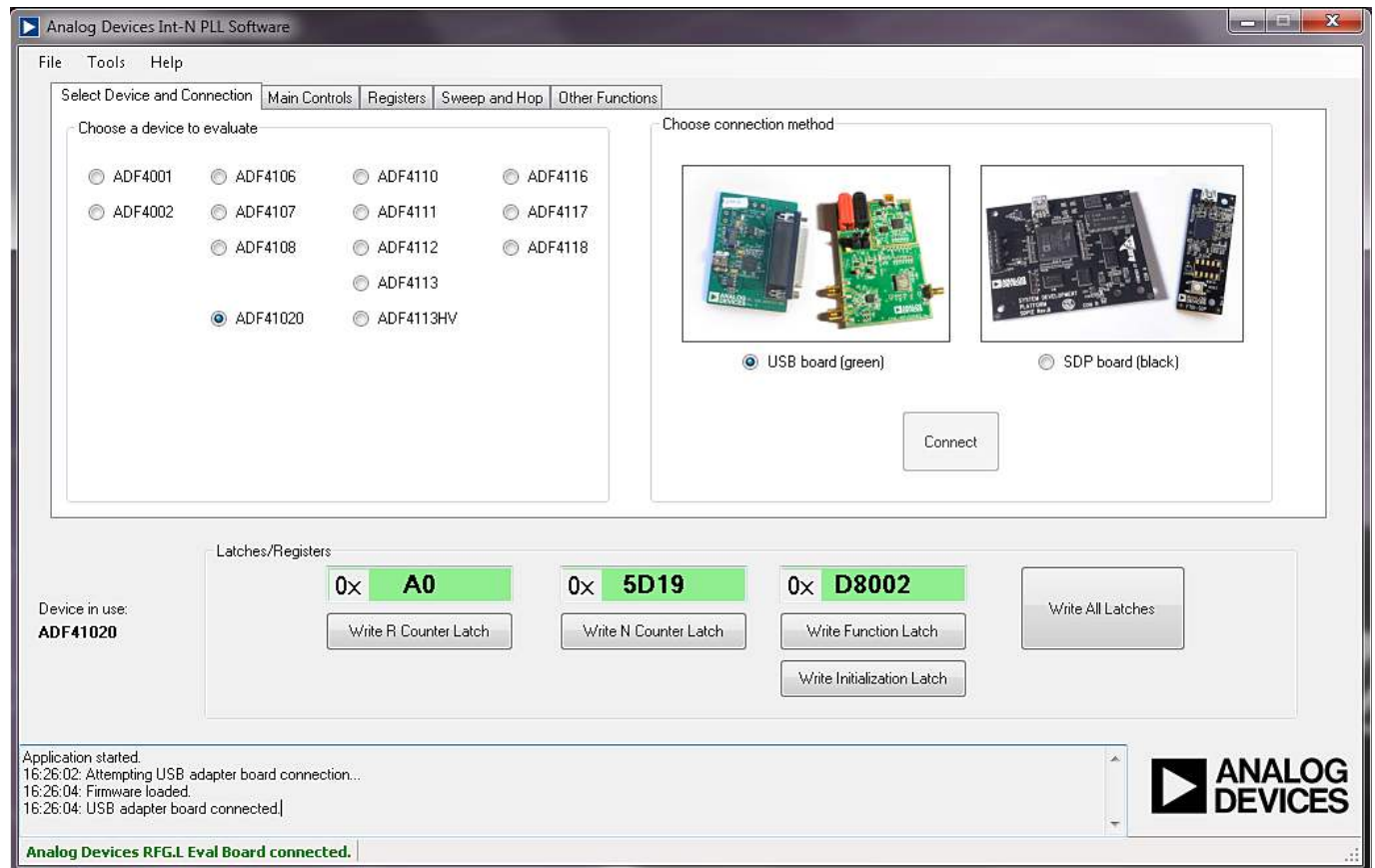

Figure 4. Software Front Panel Display—Select Device and Connection Tab

The **Main Controls** tab controls the PLL settings (see Figure 5).

Use the **Reference Frequency** text box to set the correct reference frequency and the reference frequency divider. The default reference on the software window is at 100 MHz.

Use the **RF Settings** section to control the output frequency. You can type the desired output frequency in the **RF VCO Output Frequency** text box (in MHz).

The **Settings** section lets you select general options available for the PLL, including the charge pump current settings and phase detector polarity. The **EV-ADF41020EB1Z** uses a charge pump setting of 2.5 mA and a negative phase detector polarity.

In the **Registers** tab, you can manually input the desired value to be written to the registers.

In the **Sweep and Hop** tab, you can make the device sweep a range of frequencies or hop between two set frequencies.

In the **Latches/Registers** section at the bottom of the window, the values to be written to each register are displayed. If the background on the text box is green, the value displayed is different from the value actually on the device. Click **Write R Counter Latch** or **Write N Counter Latch** to write that value to the device. To update all latches in the correct order, click **Write All Latches**.

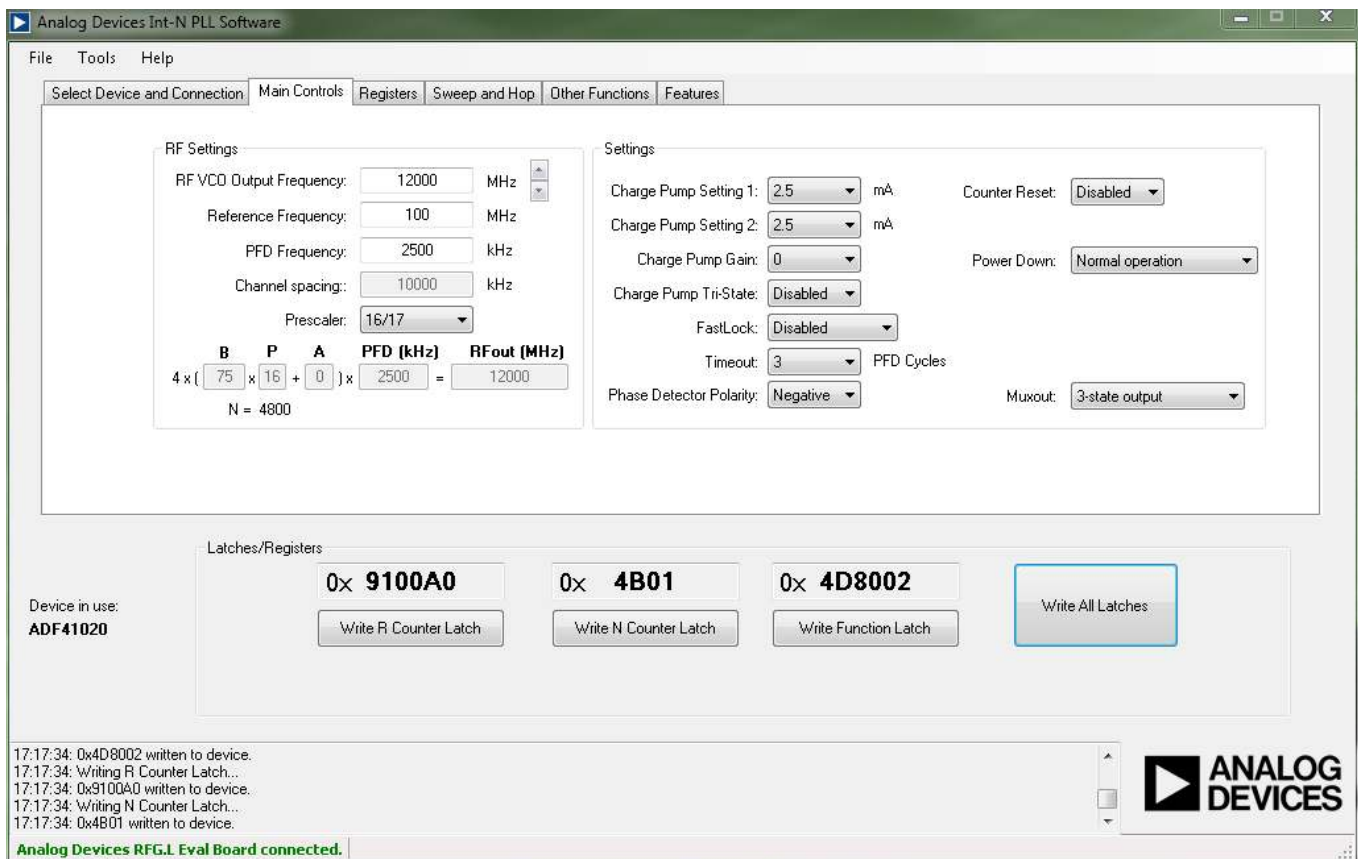

Figure 5. Software Front Panel Display—Main Controls Tab

EVALUATION AND TEST

To evaluate and test the performance of the [ADF41020](#), use the following steps:

1. Install the Analog Devices Int-N software.
2. Use [ADIsimPLL](#) to generate the loop filter component values if a different loop filter is required.
3. Solder new filter components specified by [ADIsimPLL](#).
4. Install the USB software drivers. Connect the evaluation board to a PC using the supplied USB cable. Follow the hardware driver installation procedure that appears.
5. Connect the USB connector to the [EV-ADF41020EB1Z](#).
6. Connect a spectrum analyzer to EXT_VCOOUT.
7. Run the Int-N software.
8. Select the USB board and the [ADF41020](#) device in the **Select Device and Connection** tab of the software front panel window. On the **Main Controls** tab, set the VCO center frequency (Figure 6 uses a 12 GHz VCO). Set the PFD frequency as specified in [ADIsimPLL](#), and program the reference frequency to 100 MHz. See Figure 7 for the suggested setup.
9. Measure the output spectrum. Figure 6 shows a 12 GHz output.

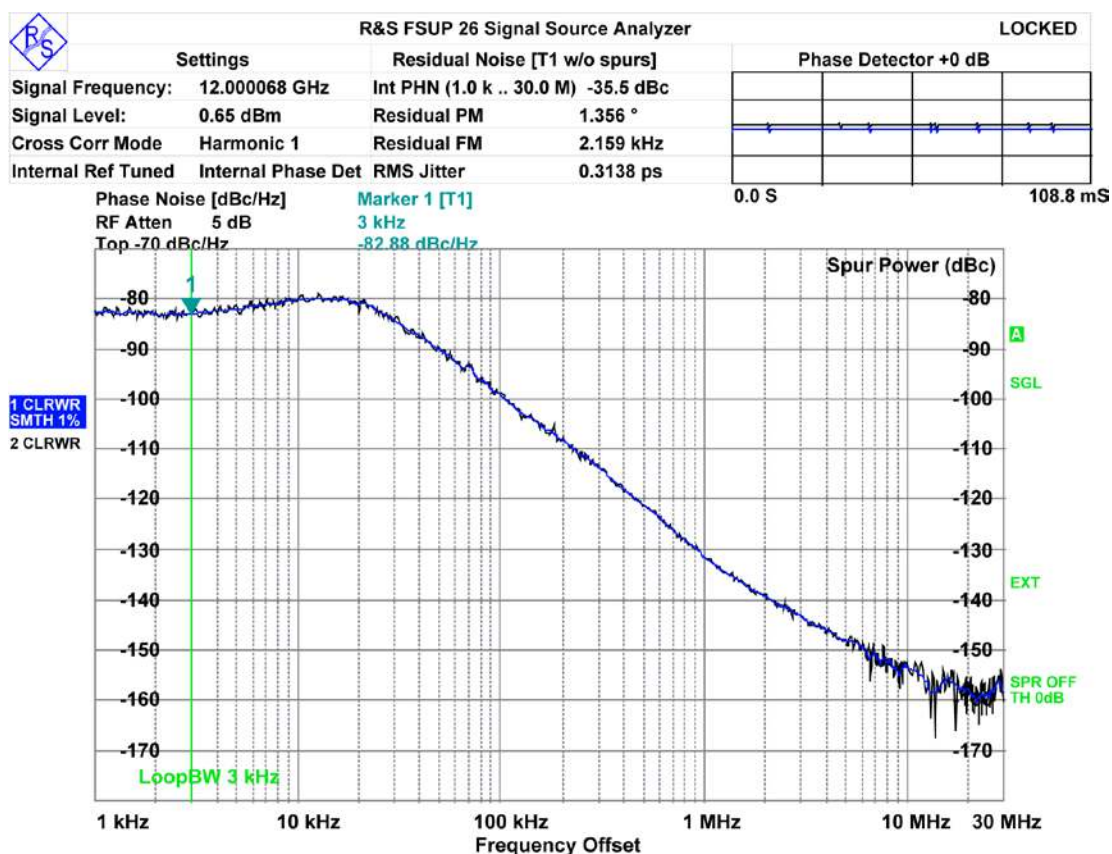

Figure 6. Spectrum Analyzer Display

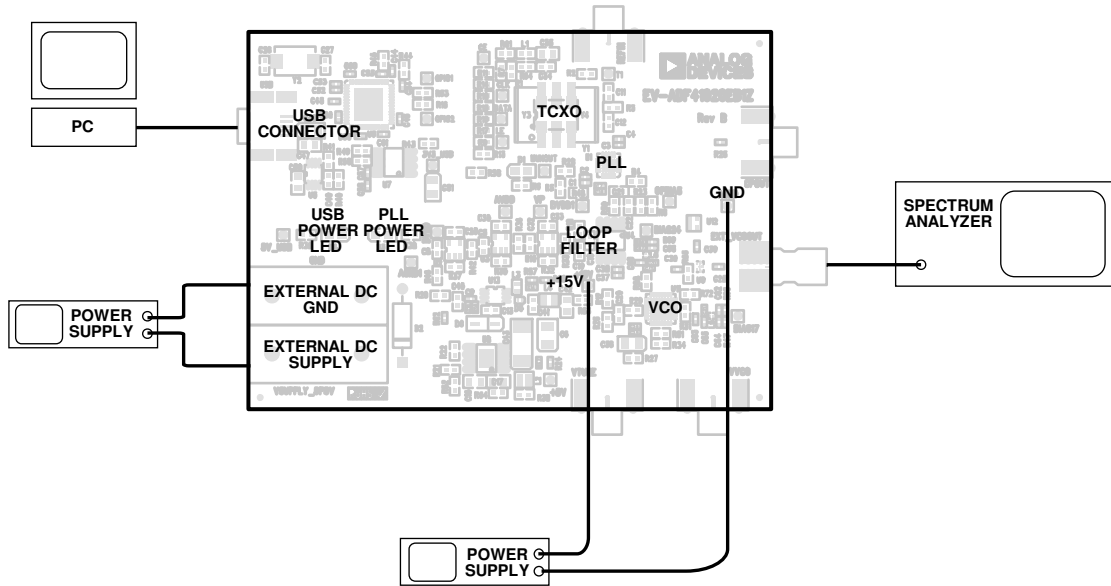

Figure 7. Typical Evaluation Setup

10675-021

EVALUATION BOARD SCHEMATICS AND ARTWORK

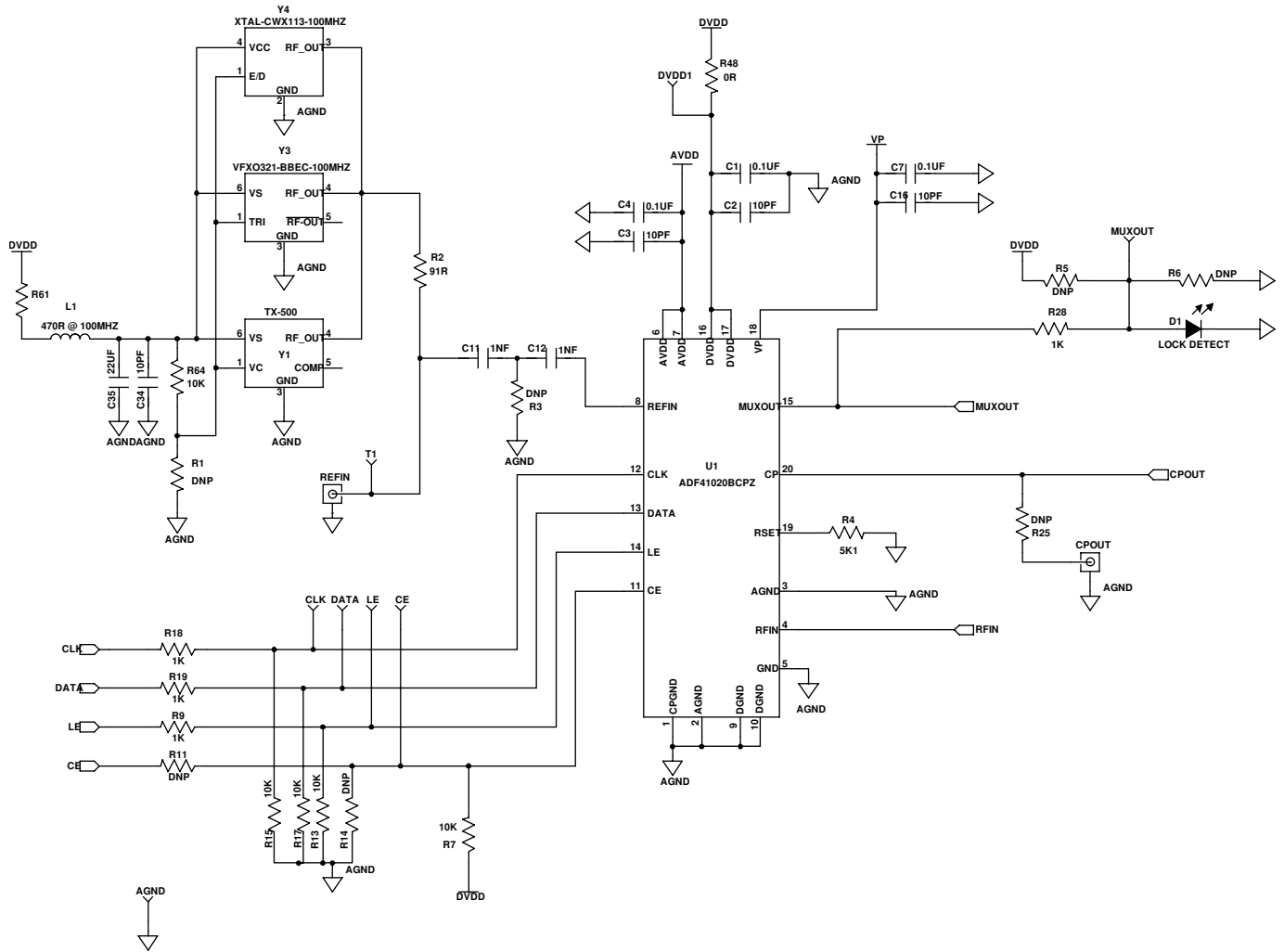

Figure 8. Evaluation Board Schematic (Page 1)

10675-022

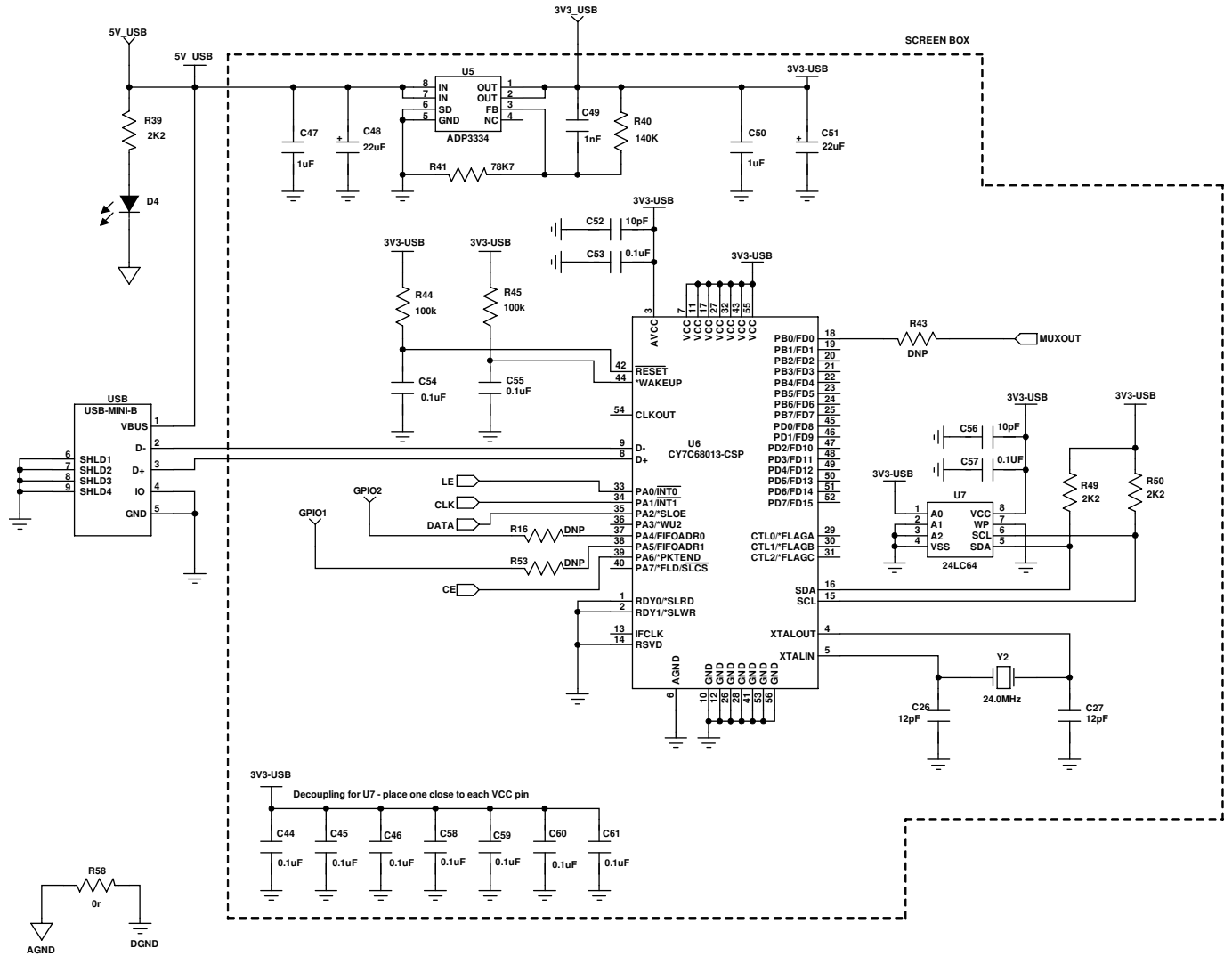

Figure 10. Evaluation Board Schematic (Page 3)

10675-024

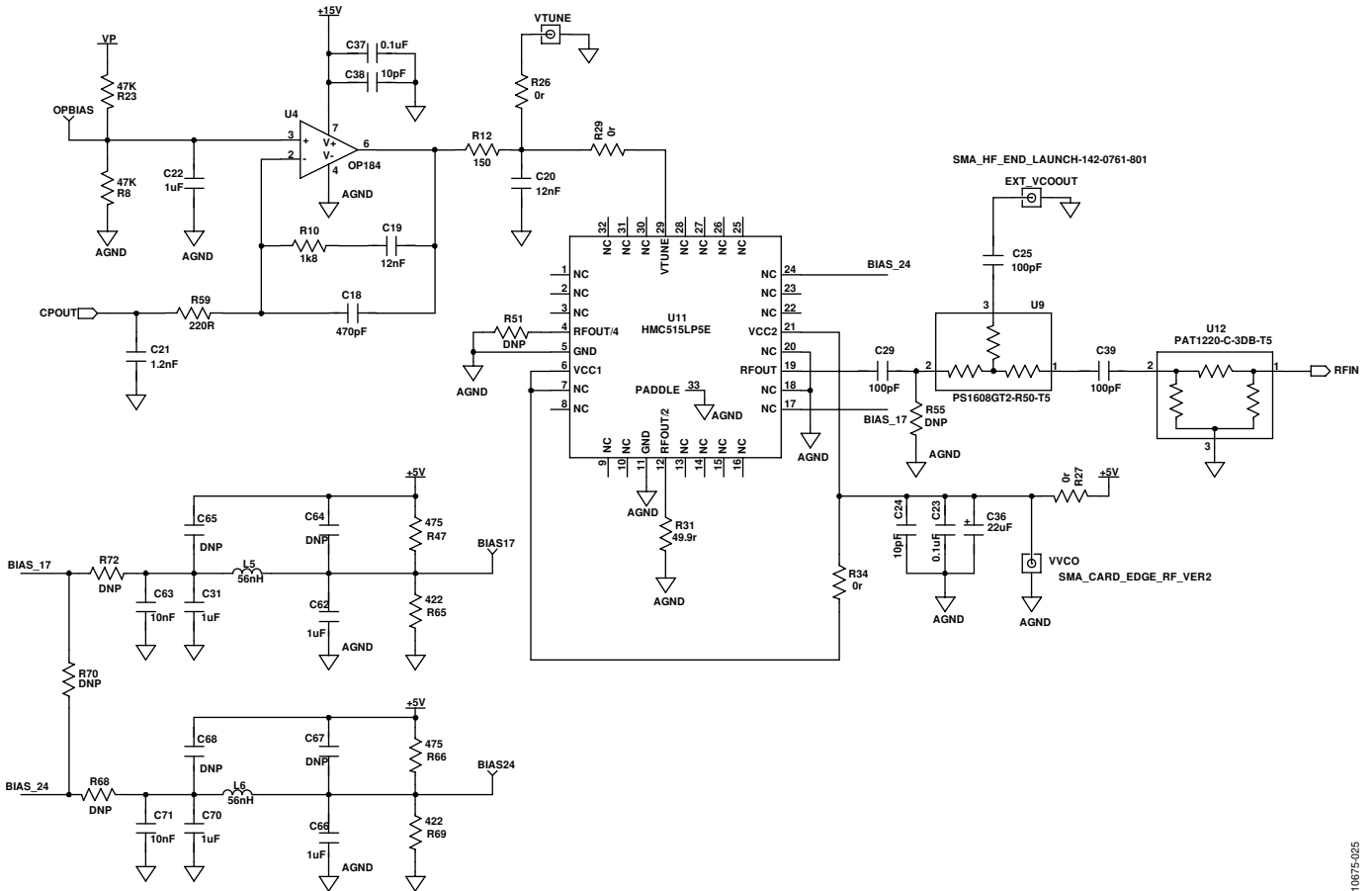
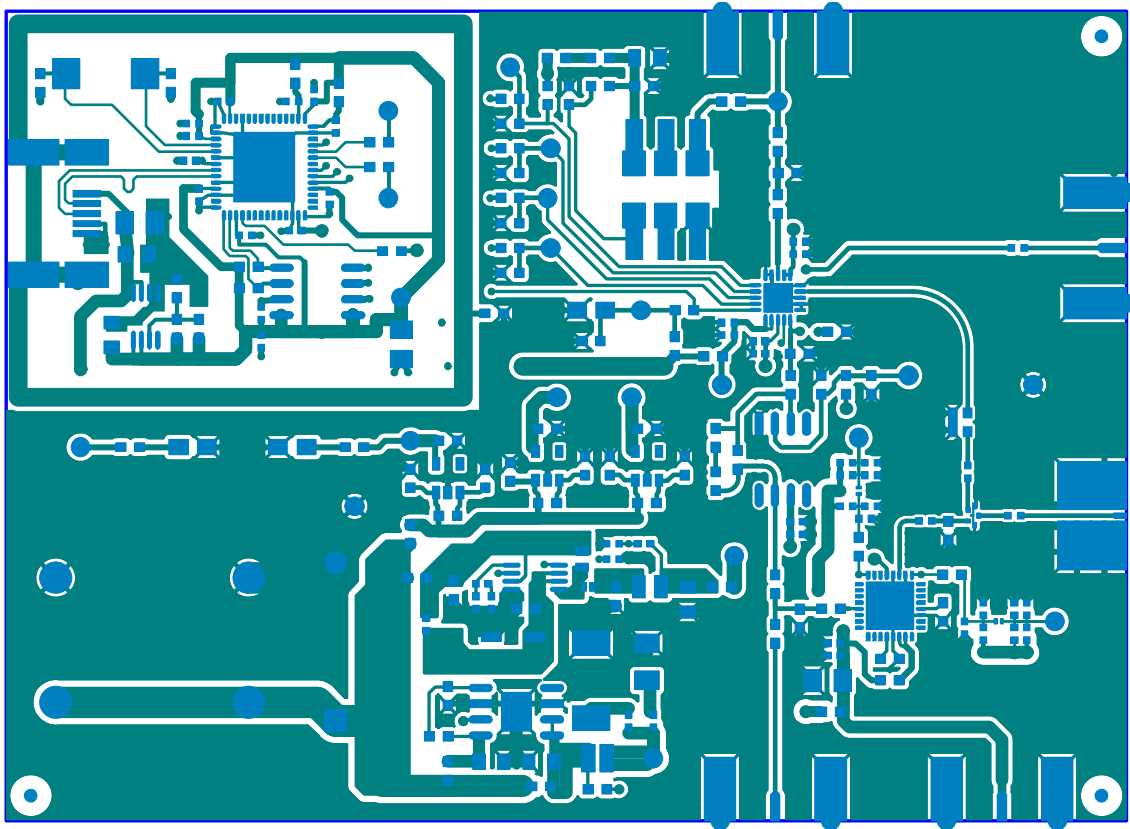

Figure 11. Evaluation Board Schematic (Page 4)

10875-025



10675-026

Figure 12. Layer 1 (Component Side)

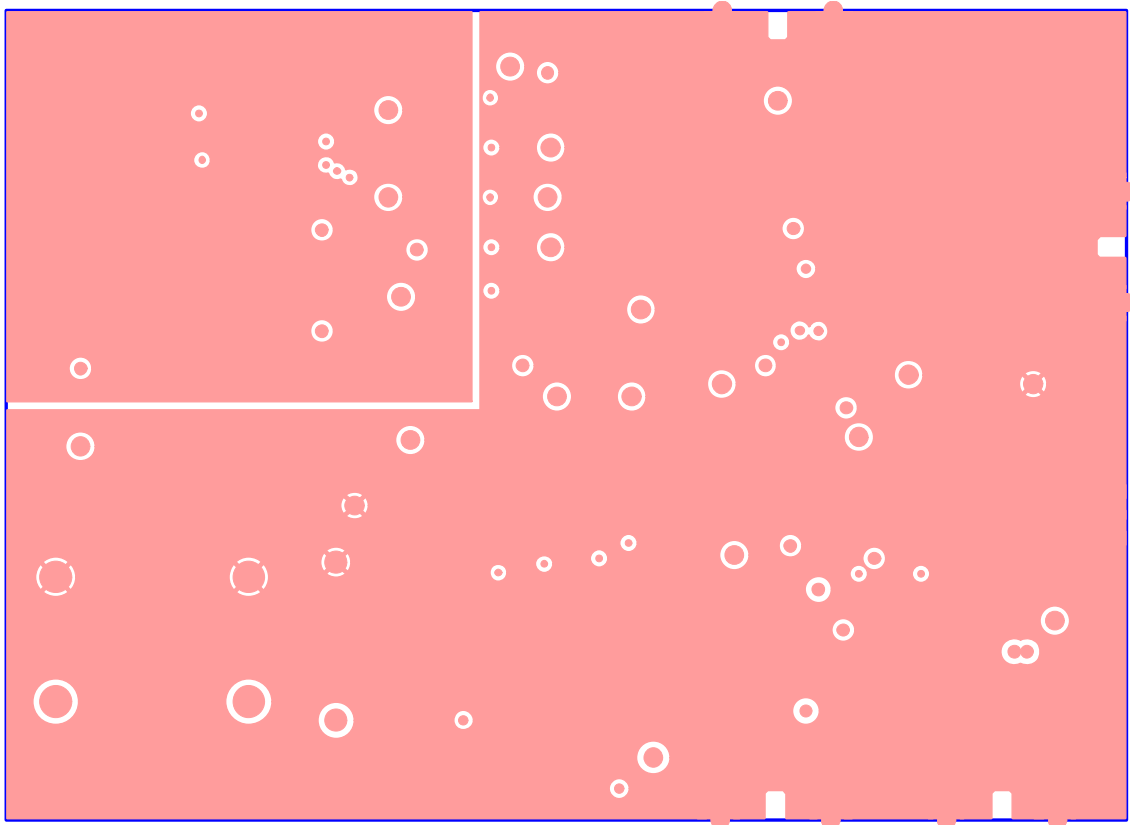

10675-027

Figure 13. Layer 2 (Ground Plane)

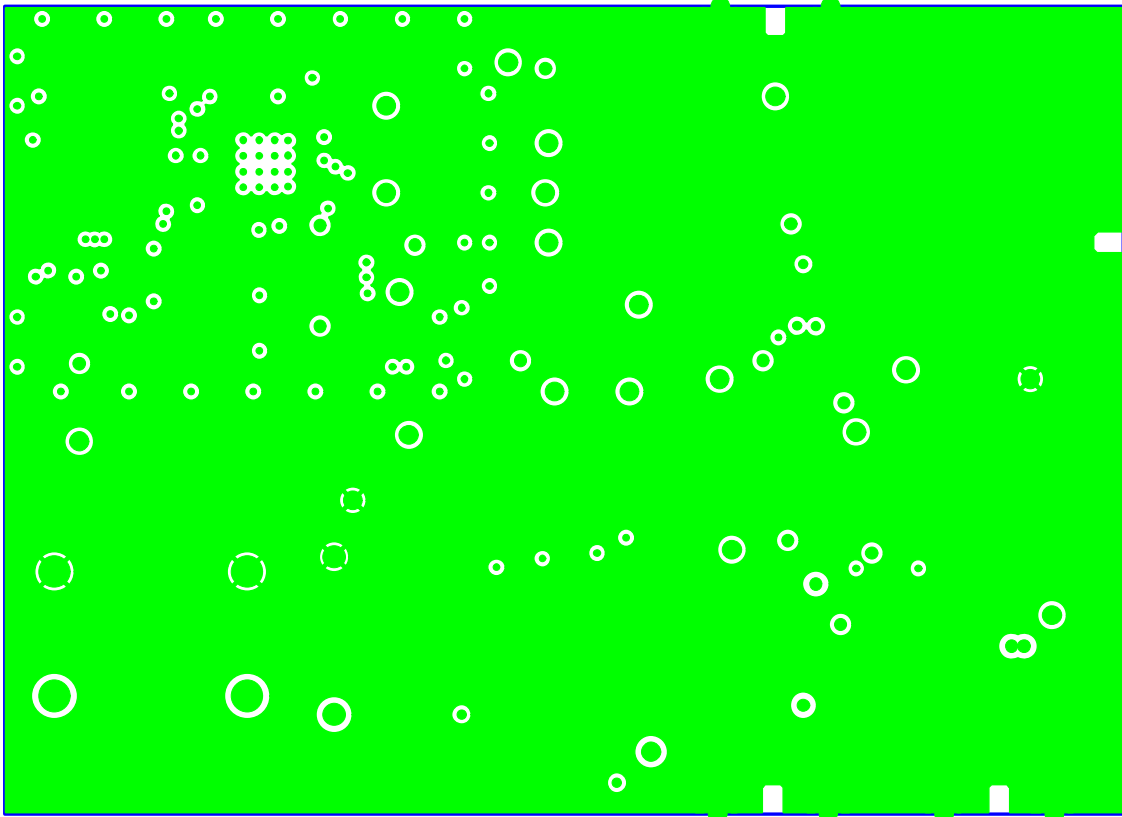

10675-028

Figure 14. Layer 3 (Power/Ground Plane)

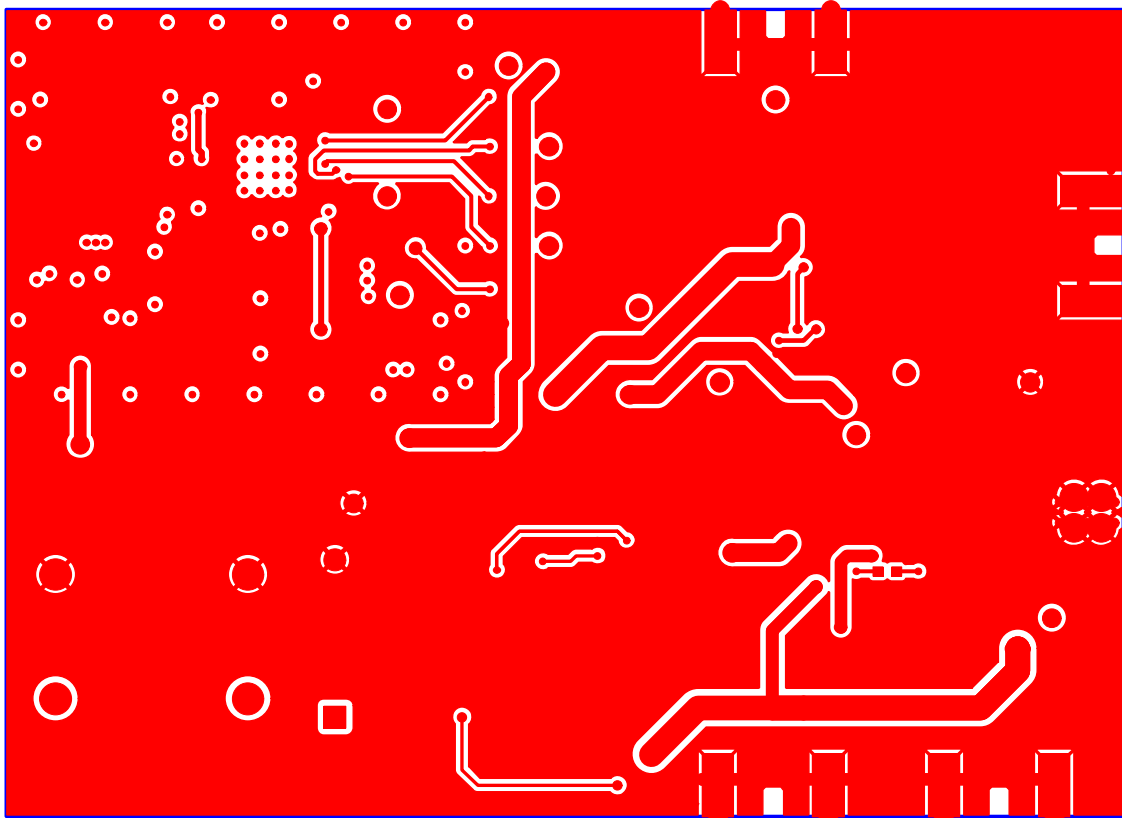

10675-029

Figure 15. Layer 4 (Solder Side)

ORDERING INFORMATION

BILL OF MATERIALS

Table 2.

Qty	Reference Designator	Part Description	Manufacturer	Part Number
1	+15V	Red test point	Vero	20-313137
2	AGND, AGND1	Black test point	Vero	20-2137
14	C1, C4, C7, C44, C45, C46, C53, C54, C55, C57, C58, C59, C60, C61	0.1 μ F, 0402, 16 V, X7R ceramic capacitor	Kemet	C0402C104K4RAC
3	C11, C12, C49	1 nF, 0603, 50 V, NPO ceramic capacitor	AVX	06035A102JAT2A
1	C14	10 nF, 10000 pF, 50 V, X7R, 0402 ceramic capacitor	Vishay	VJ0402Y103KNAAJ
4	C15, C42, C47, C50	1 μ F, 25 V, X5R, 0805 ceramic capacitor	Taiyo Yuden	TMK212BJ105KG-T
1	C17	10 μ F, 10 V, 10%, X5R, 0805 ceramic capacitor	Murata	GRM21BR61A106KE19L
1	C18	470 pF, MLCC, 0603, X7R, 50 V capacitor	Multicomp	MCCA000216
2	C19, C20	12 nF, MLCC, 0603, X7R, 25 V capacitor	Multicomp	MCCA000166
8	C2, C3, C10, C16, C24, C38, C52, C56	10 pF, 0402, 50 V, NPO ceramic capacitor	AVX	04025U100GAT2A
1	C21	1.2 nF, MLCC, 0603, X7R, 50 V capacitor	Multicomp	MCCA000226
2	C23, C37	0.1 μ F, 0402, 25 V, X5R ceramic capacitor	Taiyo Yuden	TMK105BJ104KV-F
3	C25, C29, C39	100 pF, 0402, 50 V, COG ceramic capacitor	Murata	GRM1555C1H101JD01D
2	C26, C27	12 pF, 0603, 50 V, NPO, SMD ceramic capacitor	Phycomp	2238 867 15129
4	C31, C62, C66, C70	1 μ F, 0402, 6.3 V, X5R ceramic capacitor	Murata	GRM155R60J105KE19D
1	C34	10 pF, 0603, multilayer ceramic capacitor	AVX	06035A100JAT2A
1	C35	22 μ F, 0805, 6.3 V, X5R ceramic capacitor	Murata	GRM21BR60J226ME39L
3	C36, C48, C51	22 μ F, RTAJ_A, 6.3 V tantalum capacitor (TAJ-A case)	AVX	TAJA226K006R
1	C40	1 μ F, 25 V, X5R, 0603 ceramic capacitor	Taiyo Yuden	TMK107BJ105KA-T
1	C41	0.1 μ F, 50 V, X7R, 0603 ceramic capacitor	Murata	GCM188R71H104KA57D
1	C43	DNP, RTAJ_D capacitor (not inserted)	N/A	N/A
8	C5, C8, C13, C22, C28, C30, C32, C33	1 μ F, 0603, 10 V, X5R capacitor	Murata	GRM188R61A105KA61D
1	C6	100 μ F RTAJ_B, Case B, 100 μ F, 6 V capacitor	Kemet	T520B107M006ATE040
2	C63, C71	10 nF, 0402, X7R, 16 V, 10 nF capacitor	Murata	GRM155R71C103KA01D
4	C64, C65, C67, C68	DNP 0402 capacitor location (not inserted)	N/A	N/A
1	C9	8200 pF, 50 V, X7R, 0402 ceramic capacitor	Vishay/ Vitramon	VJ0402Y822KNAAJ
4	CPOUT, REFIN, VTUNE, VVCO	SMA_CARD_EDGE_RF_VER2 connector jack end launch PC gold SMA	Emerson	142-0701-851
2	D1, D4	0805, green LED	Avago Technologies	HSMG-C170
1	D2	1 A, 50 V, DO41 standard diode	Multicomp	1N4001
1	D3	0805, red LED	Avago Technologies	HSMS-C170
1	D5	2-XFDFN, Schottky diode, 30 V, 2-DFN	Diodes Inc.	BAT54LP-7
1	D6	5.1 V, 500 MW, SOD-123 Zener diode	Diodes Inc	DDZ9689
1	EXT_VCOOUT	High frequency SMA end launch connector	Emerson (Johnson)	142-0761-801
1	GND	Black 4 mm banana socket	Deltron	571-0100-01
1	L1	470 Ω at 100 MHz L0603 ferrite bead	Wuerth Elektronik	7427-92642
1	L2	4.7 μ H, EPL2014-472ML inductor, SMT power EPL2014 series	Coilcraft	EPL2014-472ML
1	L3	4.7 μ H, PFL1610-472MEU inductor, SMT PFL1610 series shielded power inductor	Coilcraft	PFL1610-472MEU
1	L4	0805LS-111, 110 nH, chip, 0805LS (2012) inductor	Coilcraft	0805LS-111
2	L5, L6	56 nH, L0201, 0201 case inductor	Murata	LQP03TN56NJ04D

Qty	Reference Designator	Part Description	Manufacturer	Part Number
24	R1, R14, R54, R3, R5, R6, R11, R16, R20, R22, R25, R30, R33, R36, R42, R43, R51, R53, R55, R63, R67, R68, R70, R72	DNP, R0603 0603 location resistor (not inserted)	Not applicable	Not applicable
1	R10	1.8 k Ω , 0603 resistor	Multicomp	MC 0.063W 0603 1% 1k8
1	R12	150 Ω , 0603 resistor	Multicomp	MC 0.063W 0603 1% 150
1	R2	91 Ω , 0603, SMD resistor	Multicomp	MC 0.063W 0603 1% 91R
12	R21, R26, R27, R29, R32, R34, R35, R37, R48, R52, R58, R61	0 Ω , 0603, SMD resistor	Multicomp	MC 0.063W 0603 0R
1	R24	0.33 Ω , 1%, 0402 resistor	Welwyn	LRCS0402-0R33FT5
1	R31	49.9 Ω , 0603, 1% resistor	Vishay Draloric	CRCW060349R9FKEA
3	R39, R49, R50	2.2 k Ω , 0603 SMD resistor	Multicomp	MC 0.063W 0603 2k2
1	R4	5.1 k Ω , 0603 SMD resistor	Multicomp	MC 0.063W 0603 5k1
1	R40	140 k Ω 0603 SMD resistor	Multicomp	MC 0.063W 0603 1% 140K
1	R41	78.7 k Ω , 0603, SMD resistor	Multicomp	MC 0.063W 0603 1% 78K7
2	R44, R45	100 k Ω , 0603, SMD resistor	Multicomp	MC 0.063W 0603 100K
1	R46	10 Ω , 0603, SMD resistor	Multicomp	MC 0.063W 0603 10R
2	R47, R66	475 Ω , 0402, 1% resistor	Multicomp	MC 0.0625W 0402 1% 475R
1	R56	61.9 k Ω , 1/16 W, 1%, 0402, SMD resistor	Vishay	CRCW040261K9FKED
1	R57	14.7 k Ω , 1/16 W, 1%, 0402 SMD resistor	Vishay	CRCW040214K7FKED
1	R59	220 Ω , 0603 resistor	Multicomp	MC 0.063W 0603 1% 220R
1	R60	165 k Ω , 0402, 1/16 W, 1%, SMD resistor	Vishay	CRCW0402165KFKED
1	R62	48.7 Ω , 0402, 1/16 W, 1%, SMD resistor	Vishay	CRCW040248R7FKED
2	R65, R69	422 Ω , 0402, 1% resistor	Multicomp	MC 0.0625W 0402 1% 422R
5	R7, R13, R15, R17, R64	10 k Ω , 0603, SMD resistor	Multicomp	MC 0.063W 0603 10K
2	R8, R23	47 k Ω , 0603, 1% resistor	Multicomp	MC0603WGF4702T5E-TC
5	R9, R18, R19, R28, R38	1 k Ω , 0603, 1% resistor	Multicomp	MC 0.063W 0603 1K
1	U1	LFCSP-20-6, PLL frequency synthesizer	Analog Devices	ADF41020BCPZ
1	U11	LFCSP-32, VCO SMT with $f_0/2$ and divide by 4, 11.5 GHz to 12.5 GHz	Analog Devices	HMC515LP5E
1	U12	3 dB, 50 Ω , 0805, SMD attenuator	Susumu Co. Ltd	PAT1220-C-3DB-T5
1	U13	MSO8 650 kHz /1.3 MHz step-up PWM dc-to-dc switching converters	Analog Devices	ADP1613ARMZ
3	U2, U3, U10	TSOT-5, 3.0 V, linear regulator	Analog Devices	ADP150AUJZ-3.0
1	U4	SO8NB single op amp	Analog Devices	OP184ESZ
1	U5	MSO8 adjustable LDO regulator	Analog Devices	ADP3334ARMZ
1	U6	LFCSP-56_RP USB microcontroller	Cypress Semiconductor	CY7C68013A-56LFXC
1	U7	SO8NB 64K I ² C serial EEPROM	Microchip Technology	24LC64-ISN
1	U8	SO8NB_RD8-2 20 V, 500 mA, low noise, CMOS adjustable LDO	Analog Devices	ADP7104ARDZ
1	U9	6 dB, 0.1 W, 0603, SMD power divider	Susumu Co. Ltd	PS1608GT2-R50-T5
1	USB	USB mini-B connector (USB-otg)	Molex	54819-0578
1	VSUPPLY_5P5V	Red, 4 mm, banana socket	Deltron	571-0500-01
1	Y2	XTAL1-CSM-8A, 24.0 MHz, SMD crystal	ECS International	ECS-240-12-20A-TR
1	Y4	100 MHz, XTAL_CWX813, OSC, 3.3 V, ± 25 ppm, SMD (5 mm \times 7 mm)	Connor-Winfield	CWX113-100.0M

RELATED LINKS

Resource	Description
ADF41020	Product Page, 18 GHz PLL Frequency Synthesizer
ADP150	Product Page, Ultralow Noise, 150 mA CMOS Linear Regulator
OP184	Product Page, Single-Supply Rail-to-Rail Input/Output Operational Amplifier
ADP3334	Product Page, High Accuracy Low IQ, 500 mA anyCAP® Adjustable Low Dropout Regulator
ADP7104	Product Page, 20 V, 500 mA, Low Noise, CMOS LDO

I²C refers to a communications protocol originally developed by Philips Semiconductors (now NXP Semiconductors).

**ESD Caution**

ESD (electrostatic discharge) sensitive device. Charged devices and circuit boards can discharge without detection. Although this product features patented or proprietary protection circuitry, damage may occur on devices subjected to high energy ESD. Therefore, proper ESD precautions should be taken to avoid performance degradation or loss of functionality.

Legal Terms and Conditions

By using the evaluation board discussed herein (together with any tools, components documentation or support materials, the "Evaluation Board"), you are agreeing to be bound by the terms and conditions set forth below ("Agreement") unless you have purchased the Evaluation Board, in which case the Analog Devices Standard Terms and Conditions of Sale shall govern. Do not use the Evaluation Board until you have read and agreed to the Agreement. Your use of the Evaluation Board shall signify your acceptance of the Agreement. This Agreement is made by and between you ("Customer") and Analog Devices, Inc. ("ADI"), with its principal place of business at One Technology Way, Norwood, MA 02062, USA. Subject to the terms and conditions of the Agreement, ADI hereby grants to Customer a free, limited, personal, temporary, non-exclusive, non-sublicensable, non-transferable license to use the Evaluation Board FOR EVALUATION PURPOSES ONLY. Customer understands and agrees that the Evaluation Board is provided for the sole and exclusive purpose referenced above, and agrees not to use the Evaluation Board for any other purpose. Furthermore, the license granted is expressly made subject to the following additional limitations: Customer shall not (i) rent, lease, display, sell, transfer, assign, sublicense, or distribute the Evaluation Board; and (ii) permit any Third Party to access the Evaluation Board. As used herein, the term "Third Party" includes any entity other than ADI, Customer, their employees, affiliates and in-house consultants. The Evaluation Board is NOT sold to Customer; all rights not expressly granted herein, including ownership of the Evaluation Board, are reserved by ADI. CONFIDENTIALITY. This Agreement and the Evaluation Board shall all be considered the confidential and proprietary information of ADI. Customer may not disclose or transfer any portion of the Evaluation Board to any other party for any reason. Upon discontinuation of use of the Evaluation Board or termination of this Agreement, Customer agrees to promptly return the Evaluation Board to ADI. ADDITIONAL RESTRICTIONS. Customer may not disassemble, decompile or reverse engineer chips on the Evaluation Board. Customer shall inform ADI of any occurred damages or any modifications or alterations it makes to the Evaluation Board, including but not limited to soldering or any other activity that affects the material content of the Evaluation Board. Modifications to the Evaluation Board must comply with applicable law, including but not limited to the RoHS Directive. TERMINATION. ADI may terminate this Agreement at any time upon giving written notice to Customer. Customer agrees to return to ADI the Evaluation Board at that time. LIMITATION OF LIABILITY. THE EVALUATION BOARD PROVIDED HEREUNDER IS PROVIDED "AS IS" AND ADI MAKES NO WARRANTIES OR REPRESENTATIONS OF ANY KIND WITH RESPECT TO IT. ADI SPECIFICALLY DISCLAIMS ANY REPRESENTATIONS, ENDORSEMENTS, GUARANTEES, OR WARRANTIES, EXPRESS OR IMPLIED, RELATED TO THE EVALUATION BOARD INCLUDING, BUT NOT LIMITED TO, THE IMPLIED WARRANTY OF MERCHANTABILITY, TITLE, FITNESS FOR A PARTICULAR PURPOSE OR NON-INFRINGEMENT OF INTELLECTUAL PROPERTY RIGHTS. IN NO EVENT WILL ADI AND ITS LICENSORS BE LIABLE FOR ANY INCIDENTAL, SPECIAL, INDIRECT, OR CONSEQUENTIAL DAMAGES RESULTING FROM CUSTOMER'S POSSESSION OR USE OF THE EVALUATION BOARD, INCLUDING BUT NOT LIMITED TO LOST PROFITS, DELAY COSTS, LABOR COSTS OR LOSS OF GOODWILL. ADI'S TOTAL LIABILITY FROM ANY AND ALL CAUSES SHALL BE LIMITED TO THE AMOUNT OF ONE HUNDRED US DOLLARS (\$100.00). EXPORT. Customer agrees that it will not directly or indirectly export the Evaluation Board to another country, and that it will comply with all applicable United States federal laws and regulations relating to exports. GOVERNING LAW. This Agreement shall be governed by and construed in accordance with the substantive laws of the Commonwealth of Massachusetts (excluding conflict of law rules). Any legal action regarding this Agreement will be heard in the state or federal courts having jurisdiction in Suffolk County, Massachusetts, and Customer hereby submits to the personal jurisdiction and venue of such courts. The United Nations Convention on Contracts for the International Sale of Goods shall not apply to this Agreement and is expressly disclaimed.

©2012–2016 Analog Devices, Inc. All rights reserved. Trademarks and registered trademarks are the property of their respective owners.
UG10675-0-4/16(B)



www.analog.com