

XC835/836

8-Bit Single-Chip Microcontroller

Data Sheet

V1.4 2011-10

Microcontrollers

Edition 2011-10

**Published by
Infineon Technologies AG
81726 Munich, Germany**

**© 2011 Infineon Technologies AG
All Rights Reserved.**

Legal Disclaimer

The information given in this document shall in no event be regarded as a guarantee of conditions or characteristics. With respect to any examples or hints given herein, any typical values stated herein and/or any information regarding the application of the device, Infineon Technologies hereby disclaims any and all warranties and liabilities of any kind, including without limitation, warranties of non-infringement of intellectual property rights of any third party.

Information

For further information on technology, delivery terms and conditions and prices, please contact the nearest Infineon Technologies Office (www.infineon.com).

Warnings

Due to technical requirements, components may contain dangerous substances. For information on the types in question, please contact the nearest Infineon Technologies Office.

Infineon Technologies components may be used in life-support devices or systems only with the express written approval of Infineon Technologies, if a failure of such components can reasonably be expected to cause the failure of that life-support device or system or to affect the safety or effectiveness of that device or system. Life support devices or systems are intended to be implanted in the human body or to support and/or maintain and sustain and/or protect human life. If they fail, it is reasonable to assume that the health of the user or other persons may be endangered.

XC835/836

8-Bit Single-Chip Microcontroller

Data Sheet

V1.4 2011-10

Microcontrollers

XC835/836 Data Sheet**Revision History: V1.4 2011-10**

Previous Versions: V 1.2

Page	Subjects (major changes since last revision)
Page 3	Added a new variant (SAF-XC836-2FRA) in Table 2.
Page 24	Added the SAK temperature range in Table 7.
Page 21	Updated the Chip Identification number in Table 5.

We Listen to Your Comments

Is there any information in this document that you feel is wrong, unclear or missing?
Your feedback will help us to continuously improve the quality of this document.
Please send your proposal (including a reference to this document) to:

mcdocu.comments@infineon.com



Table of Contents

1	Summary of Features	1
2	General Device Information	5
2.1	Block Diagram	5
2.2	Logic Symbol	6
2.3	Pin Configuration	7
2.4	Pin Definitions and Functions	9
2.5	Memory Organization	18
2.6	JTAG ID	20
2.7	Chip Identification Number	21
3	Electrical Parameters	22
3.1	General Parameters	22
3.1.1	Parameter Interpretation	22
3.1.2	Absolute Maximum Rating	23
3.1.3	Operating Condition	24
3.2	DC Parameters	25
3.2.1	Input/Output Characteristics	25
3.2.2	Supply Threshold Characteristics	28
3.2.3	ADC Characteristics	29
3.2.3.1	ADC Conversion Timing	32
3.2.3.2	Out of Range Comparator Characteristics	32
3.2.4	Flash Memory Parameters	33
3.2.5	Power Supply Current	35
3.3	AC Parameters	38
3.3.1	Testing Waveforms	38
3.3.2	Output Rise/Fall Times	39
3.3.3	Oscillator Timing and Wake-up Timing	40
3.3.4	On-Chip Oscillator Characteristics	41
3.3.5	SSC Timing	43
3.3.5.1	SSC Master Mode Timing	43
3.3.5.2	SSC Slave Mode Timing	44
3.3.6	SPD Timing	45
4	Package and Quality Declaration	46
4.1	Package Parameters	46
4.2	Package Outline	47
4.3	Quality Declaration	50

1 Summary of Features

The XC835/836 has the following features:

- High-performance XC800 Core
 - compatible with standard 8051 processor
 - two clocks per machine cycle architecture (for memory access without wait state)
 - two data pointers
- On-chip memory
 - 8 Kbytes of Boot ROM, Library ROM and User routines
 - 256 bytes of RAM
 - 256 bytes of XRAM
 - 4/8 Kbytes of Flash (includes memory protection strategy)
- I/O port supply at 2.5 V - 5.5 V and core logic supply at 2.5 V (generated by embedded voltage regulator)

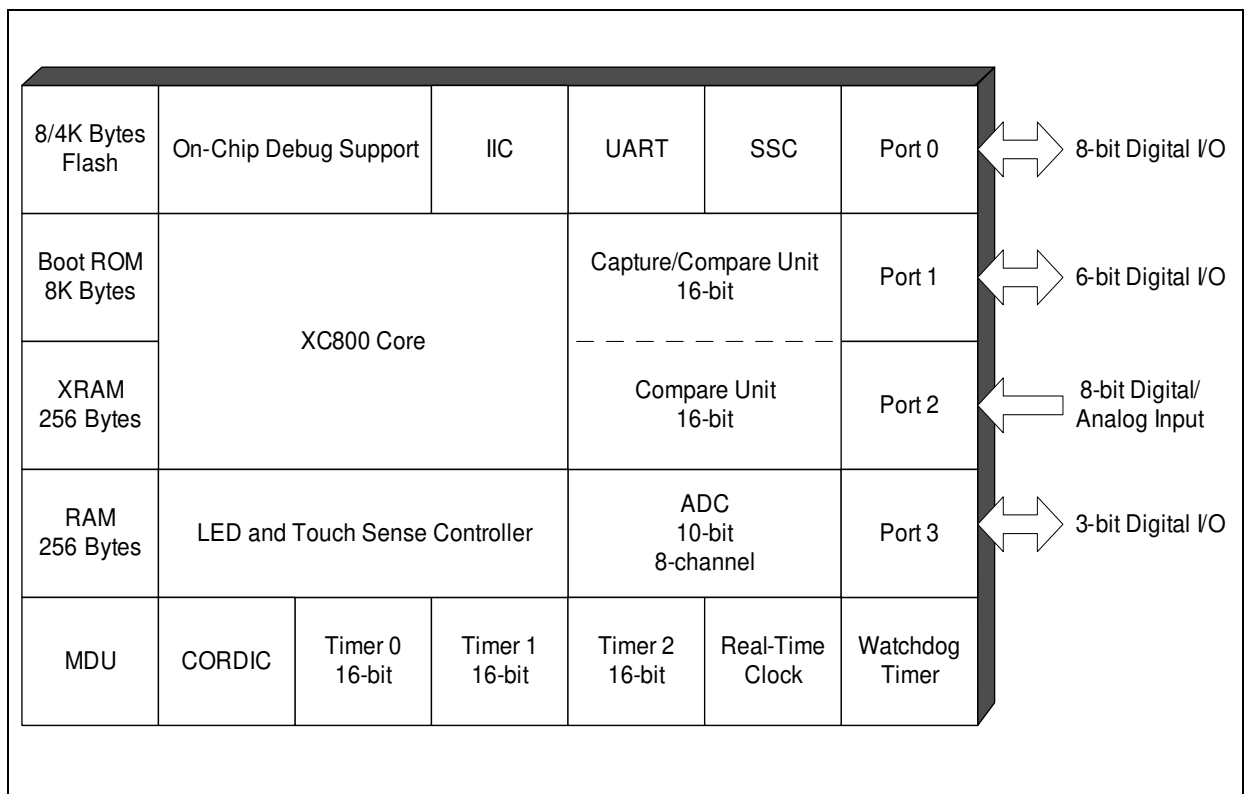

Figure 1 XC835/836 Functional Units

- Power-on reset generation
- Brownout detection for IO supply and core logic supply
- 48 MHz on-chip OSC for clock generation
 - Loss-of-Clock detection

(more features on next page)

Summary of Features

Features: (continued)

- Power saving modes
 - idle mode
 - power-down mode with wake-up capability via real-time clock event
 - clock gating control to each peripheral
- Programmable 16-bit Watchdog Timer (WDT) running on independent oscillator with programmable window feature for refresh operation and warning prior to overflow
- Three general purpose I/O ports
 - 4 high current I/O
 - 2 high sink I/O
 - Up to 25 pins as digital I/O
 - Up to 8 pins as digital/analog input
- Up to 8 channels, 10-bit A/D Converter
 - support up to 7 differential input channel
 - results filtering by data reduction or digital low-pass filter, for up to 13-bit results
- Up to 8 channels, Out of range comparator
- Three 16-bit timers
 - Timer 0 and Timer 1 (T0 and T1)
 - Timer 2 (T2)
- Real-time clock with 32.768 kHz crystal pad
- 16-bit Vector Computer for Field-Oriented Control (FOC)
 - Multiplication/Division Unit (MDU) for arithmetic calculation
 - CORDIC Unit for trigonometric calculation
- Capture and Compare unit for PWM signal generation (CCU6)
- A full-duplex or half-duplex serial interface (UART)
- Synchronous serial channel (SSC)
- Inter-IC (IIC) serial interface
- LED and Touch-sense Controller (LEDTSCU)
- Software libraries to support fixed-point control and EEPROM emulation
- On-chip debug support via single pin DAP interface (SPD)
- Packages:
 - PG-DSO-24
 - PG-TSSOP-28
- Temperature range T_A :
 - SAF (-40 to 85 °C)
 - SAK (-40 to 125 °C)

Summary of Features
XC835/836 Variant Devices

The XC835/836 product family features devices with different configurations, program memory sizes, packages options and temperature profiles, to offer cost-effective solutions for different application requirements.

The list of XC835/836 device configurations are summarized in **Table 1**. The type of packages available are DSO-24 for XC835 and TSSOP-28 for XC836.

Table 1 Device Configuration

Device Name	MDU and CORDIC Module	LEDTSCU Module
XC835/836	No	No
XC835/836M	Yes	No
XC835/836T	No	Yes
XC835/836MT	Yes	Yes

Table 2 shows the device sales type available, based on above device.

Table 2 Device Profile

Sales Type	Device Type	Program Memory (Kbytes)	Temperature Profile (°C)	Package Type	Quality Profile
SAF-XC835MT-2FGI	Flash	8	-40 to 85	PG-DSO-24-1	Industrial
SAF-XC836-2FRI	Flash	8	-40 to 85	PG-TSSOP-28-1	Industrial
SAF-XC836T-2FRI	Flash	8	-40 to 85	PG-TSSOP-28-1	Industrial
SAF-XC836M-2FRI	Flash	8	-40 to 85	PG-TSSOP-28-1	Industrial
SAF-XC836M-1FRI	Flash	4	-40 to 85	PG-TSSOP-28-1	Industrial
SAF-XC836MT-2FRI	Flash	8	-40 to 85	PG-TSSOP-28-1	Industrial
SAF-XC836-2FRA	Flash	8	-40 to 85	PG-TSSOP-28-12	Automotive
SAF-XC836MT-2FRA	Flash	8	-40 to 85	PG-TSSOP-28-12	Automotive
SAF-XC836MT-1FRA	Flash	4	-40 to 85	PG-TSSOP-28-12	Automotive
SAK-XC836MT-2FRA	Flash	8	-40 to 125	PG-TSSOP-28-12	Automotive
SAK-XC836MT-1FRA	Flash	4	-40 to 125	PG-TSSOP-28-12	Automotive

As this document refers to all the derivatives, some description may not apply to a specific product. For simplicity, all versions are referred to by the term XC835/836 throughout this document.

Summary of Features

Ordering Information

The ordering code for Infineon Technologies microcontrollers provides an exact reference to the required product. This ordering code identifies:

- The derivative itself, i.e. its function set, the temperature range, and the supply voltage
- The package and the type of delivery

For the available ordering codes for the XC835/836, please refer to your responsible sales representative or your local distributor.

2 General Device Information

Chapter 2 contains the block diagram, pin configurations, definitions and functions of the XC835/836.

2.1 Block Diagram

The block diagram of the XC835/836 is shown in **Figure 2**.

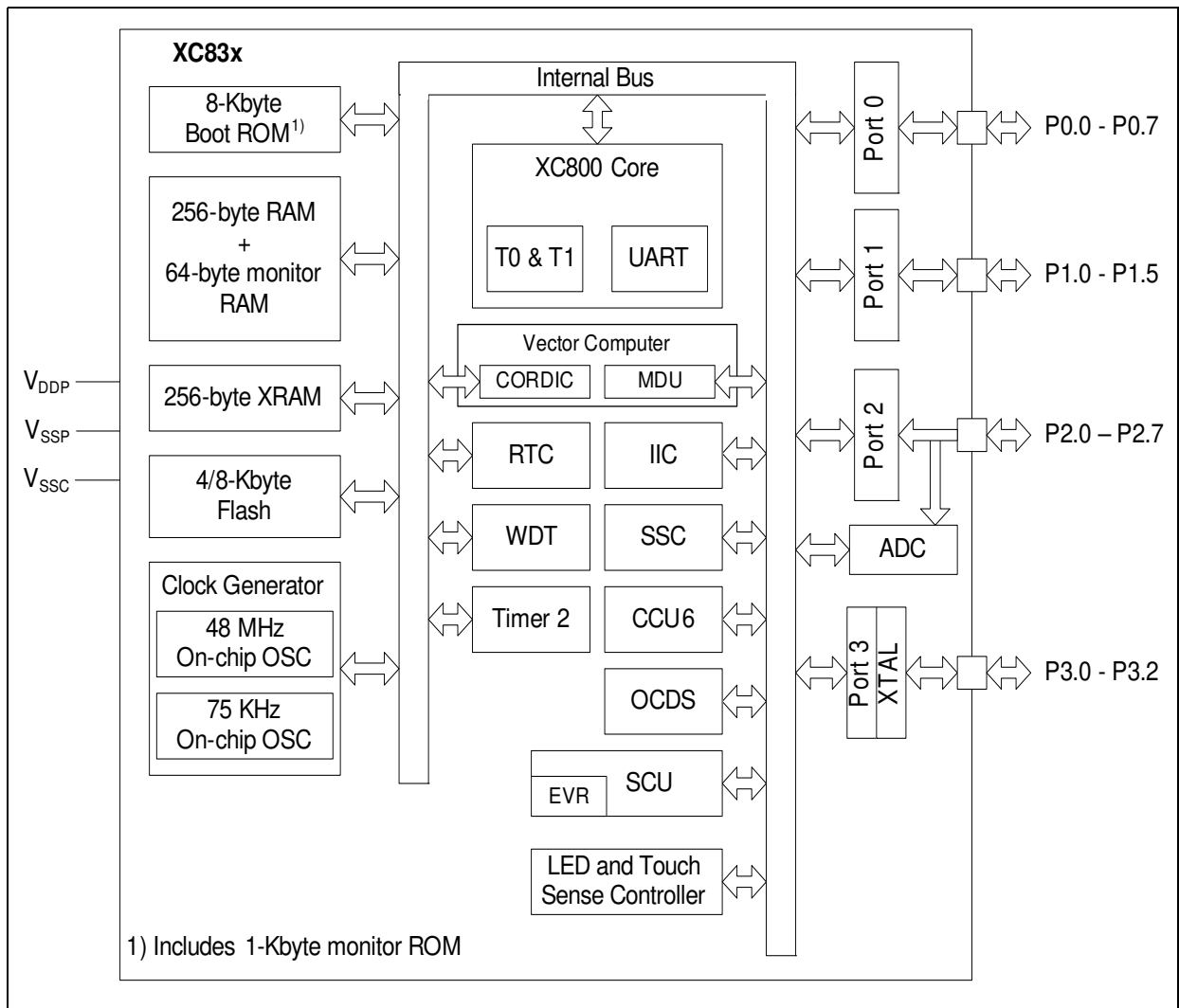

Figure 2 XC835/836 Block Diagram

2.2 Logic Symbol

The logic symbol of the XC835/836 is shown in [Figure 3](#).

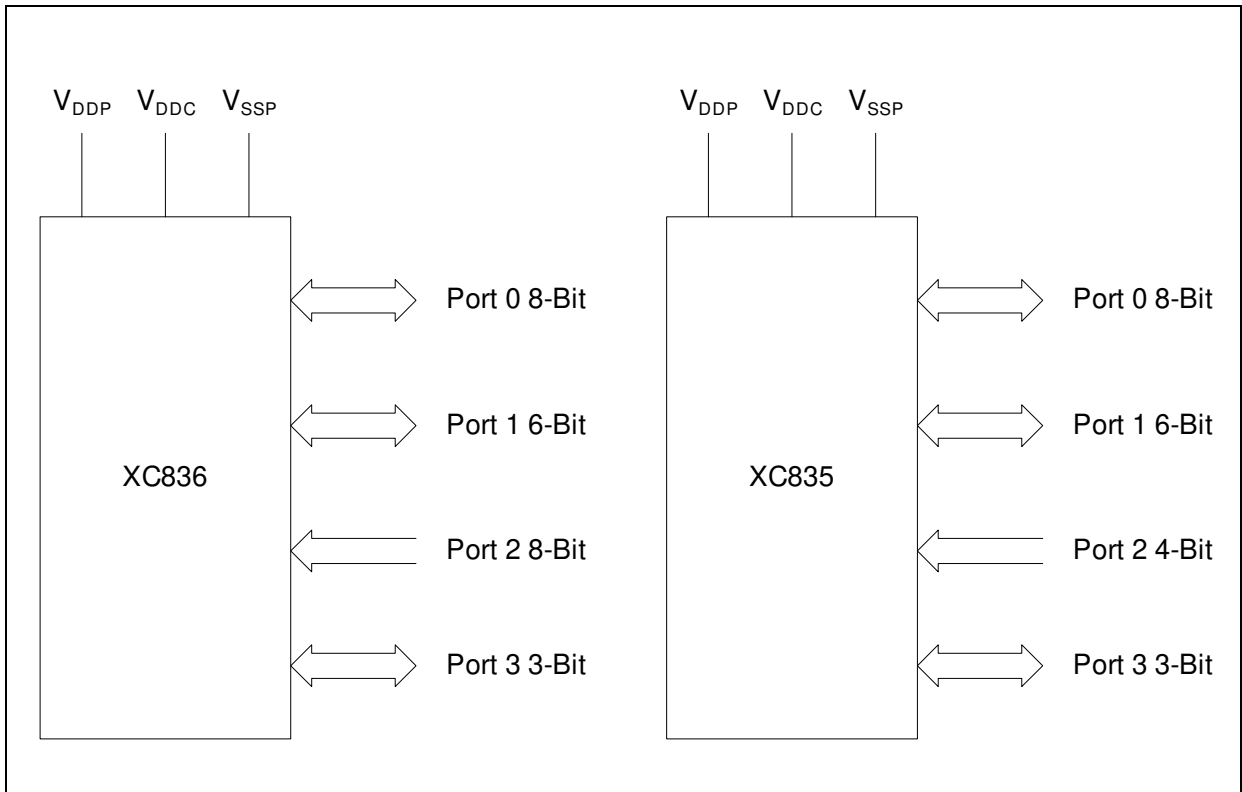

Figure 3 XC835/836 Logic Symbol

2.3 Pin Configuration

The pin configuration of the XC835 in [Figure 4](#).

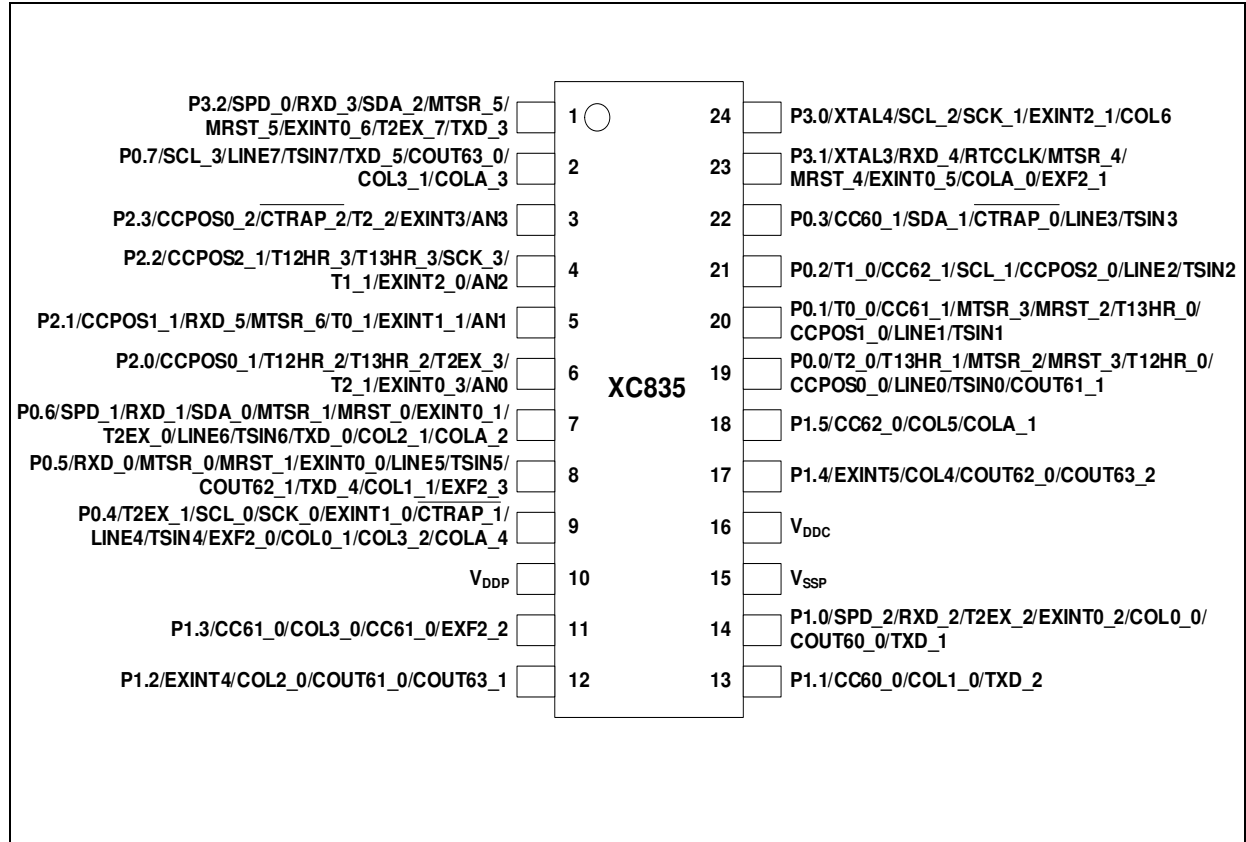

Figure 4 XC835 Pin Configuration, PG-DSO-24 Package (top view)

General Device Information

The pin configuration of the XC836 in [Figure 5](#).

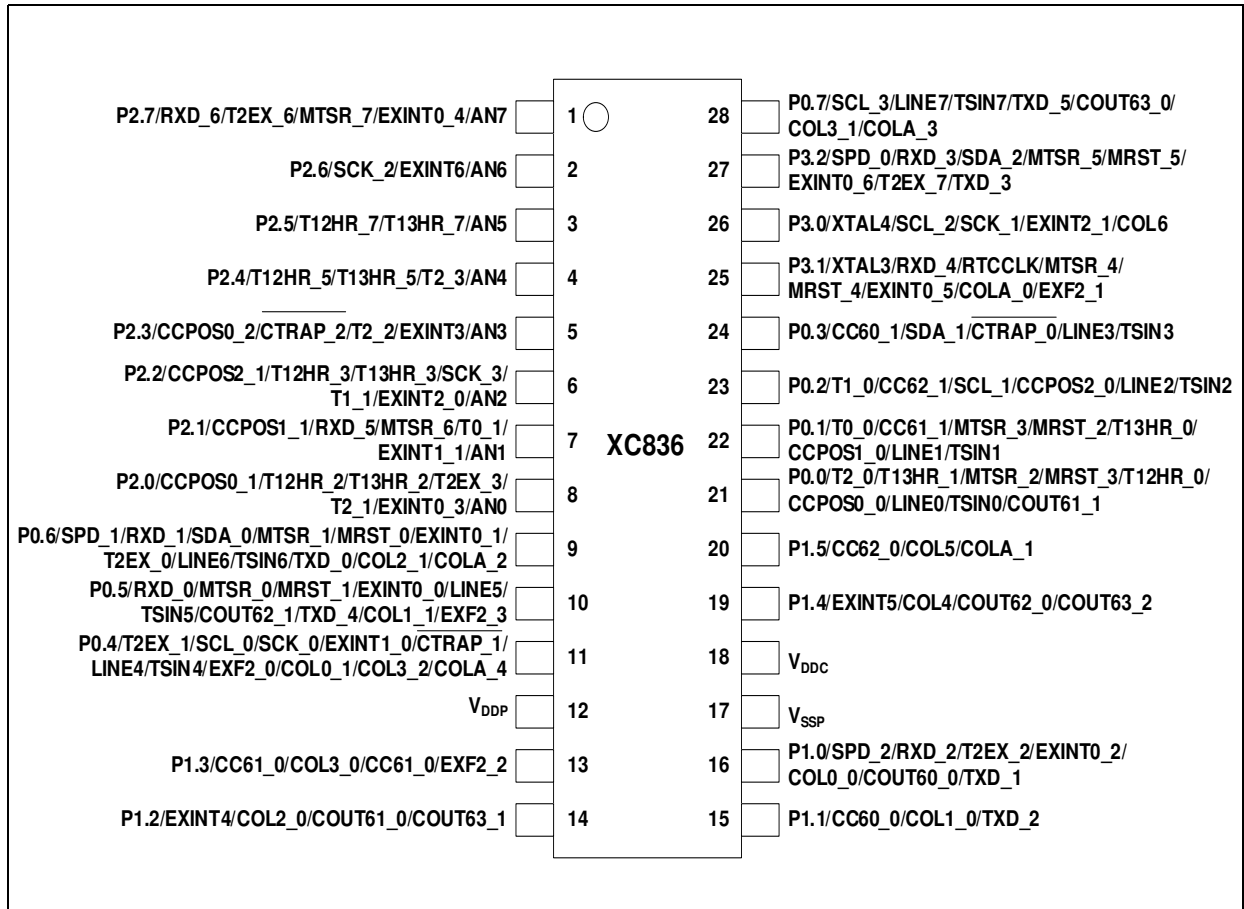

Figure 5 XC836 Pin Configuration, PG-TSSOP-28 Package (top view)

2.4 Pin Definitions and Functions

The functions and default states of the XC835/836 external pins are provided in [Table 3](#).

Table 3 Pin Definitions and Functions for XC835/836

Symbol	Pin Number TSSOP28/ DS024	Type	Reset State	Function
P0		I/O		Port 0 Port 0 is a bidirectional general purpose I/O port. It can be used as alternate functions for LEDTSCU, Timer 0, 1 and 2, SSC, CCU6, IIC, SPD and UART.
P0.0	21/19		Hi-Z	T2_0 Timer 2 Input T13HR_1 CCU6 Timer 13 Hardware Run Input MTSR_2 SSC Master Transmit Output/ Slave Receive Input MRST_3 SSC Master Receive Input T12HR_0 CCU6 Timer 12 Hardware Run Input CCPOS0_0 CCU6 Hall Input 0 TSIN0 Touch-sense Input 0 LINE0 LED Line 0 COUT61_1 Output of Capture/Compare Channel 1

General Device Information
Table 3 Pin Definitions and Functions for XC835/836 (cont'd)

Symbol	Pin Number TSSOP28/ DS024	Type	Reset State	Function
P0.1	22/20		Hi-Z	T0_0 Timer 0 Input CC61_1 Input/Output of Capture/Compare channel 1 MTSR_3 SSC Slave Receive Input MRST_2 SSC Master Receive Input/ Slave Transmit Output T13HR_0 CCU6 Timer 13 Hardware Run Input CCPOS1_0 CCU6 Hall Input 1 TSIN1 Touch-sense Input 1 LINE1 LED Line 1
P0.2	23/21		Hi-Z	T1_0 Timer 1 Input CC62_1 Input/Output of Capture/Compare channel 2 SCL_1 IIC Clock Line CCPOS2_0 CCU6 Hall Input 2 TSIN2 Touch-sense Input 2 LINE2 LED Line 2
P0.3	24/22		Hi-Z	CC60_1 Input/Output of Capture/Compare channel 0 SDA_1 IIC Data Line CTRAP_0 CCU6 Trap Input TSIN3 Touch-sense Input 3 LINE3 LED Line 3

General Device Information
Table 3 Pin Definitions and Functions for XC835/836 (cont'd)

Symbol	Pin Number TSSOP28/ DS024	Type	Reset State	Function
P0.4	11/9		PD	T2EX_1 Timer 2 External Trigger Input SCK_0 SSC Clock Input/Output SCL_0 IIC Clock Line CTRAP_1 CCU6 Trap Input EXINT1_0 External Interrupt Input 1 TSIN4 Touch-sense Input 4 LINE4 LED Line 4 EXF2_0 Timer 2 Overflow Flag COL0_1 LED Column 0 COL3_2 LED Column 3 COLA_4 LED Column A
P0.5	10/8		Hi-Z	RXD_0 UART Receive Input MTSR_0 SSC Master Transmit Output/ Slave Receive Input MRST_1 SSC Master Receive Input EXINT0_0 External Interrupt Input 0 TSIN5 Touch-sense Input 5 LINE5 LED Line 5 COUT62_1 Output of Capture/Compare Channel 2 TXD_4 UART Transmit Output COL1_1 LED Column 1 EXF2_3 Timer 2 Overflow Flag

General Device Information
Table 3 Pin Definitions and Functions for XC835/836 (cont'd)

Symbol	Pin Number TSSOP28/ DS024	Type	Reset State	Function
P0.6	9/7		PU	SPD_1 SPD Input/Output RXD_1 UART Receive Input SDA_0 IIC Data Line MTSR_1 SSC Slave Receive Input MRST_0 SSC Master Receive Input/ Slave Transmit Output EXINT0_1 External Interrupt Input 0 T2EX_0 Timer 2 External Trigger Input TSIN6 Touch-sense Input 6 LINE6 LED Line 6 TXD_0 UART Transmit Output COL2_1 LED Column 2 COLA_2 LED Column A
P0.7	28/2		Hi-Z	SCL_3 IIC Clock Line TSIN7 Touch-sense Input 7 LINE7 LED Line 7 TXD_5 UART Transmit Output/ 2-wire UART BSL Transmit Output COUT63_0 Output of Capture/Compare Channel 3 COL3_1 LED Column 3 COLA_3 LED Column A
P1		I/O		Port 1 Port 1 is a bidirectional general purpose I/O port. It can be used as alternate functions for CCU6, LEDTSCU, SPD, UART and Timer 2

General Device Information
Table 3 Pin Definitions and Functions for XC835/836 (cont'd)

Symbol	Pin Number TSSOP28/ DS024	Type	Reset State	Function
P1.0	16/14		Hi-Z	SPD_2 SPD Input/Output RXD_2 UART Receive Input T2EX_2 Timer 2 External Trigger Input EXINT0_2 External Interrupt Input 0 COL0_0 LED Column 0 COUT60_0 Output of Capture/Compare Channel 0 TXD_1 UART Transmit Output
P1.1	15/13		Hi-Z	CC60_0 Input/Output of Capture/Compare channel 0 COL1_0 LED Column 1 TXD_2 UART Transmit Output
P1.2	14/12		Hi-Z	EXINT4 External Interrupt Input 4 COL2_0 LED Column 2 COUT61_0 Output of Capture/Compare channel 1 COUT63_1 Output of Capture/Compare channel 3
P1.3	13/11		Hi-Z	CC61_0 Input/Output of Capture/Compare channel 1 COL3_0 LED Column 3 EXF2_2 Timer 2 Overflow Flag
P1.4	19/17		Hi-Z	EXINT5 External Interrupt Input 5 COL4 LED Column 4 COUT62_0 Output of Capture/Compare channel 2 COUT63_2 Output of Capture/Compare channel 3

General Device Information
Table 3 Pin Definitions and Functions for XC835/836 (cont'd)

Symbol	Pin Number TSSOP28/ DS024	Type	Reset State	Function
P1.5	20/18		Hi-Z	CC62_0 Input/Output of Capture/Compare channel 2 COL5 LED Column 5 COLA_1 LED Column A
P2		I		Port 2 Port 2 is a general purpose input-only port. It can be used as inputs for A/D Converter and out of range comparator, CCU6, Timer 2, SSC and UART.
P2.0	8/6		Hi-Z	CCPOS0_1 CCU6 Hall Input 0 T12HR_2 CCU6 Timer 12 Hardware Run Input T13HR_2 CCU6 Timer 13 Hardware Run Input T2EX_3 Timer 2 External Trigger Input T2_1 Timer 2 Input EXINT0_3 External Interrupt Input 0 AN0 Analog Input 0 / Out of range comparator channel 0
P2.1	7/5		Hi-Z	CCPOS1_1 CCU6 Hall Input 1 RXD_5 UART Receive Input MTRSR_6 SSC Slave Receive Input T0_1 Timer 0 Input EXINT1_1 External Interrupt Input 1 AN1 Analog Input 1 / Out of range comparator channel 1

General Device Information
Table 3 Pin Definitions and Functions for XC835/836 (cont'd)

Symbol	Pin Number TSSOP28/ DS024	Type	Reset State	Function
P2.2	6/4		Hi-Z	CCPOS2_1 CCU6 Hall Input 2 T12HR_3 CCU6 Timer 12 Hardware Run Input T13HR_3 CCU6 Timer 13 Hardware Run Input SCK_3 SSC Clock Input/Output T1_1 Timer 1 Input EXINT2_0 External Interrupt Input 2 AN2 Analog Input 2 / Out of range comparator channel 2
P2.3	5/3		Hi-Z	CCPOS0_2 CCU6 Hall Input 0 CTRAP_2 CCU6 Trap Input T2_2 Timer 2 Input EXINT3 External Interrupt Input 3 AN3 Analog Input 3 / Out of range comparator channel 3
P2.4	4/-		Hi-Z	T12HR_5 CCU6 Timer 12 Hardware Run Input T13HR_5 CCU6 Timer 13 Hardware Run Input T2_3 Timer 2 Input AN4 Analog Input 4 / Out of range comparator channel 4
P2.5	3/-		Hi-Z	T12HR_7 CCU6 Timer 12 Hardware Run Input T13HR_7 CCU6 Timer 13 Hardware Run Input AN5 Analog Input 5 / Out of range comparator channel 5

General Device Information
Table 3 Pin Definitions and Functions for XC835/836 (cont'd)

Symbol	Pin Number TSSOP28/ DS024	Type	Reset State	Function
P2.6	2/-		Hi-Z	SCK_2 SSC Clock Input/Output EXINT6 External Interrupt Input 6 AN6 Analog Input 6 / Out of range comparator channel 6
P2.7	1/-		Hi-Z	RXD_6 UART Receive Input T2EX_6 Timer 2 External Trigger Input MTSR_7 SSC Slave Receive Input EXINT0_4 External Interrupt Input 0 AN7 Analog Input 7 / Out of range comparator channel 7
P3		I/O		Port 3 Port 3 is a bidirectional general purpose I/O port. It can be used as alternate functions for IIC, LEDTSCU, UART, Timer 2, SSC, SPD and 32.768 kHz crystal pad.
P3.0	26/24		PU	SCL_2 IIC Clock Line SCK_1 SSC Clock Input/Output EXINT2_1 External Interrupt Input 2 COL6 LED Column 6 XTAL4 32.768 kHz External Oscillator Output

General Device Information
Table 3 Pin Definitions and Functions for XC835/836 (cont'd)

Symbol	Pin Number TSSOP28/ DS024	Type	Reset State	Function
P3.1	25/23		PU	RXD_4 UART Receive Input RTCCLK RTC External Clock Input MTSR_4 SSC Master Transmit Output/ Slave Receive Input MRST_4 SSC Master Receive Input EXINT0_5 External Interrupt Input 0 COLA_0 LED Column A XTAL3 32.768 kHz External oscillator Input EXF2_1 Timer 2 Overflow Flag
P3.2	27/1		PU	SPD_0 SPD Input/Output RXD_3 UART Receive Input/ UART BSL Receive Input SDA_2 IIC Data Line MTSR_5 SSC Slave Receive Input MRST_5 SSC Master Receive Input/ Slave Transmit Output EXINT0_6 External Interrupt Input 0 T2EX_7 Timer 2 External Trigger Input TXD_3 UART Transmit Output/ 1-wire UART BSL Transmit Output
V _{DDP}	12/10	–	–	I/O Port Supply (2.5 V - 5.5 V)
V _{DDC}	18/16	–	–	Core Supply Monitor (2.5 V)
V _{SSP} / V _{SSC}	17/15	–	–	I/O Port Ground/ Core Supply Ground

2.5 Memory Organization

The XC835/836 CPU operates in the following five address spaces:

- 8 Kbytes of Boot ROM, Library ROM and User routines
- 256 bytes of internal RAM
- 256 bytes of XRAM
(XRAM can be read/written as program memory or external data memory)
- A 128-byte Special Function Register area
- 4/8 Kbytes of Flash

Figure 6 illustrates the memory address spaces of the 4 Kbyte Flash devices. **Figure 7** illustrates the memory address spaces of the 8 Kbyte Flash devices.

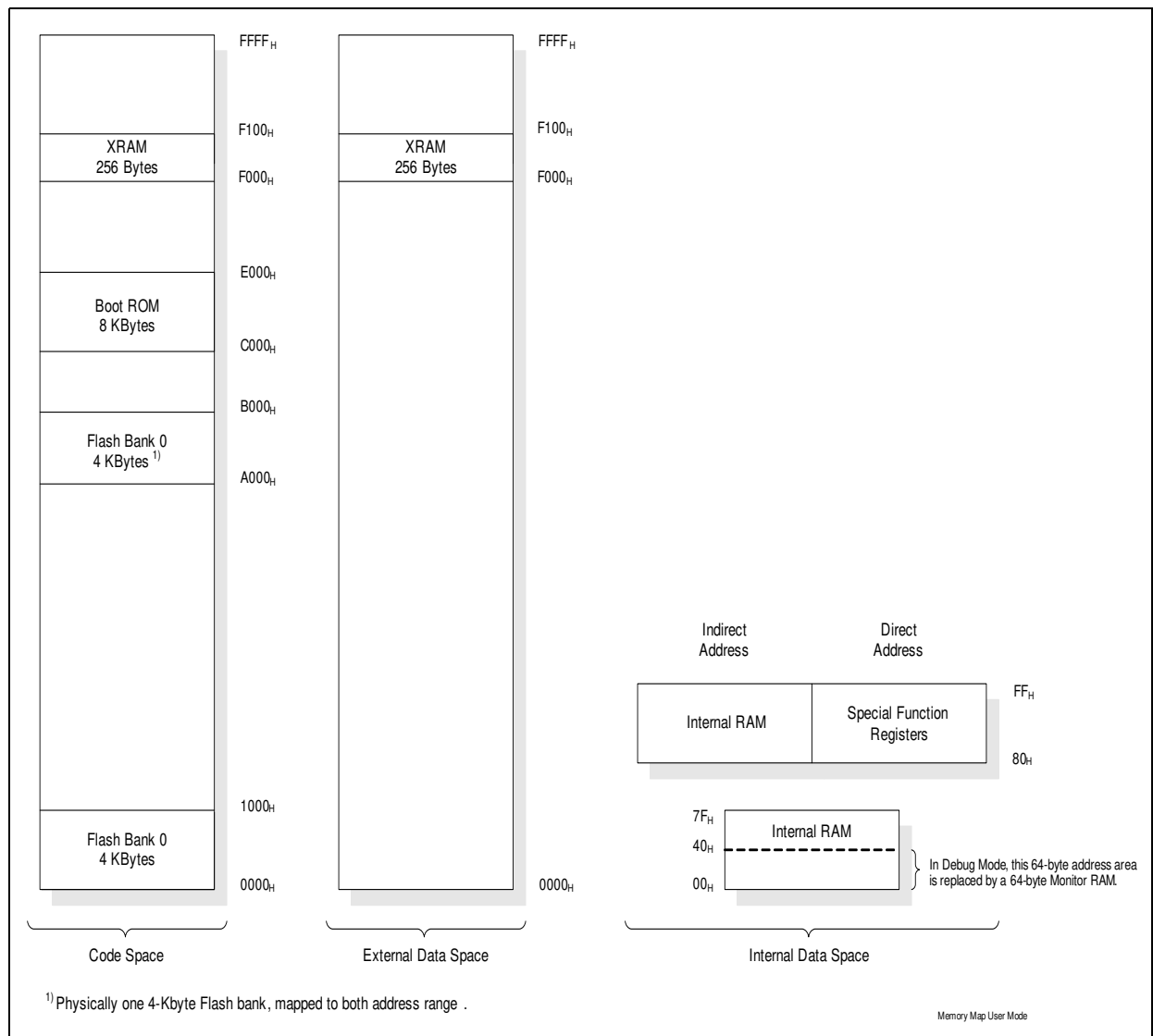

Figure 6 Memory Map of XC835/836 with 4 Kbytes of Flash memory

General Device Information

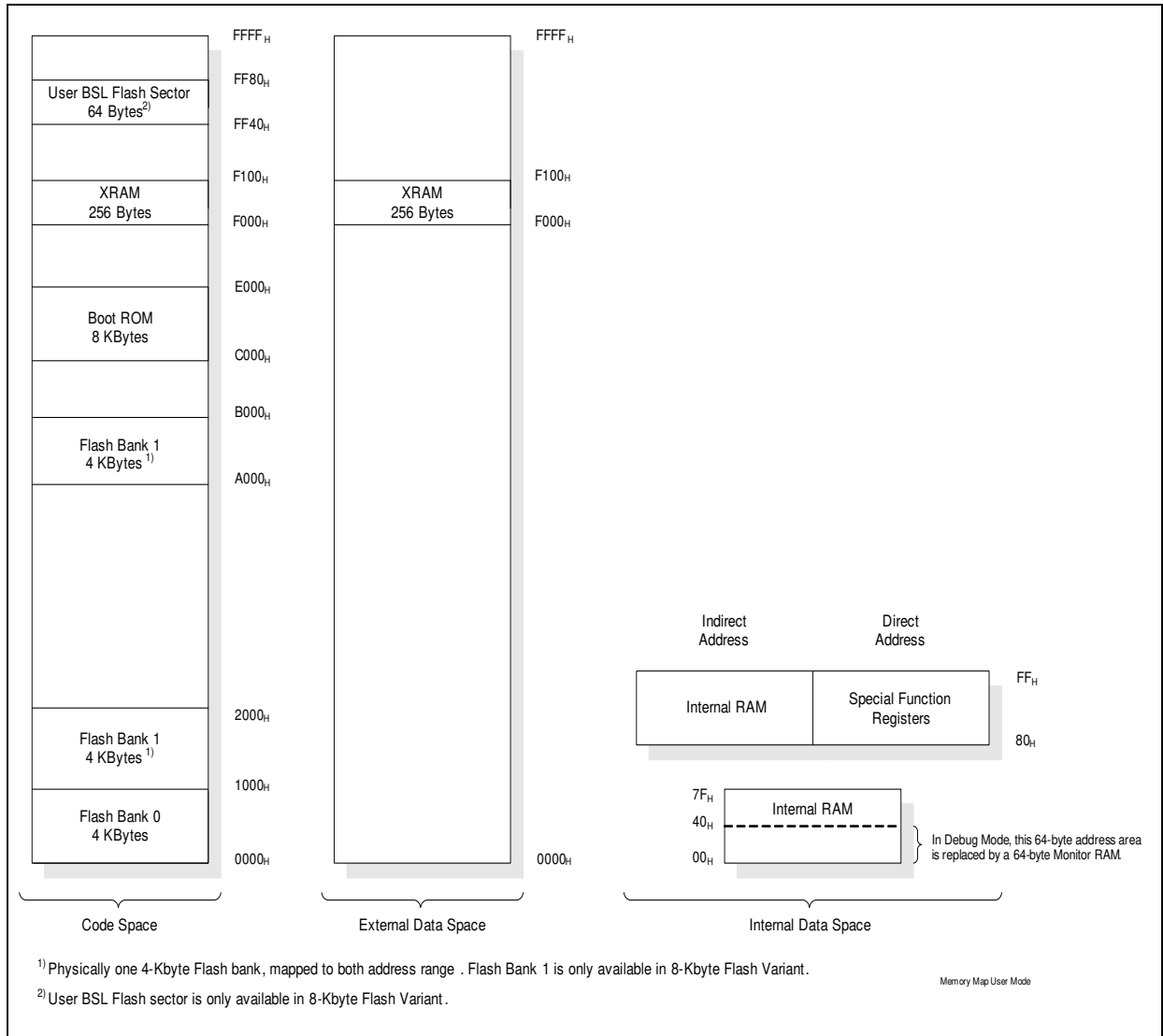

Figure 7 Memory Map of XC835/836 with 8 Kbytes of Flash memory

2.6 JTAG ID

JTAG ID register is a read-only register located inside the JTAG module, and is used to recognize the device(s) connected to the JTAG interface. Its content is shifted out when INSTRUCTION register contains the IDCODE command (opcode 04_H), and the same is also true immediately after reset.

The JTAG ID register contents for the XC835/836 Flash devices are given in [Table 4](#).

Table 4 JTAG ID Summary

Device Type	Device Name	JTAG ID
Flash	XC835*-2FG	101B A083 _H
	XC836*-2FR	
	XC836*-1FR	101B B083 _H

Note: The asterisk () above denotes all possible device configurations.*

2.7 Chip Identification Number

The XC835/836 identity (ID) register is located at Page 1 of address B3_H. The value of ID register is 59_H. However, for easy identification of product variants, the Chip Identification Number, which is a unique number assigned to each product variant, is available. The differentiation is based on the product and variant type information.

Two methods are provided to read a device's Chip Identification number:

- In-application subroutine, GET_CHIP_INFO
- Boot-loader (BSL) mode A

Table 5 lists the Chip Identification numbers of XC835/836 device variants.

Table 5 Chip Identification Number

Product Variant	Chip Identification Number
XC835MT-2FG	59100001 _H
XC836-2FR	59100060 _H
XC836T-2FR	59100040 _H
XC836M-2FR	59100020 _H
XC836M-1FR	59100120 _H
XC836MT-2FR	59100000 _H
XC836MT-1FR	59100100 _H

3 Electrical Parameters

Chapter 3 provides the characteristics of the electrical parameters which are implementation-specific for the XC835/836.

3.1 General Parameters

The general parameters are described here to aid the users in interpreting the parameters mainly in **Section 3.2** and **Section 3.3**.

3.1.1 Parameter Interpretation

The parameters listed in this section represent partly the characteristics of the XC835/836 and partly its requirements on the system. To aid interpreting the parameters easily when evaluating them for a design, they are indicated by the abbreviations in the "Symbol" column:

- **CC**
 - These parameters indicate **C**ontroller **C**haracteristics, which are distinctive features of the XC835/836 and must be regarded for a system design.
- **SR**
 - These parameters indicate **S**ystem **R**equirements, which must be provided by the microcontroller system in which the XC835/836 is designed in.

3.1.2 Absolute Maximum Rating

Maximum ratings are the extreme limits to which the XC835/836 can be subjected to without permanent damage.

Table 6 Absolute Maximum Rating Parameters

Parameter	Symbol	Limit Values		Unit	Notes
		Min.	Max.		
Ambient temperature	T_A	-40	125	°C	under bias
Storage temperature	T_{ST}	-65	150	°C	–
Junction temperature	T_J	-40	150	°C	under bias
Voltage on power supply pin with respect to V_{SS}	V_{DDP}	-0.5	6	V	
Maximum current per pin for P1[3:0]	I_M	-115	115	mA	
Input current on any pin during overload condition	I_{IN}	-10	10	mA	
Absolute sum of all input currents during overload condition	$\Sigma I_{IN} $	–	50	mA	

Note: Stresses above those listed under “Absolute Maximum Ratings” may cause permanent damage to the device. This is a stress rating only and functional operation of the device at these or any other conditions above those indicated in the operational sections of this specification is not implied. Exposure to absolute maximum rating conditions for extended periods may affect device reliability. During absolute maximum rating overload conditions ($V_{IN} > V_{DDP}$ or $V_{IN} < V_{SS}$) the voltage on V_{DDP} pin with respect to ground (V_{SS}) must not exceed the values defined by the absolute maximum ratings.

3.1.3 Operating Condition

The following operating conditions must not be exceeded in order to ensure correct operation of the XC835/836. All parameters mentioned in the following tables refer to these operating conditions, unless otherwise noted.

Table 7 Operating Condition Parameters

Parameter	Symbol	Limit Values		Unit	Notes/ Conditions
		Min.	Max.		
Digital power supply voltage	V_{DDP}	3.0	5.5	V	
		2.5	3.0	V	¹⁾
Digital core supply voltage ²⁾	V_{DDC}	2.3	2.7	V	
CPU Clock Frequency	f_{CCLK}	22.5	25.6	MHz	typ. 24 MHz
		7.5	8.5	MHz	typ. 8 MHz
Ambient temperature	T_A	-40	85	°C	SAF-XC835/836...
		-40	125	°C	SAK-XC836...

1) In this voltage range, limited operations are available in active mode. Operations in power save modes are fully supported.

2) V_{DDC} is supplied by the on-chip EVR. The limits are verified by design and production testing.

3.2 DC Parameters

The electrical characteristics of the DC Parameters are detailed in this section.

3.2.1 Input/Output Characteristics

Table 8 provides the characteristics of the input/output pins of the XC835/836.

Table 8 Input/Output Characteristics (Operating Conditions apply)

Parameter	Symbol	Limit Values	Unit	Test Conditions	
					Min.
Output low voltage on port pins (all except P1)	V_{OLP} CC	–	1.0	V	$I_{OL} = 25 \text{ mA (5 V)}$ $I_{OL} = 13 \text{ mA (3.3 V)}$
		–	0.4	V	$I_{OL} = 10 \text{ mA (5 V)}$ $I_{OL} = 5 \text{ mA (3.3 V)}$
Output low voltage on P1[3:0]	V_{OLP1} CC	–	1.0	V	$I_{OL} = 50 \text{ mA (5 V)}$ $I_{OL} = 25 \text{ mA (3.3 V)}$
		–	0.32	V	$I_{OL} = 20 \text{ mA (5 V)}$
		–	0.4	V	$I_{OL} = 10 \text{ mA (3.3 V)}$
Output low voltage on P1[5:4]	V_{OLP2} CC	–	1.0	V	$I_{OL} = 50 \text{ mA (5 V)}$ $I_{OL} = 25 \text{ mA (3.3 V)}$
		–	0.4	V	$I_{OL} = 20 \text{ mA (5 V)}$ $I_{OL} = 10 \text{ mA (3.3 V)}$
Output high voltage on port pins (all except P1)	V_{OHP} CC	$V_{DDP} - 1.0$	–	V	$I_{OH} = -15 \text{ mA (5 V)}$ $I_{OH} = -8 \text{ mA (3.3 V)}$
		$V_{DDP} - 0.4$	–	V	$I_{OH} = -5 \text{ mA (5 V)}$ $I_{OH} = -2.5 \text{ mA (3.3 V)}$
Output high voltage on P1[3:0]	V_{OHP1} CC	$V_{DDP} - 0.32$	–	V	$I_{OH} = -20 \text{ mA (5 V)}$
		$V_{DDP} - 1.0$	–	V	$I_{OH} = -25 \text{ mA (3.3 V)}$
		$V_{DDP} - 0.4$	–	V	$I_{OH} = -10 \text{ mA (3.3 V)}$
Output high voltage on P1[5:4]	V_{OHP2} CC	$V_{DDP} - 1.0$	–	V	$I_{OH} = -30 \text{ mA (5 V)}$ $I_{OH} = -16 \text{ mA (3.3 V)}$
		$V_{DDP} - 0.4$	–	V	$I_{OH} = -10 \text{ mA (5 V)}$ $I_{OH} = -5 \text{ mA (3.3 V)}$

Electrical Parameters
Table 8 Input/Output Characteristics (Operating Conditions apply) (cont'd)

Parameter	Symbol		Limit Values		Unit	Test Conditions
			Min.	Max.		
Input low voltage on port pins	V_{ILP}	SR	–	$0.3 \times V_{DDP}$	V	CMOS Mode (5 & 3.3 V)
Input high voltage on port pins	V_{IHP}	SR	$0.7 \times V_{DDP}$	–	V	CMOS Mode (5 V & 3.3 V)
Input Hysteresis ¹⁾	HYS	CC	$0.08 \times V_{DDP}$	–	V	CMOS Mode (5 V)
			$0.03 \times V_{DDP}$	–	V	CMOS Mode (3.3 V)
			$0.01 \times V_{DDP}$	–	V	CMOS Mode (2.5 V)
Pull-up current	I_{PUP}	SR	–	-20	μA	$V_{IH,min}$ (5 V)
			-150	–	μA	$V_{IL,max}$ (5 V)
			–	-5	μA	$V_{IH,min}$ (3.3 V)
			-100	–	μA	$V_{IL,max}$ (3.3 V)
Pull-down current	I_{PDP}	SR	–	20	μA	$V_{IL,max}$ (5 V)
			150	–	μA	$V_{IH,min}$ (5 V)
			–	5	μA	$V_{IL,max}$ (3.3 V)
			100	–	μA	$V_{IH,min}$ (3.3 V)
Input leakage current on port pins ²⁾ (all except P1)	I_{OZP}	CC	-1	1	μA	$0 < V_{IN} < V_{DDP}$, $T_A \leq 125 \text{ }^\circ C$
Input leakage current on P1[3:0] ²⁾	I_{OZP1}	CC	-3	3	μA	$0 < V_{IN} < V_{DDP}$, $T_A \leq 125 \text{ }^\circ C$
Input leakage current on P1[5:4] ²⁾	I_{OZP2}	CC	-2	2	μA	$0 < V_{IN} < V_{DDP}$, $T_A \leq 125 \text{ }^\circ C$
Overcurrent threshold per pin for P1[3:0] ³⁾	$ I_{OCP1} $	SR	60	115	mA	$V_{DDP} = 5 \text{ V}$
Overload current on any pin	I_{OVP}	SR	-5	5	mA	⁴⁾
Absolute sum of overload currents	$\Sigma I_{OV} $	SR	–	25	mA	⁴⁾

Electrical Parameters
Table 8 Input/Output Characteristics (Operating Conditions apply) (cont'd)

Parameter	Symbol		Limit Values		Unit	Test Conditions
			Min.	Max.		
Voltage on any pin during V_{DDP} power off	V_{PO}	SR	–	0.3	V	5)
Maximum current per pin (excluding P1, V_{DDP} and V_{SS})	I_{MP}	SR	-15	25	mA	–
Maximum current per pin for P1[3:0]	I_{MP1A}	SR	-50	50	mA	–
Maximum current per pin for P1[5:4]	I_{MP1B}	SR	-30	50	mA	–
Maximum current into V_{DDP}	I_{MVDDP}	SR	–	130	mA	4)
Maximum current out of V_{SS}	I_{MVSS}	SR	–	130	mA	4)

- 1) Not subjected to production test, verified by design/characterization. Hysteresis is implemented to avoid meta stable states and switching due to internal ground bounce. It cannot be guaranteed that it suppresses switching due to external system noise.
- 2) An additional error current (I_{INJ}) will flow if an overload current flows through an adjacent pin.
- 3) Over current detection is available for 5V application only.
- 4) Not subjected to production test, verified by design/characterization.
- 5) Not subjected to production test, verified by design/characterization. However, for applications with strict low power-down current requirements, it is mandatory that no active voltage source is supplied at any GPIO pin when V_{DDP} is powered off.

3.2.2 Supply Threshold Characteristics

Table 9 provides the characteristics of the supply threshold in the XC835/836.

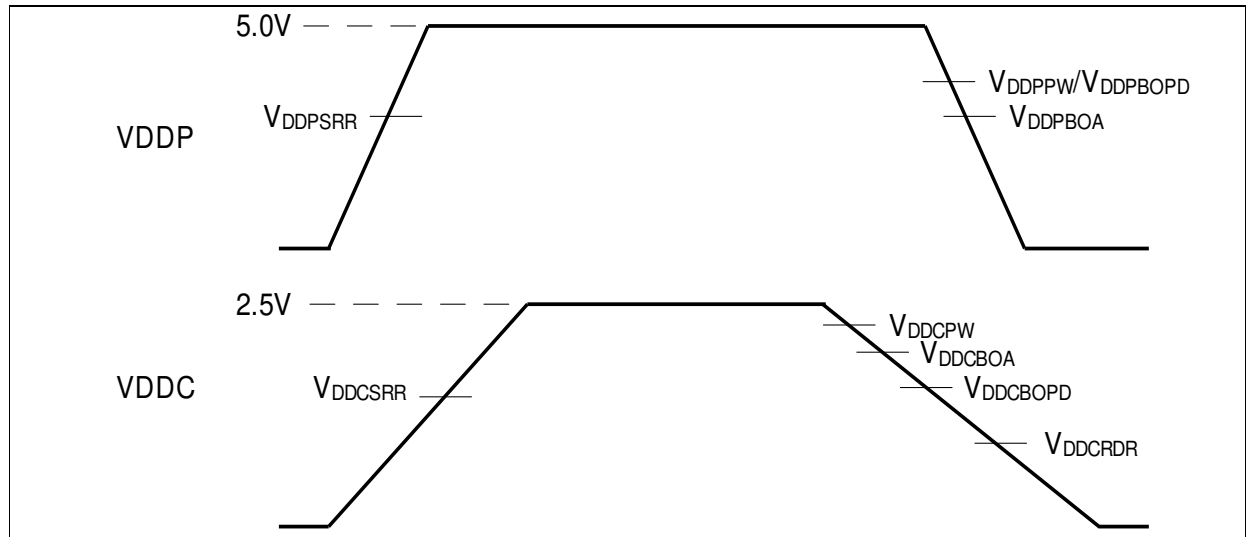

Figure 8 Supply Threshold Parameters

Table 9 Supply Threshold Parameters (Operating Conditions apply)

Parameters	Symbol		Limit Values			Unit
			Min.	Typ.	Max.	
V_{DDP} prewarning voltage ¹⁾²⁾	V_{DDPPW}	CC	3.0	3.6	4.5	V
V_{DDP} brownout voltage in active mode ²⁾³⁾	V_{DDPBOA}	CC	2.65	2.75	2.87	V
V_{DDP} brownout voltage in all power down mode ²⁾³⁾	$V_{DDPBOPD}$		3.0	3.6	4.5	V
V_{DDP} system reset release voltage ²⁾⁴⁾	V_{DDPSRR}	CC	2.7	2.8	2.92	V
V_{DDC} prewarning voltage ²⁾⁵⁾	V_{DDCPW}	CC	2.3	2.4	2.48	V
V_{DDC} brownout voltage in active mode ²⁾	V_{DDCBOA}	CC	2.25	2.3	2.42	V
V_{DDC} brownout voltage in power down mode ²⁾	$V_{DDCBOPD}$	CC	1.35	1.5	1.95	V
V_{DDC} system reset release voltage ²⁾⁴⁾	V_{DDCSRR}	CC	2.28	2.3	2.47	V
RAM data retention voltage	V_{DDCRDR}	CC	1.1	–	–	V

1) Detection is enabled via SDCON register in active mode. It is automatically disabled in power down mode. Detection should be disabled for V_{DDP} less than maximum of V_{DDPPW} .

2) This parameter has a hysteresis of 50 mV.

3) Detection is enabled via SDCON register. Detection must be disabled for application with V_{DDP} less than the specified values.

4) V_{DDPSRR} and V_{DDCSRR} must be met before the system reset is released.

5) Detection is enabled via SDCON register in active mode. It is automatically disabled in power down mode.

3.2.3 ADC Characteristics

The values in **Table 10** are given for an analog power supply of 5.0 V. The ADC can be used with an analog power supply down to 3 V. But in this case, analog parameters may show a reduced performance. In the reduced voltage mode ($2.5\text{ V} < V_{DDP} < 3\text{ V}$), the ADC is not recommended to be used.

Table 10 ADC Characteristics (Operating Conditions apply; $V_{DDP} = 5\text{ V}$; $f_{ADCI} \leq 12\text{ MHz}$)

Parameter	Symbol		Limit Values			Unit	Test Conditions / Remarks
			Min.	Typ.	Max.		
Analog reference voltage	V_{AREF}		–	V_{DDP}	–	V	Connect internally to V_{DDP}
Analog reference ground	V_{AGND}		–	V_{SSP}	–	V	Connect internally to V_{SSP}
Alternate analog reference ground	$V_{AGNDALT}$	SR	$V_{SSP} - 0.1$	–	$2.5^{1)}$	V	Connect to AN0 in differential mode, See Figure 9 .
Internal voltage reference	V_{INTREF}	SR	1.19	1.23	1.28	V	⁴⁾
Analog input voltage range	V_{AIN}	SR	V_{AGND}	–	V_{AREF}	V	–
ADC clock	f_{ADCI}		8	–	16	MHz	internal analog clock
Sample time	t_S	CC	$(2 + INPCR0.STC) \times t_{ADCI}$			μs	–
Conversion time	t_C	CC	See Section 3.2.3.1			μs	–
Set-up time between conversions using internal voltage reference	t_{SETUP}	SR	–	35	–	μs	²⁾

Electrical Parameters
Table 10 ADC Characteristics (Operating Conditions apply; $V_{DDP} = 5\text{ V}$; $f_{ADCI} \leq 12\text{ MHz}$) (cont'd)

Parameter	Symbol		Limit Values			Unit	Test Conditions / Remarks
			Min.	Typ.	Max.		
Total unadjusted error	$TUE^{3)}$	CC	–	–	± 1	LSB8	8-bit conversion with internal reference ⁴⁾
			–	–	+4/-2	LSB10	10-bit conversion with internal reference ⁴⁾⁵⁾
			–	–	+14/-2	LSB12	12-bit conversion using the Low Pass Filter ⁴⁾
Differential Nonlinearity	EA_{DNL}	CC	–	–	+1.5/ -1	LSB	10-bit conversion ⁴⁾
Integral Nonlinearity	EA_{INL}	CC	–	–	± 1.5	LSB	10-bit conversion ⁴⁾
Offset	EA_{OFF}	CC	–	+4	–	LSB	10-bit conversion ⁴⁾
Gain	EA_{GAIN}	CC	–	-4	–	LSB	10-bit conversion ⁴⁾
Switched capacitance at an analog input	C_{AINSW}	CC	–	2	3	pF	⁴⁾⁶⁾
Total capacitance at an analog input	C_{AINT}	CC	–	–	12	pF	⁴⁾⁶⁾
Input resistance of an analog input	R_{AIN}	CC	–	1.5	2	k Ω	⁴⁾

1) 1.2 V at $V_{DDP} = 3.0\text{ V}$.

2) Not subject to production test, verified at CPU clock ($f_{SCLK, CCLK}$) = 8 MHz, $T_A = +25\text{ }^\circ\text{C}$ and $V_{DDP} = 5\text{ V}$.

3) TUE is tested at $V_{AREF} = V_{DDP} = 5.0\text{ V}$ and CPU clock ($f_{SCLK, CCLK}$) = 8 MHz.

4) Not subject to production test, verified by design/characterization.

5) If a reduced positive reference voltage is used, TUE will increase. If the positive reference is reduced by a factor of K, the TUE will increased by 1/K. Example:K = 0.8, 1/K = 1.25; 1.25 X TUE = 2.5 LSB10.

6) The sampling capacity of the conversion C-Network is pre-charged to $V_{AREF}/2$ before connecting the input to the C-Network. Because of the parasitic elements, the voltage measured at ANx is lower than $V_{AREF}/2$.

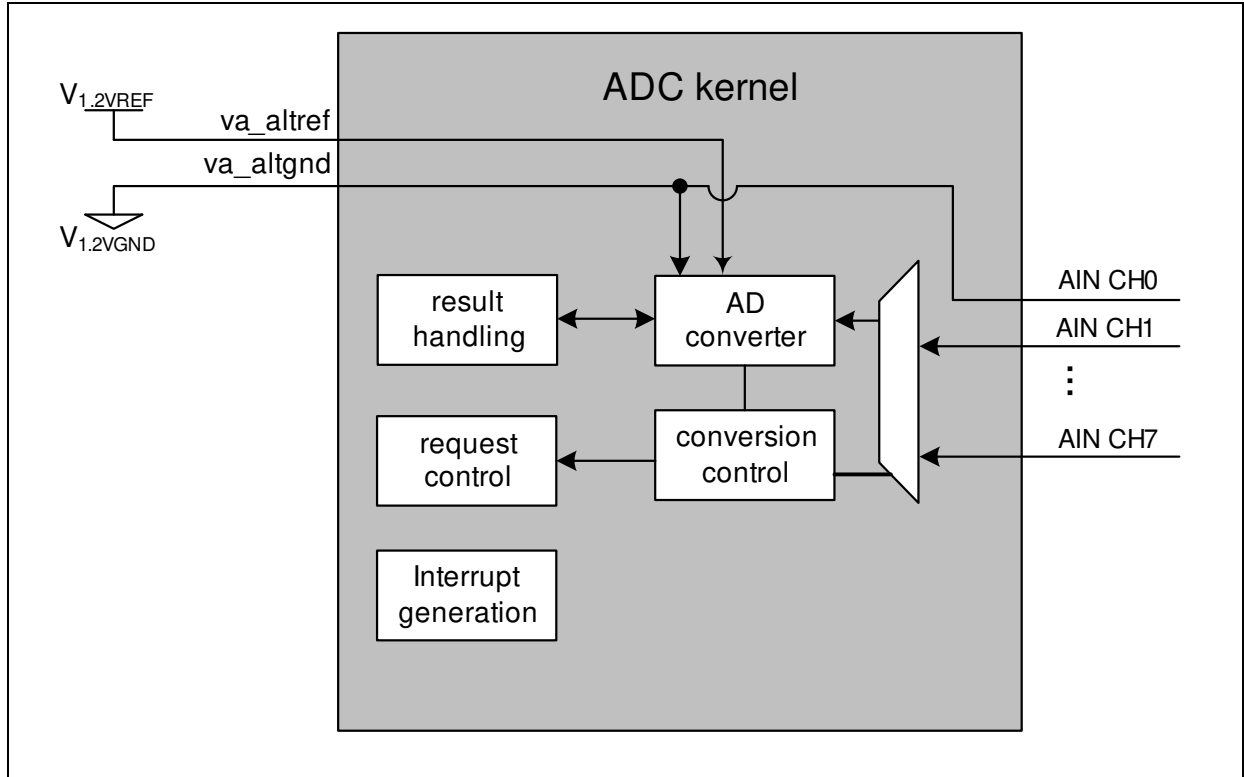

Figure 9 Differential like measurement with internal 1.2V voltage reference, and CH0 gnd.

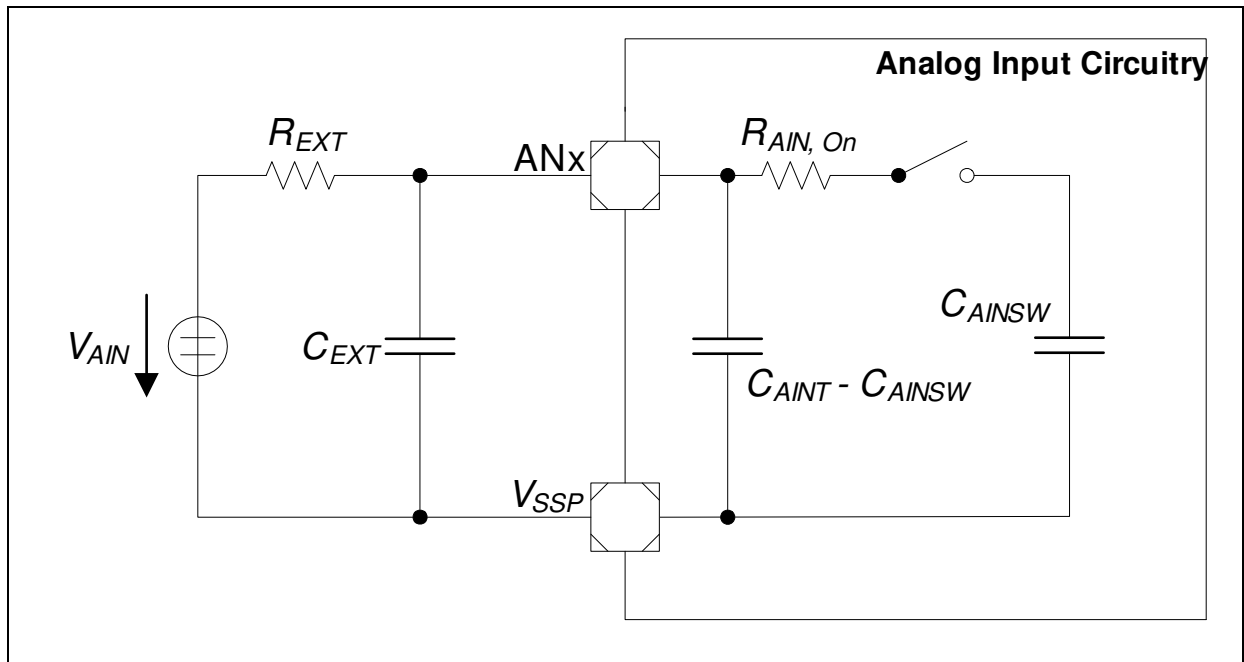

Figure 10 ADC Input Circuits

3.2.3.1 ADC Conversion Timing

Conversion time, $t_C = t_{ADC} \times (1 + r \times (3 + n + STC))$, where

- $r = CTC + 3$,
- $CTC =$ Conversion Time Control (GLOBCTR.CTC),
- $STC =$ Sample Time Control (INPCR0.STC),
- $n = 8$ or 10 (for 8-bit and 10-bit conversion respectively),
- $t_{ADC} = 1 / f_{ADC}$

3.2.3.2 Out of Range Comparator Characteristics

Table 11 below shows the Out of Range Comparator characteristics.

Table 11 Out of Range Comparator Characteristics (Operating Conditions apply)

Parameter	Symbol		Limit Values			Unit	Remarks
			Min.	Typ.	Max.		
DC Switching Level	$V_{SenseDC}$	SR	60	125	270	mV	Above V_{DDP}
DC Hysteresis	$V_{SenseHys}$	CC	30	–	–	mV	¹⁾
Pulse Width	$t_{SensePW}$	SR	300	–	–	ns	$ANx > V_{DDP}$ ¹⁾
Switching Delay	$t_{SenseSD}$	CC	–	–	400	ns	$ANx \geq V_{DDP} + 350$ mV ¹⁾
Pulse Switching Level	$t_{SensePSL}$	SR	–	250	–	mV	@ 300 nsec ¹⁾
		SR	–	60	–	mV	@ 800 usec ¹⁾

1) Not subject to production test, verified by design/characterization.

3.2.4 Flash Memory Parameters

The XC835/836 is delivered with all Flash sectors erased (read all zeros).

The data retention time of the XC835/836's Flash memory (i.e. the time after which stored data can still be retrieved) depends on the number of times the Flash memory has been erased and programmed.

Note: Flash memory parameters are not subject to production test but verified by design and/or characterization.

Table 12 Flash Timing Parameters (Operating Conditions apply)

Parameter	Symbol	CC	Limit Values			Unit	Remarks
			Min.	Typ.	Max.		
Read access time (per byte)	t_{ACC}	CC	–	125	–	ns	
Programming time (per wordline)	t_{PR}	CC	–	2.2	–	ms	
Erase time (one or more sectors)	t_{ER}	CC	–	120	–	ms	
Flash wait states	$N_{WSFLASH}$	CC	0				CPU clock = 8 MHz
			1				CPU clock = 24 MHz

Table 13 Flash Data Retention and Endurance (Operating Conditions apply)

Retention	Endurance ¹⁾	Size	Remarks
20 years	1,000 cycles	up to 8 Kbytes	
5 years	10,000 cycles	1 Kbyte	
2 years	70,000 cycles	512 bytes	
2 years	100,000 cycles	128 bytes	

1) One cycle refers to the programming of all wordlines in a sector and erasing of sector. The Flash endurance data specified in **Table 13** is valid only if the following conditions are fulfilled:

- the maximum number of erase cycles per Flash sector must not exceed 100,000 cycles.
- the maximum number of erase cycles per Flash bank must not exceed 300,000 cycles.
- the maximum number of program cycles per Flash bank must not exceed 2,500,000 cycles.

Electrical Parameters

Table 14 Emulated Flash Data Retention and Endurance based on EEPROM Emulation ROM Library (Operating Conditions apply)

Retention	Endurance ¹⁾	Emulation Size	Remarks
2 years	1,600,000 cycles	31 bytes	
2 years	1,400,000 cycles	62 bytes	
2 years	1,200,000 cycles	93 bytes	
2 years	1,000,000 cycles	124 bytes	

1) These values show the maximum endurance. Maximum endurance is the maximum possible unique data write if each data update is only 31 bytes. Minimum endurance cycle is the maximum possible unique data write if each data update is the same as the emulation size. The minimum endurance cycle can be calculated using the formulae [(max. endurance)*(31)/(emulation size)].

3.2.5 Power Supply Current

Table 15 provides the characteristics of the power supply current in the XC835/836.

Table 15 Power Consumption Parameters^{1) 2)}(Operating Conditions apply)

Parameter	Symbol	Limit Values		Unit	Test Condition
		Typ.	Max.		
Active Mode	I_{DDPA}	23	28	mA	5 V / 3.3 V ³⁾
		16	20	mA	5 V / 3.3 V ⁴⁾
		–	5	mA	2.5 V ⁵⁾
Idle Mode	I_{DDP1}	18	25	mA	5 V / 3.3 V ⁶⁾
		–	5	mA	2.5 V ⁵⁾
Power Down Mode 1	I_{PDP1}	3	5	μA	$T_A = 25^\circ\text{C}$ ⁷⁾
		–	28	μA	$T_A = 85^\circ\text{C}$ ⁷⁾⁸⁾⁹⁾
Power Down Mode 2	I_{PDP2}	6	8	μA	$T_A = 25^\circ\text{C}$ ⁷⁾⁸⁾
		–	31	μA	$T_A = 85^\circ\text{C}$ ⁷⁾⁸⁾⁹⁾
Power Down Mode 3	I_{PDP3}	5	7	μA	$T_A = 25^\circ\text{C}$ ⁷⁾⁸⁾
		–	30	μA	$T_A = 85^\circ\text{C}$ ⁷⁾⁸⁾⁹⁾
Power Down Mode 4	I_{PDP4}	5	7	μA	$T_A = 25^\circ\text{C}$ ⁷⁾
		–	30	μA	$T_A = 85^\circ\text{C}$ ⁷⁾⁸⁾⁹⁾

- 1) The typical I_{DDP} values are measured at $T_A = +25^\circ\text{C}$ and $V_{DDP} = 5\text{ V}$ and 3.3 V .
- 2) The maximum I_{DDP} values are measured under worst case conditions ($T_A = +125^\circ\text{C}$ and $V_{DDC} = 5\text{ V}$) unless stated otherwise.
- 3) I_{DDP} (active mode) is measured with: CPU clock and input clock to all peripherals running at 24 MHz (CLKMODE=0).
- 4) I_{DDP} (active mode) is measured with: CPU clock and input clock to all peripherals running at 8 MHz (CLKMODE=1).
- 5) This value is based on the maximum load capacity of EVR during $V_{DDP} = 2.5\text{ V}$. Not subject to production test, verified by design/characterisation.
- 6) I_{DDP1} (idle mode) is measured with: CPU clock disabled, watchdog timer disabled, input clock to all peripherals enabled and running at 24 MHz (CLKMODE=0).
- 7) I_{PDP1} , I_{PDP2} , I_{PDP3} and I_{PDP4} is measured at 5 V and 3.3 V with: wake-up port is programmed to be input with either internal pull devices enabled or driven externally to ensure no floating inputs.
- 8) Not subject to production test, verified by design/characterisation.
- 9) I_{PDP1} , I_{PDP2} , I_{PDP3} and I_{PDP4} has a maximum values of 120 μA at $T_A = +125^\circ\text{C}$.

Electrical Parameters

Table 16 shows the maximum active current within the device in the reduced voltage condition of $2.5\text{ V} < V_{DDP} < 3.0\text{ V}$. The active current consumption needs to be below the specified values as according to the V_{DDP} voltage. If the conditions are not met, a brownout reset may be triggered.

Table 16 Active Current Consumption in Reduced Voltage Condition

V_{DDP}	2.5 V	2.6 V	2.7 V	2.8 V
Maximum active current	7 mA	13 mA	20 mA	25 mA

Table 17 provides the active current consumption of some modules operating at 8 MHz active mode, 3 V power supply at 25°C . The typical values shown are used as a reference guide for device operating in reduced voltage conditions.

Table 17 Typical Active Current Consumption^{1) 2)}

Active Current Consumption	Symbol	Limit Values	Unit	Test Condition
		Typ.		
Baseload current ³⁾	I_{CPUDDC}	6900	μA	Modules including Core, memories, UART, T0, T1 and EVR. Disable ADC analog (GLOBCTR.ANON = 0).
ADC ⁴⁾	I_{ADCDDC}	3760	μA	Set PMCON1.ADC_DIS to 0 and GLOBECTR.ANON to 1
SSC ⁵⁾	I_{SSCDDC}	460	μA	Set PMCON1.SSC_DIS to 0
CCU6 ⁶⁾	$I_{CCU6DDC}$	3320	μA	Set PMCON1.CCU_DIS to 0
Timer 2 ⁷⁾	I_{T2DDC}	200	μA	Set PMCON1.T2_DIS to 0
MDU ⁸⁾	I_{MDUDDC}	1260	μA	Set PMCON1.MDU_DIS to 0
CORDIC ⁹⁾	$I_{CORDICDDC}$	1880	μA	Set PMCON1.CDC_DIS to 0
LEDTSCU ¹⁰⁾	I_{LEDDDC}	850	μA	Set PMCON1.LTS_DIS to 0
IIC ¹¹⁾	I_{IICDDC}	580	μA	Set PMCON1.IIC_DIS to 0

1) Modules that are controllable by programming the register PMCON1.

2) Not subject to production test, verified by design/characterisation.

3) Baseload current is measured when the device is running in user mode with an endless loop in the flash memory. All modules in register PMCON1 are disabled.

4) ADC active current is measured with: module enable, ADC analog clock at 8MHz, running in parallel conversion request in autoscan mode for 4 channels

5) SSC active current is measured with: module enabled, running in loop back mode at a baud rate of 1 MBaud

6) CCU6 active current is measured with: module enabled, all timers running in 8 MHz, 6 PWM outputs are generated.

Electrical Parameters

- 7) Timer 2 active current is measured with: module enabled, timer running in 8 MHz
- 8) MDU active current is measured with: module enabled, division operation was performed.
- 9) CORDIC active mode is measured with: module enabled, circular mode was selected for the calculation.
- 10) LEDTSCU active current is measured with: module enabled, counter running in 8 MHz.
- 11) IIC active current is measured with: module enabled, performing a master transmit with the master clock running at 400 KHz.

3.3 AC Parameters

The electrical characteristics of the AC Parameters are detailed in this section.

3.3.1 Testing Waveforms

The testing waveforms for rise/fall time, output delay and output high impedance are shown in [Figure 11](#), [Figure 12](#) and [Figure 13](#).

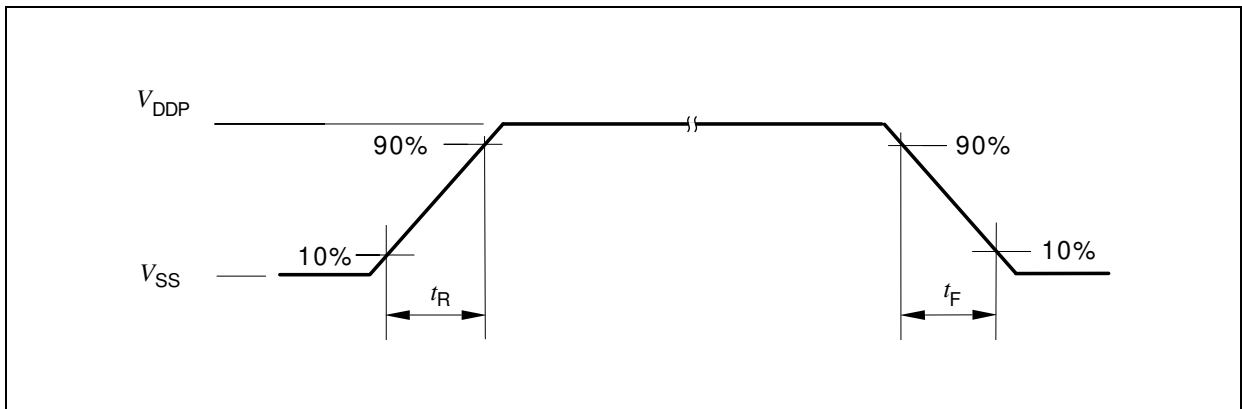

Figure 11 Rise/Fall Time Parameters

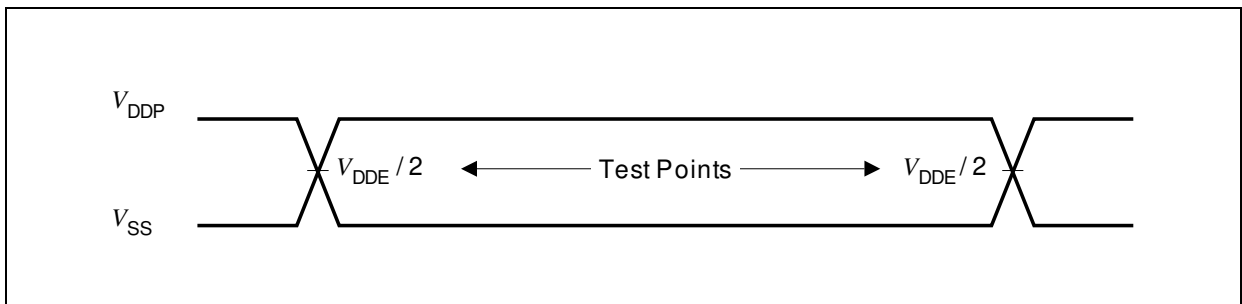

Figure 12 Testing Waveform, Output Delay

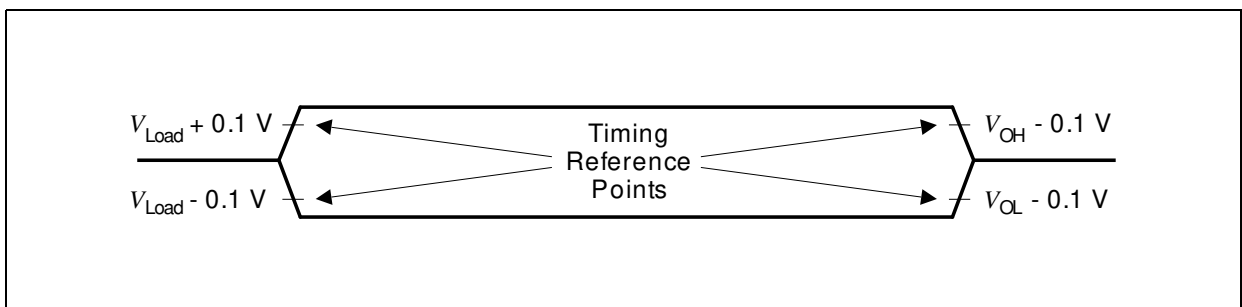

Figure 13 Testing Waveform, Output High Impedance

3.3.2 Output Rise/Fall Times

Table 18 provides the characteristics of the output rise/fall times in the XC835/836.

Table 18 Output Rise/Fall Times Parameters (Operating Conditions apply)

Parameter	Symbol	Limit Values		Unit	Test Conditions
		Min.	Max.		
Rise/fall times on High Current Pad Type A ¹⁾²⁾	t_{HCPR} , t_{HCPF}	–	15	ns	20 pF @ Fast edge (5 V) ³⁾ .
		–	150	ns	20 pF @ Slow Edge (5 V) ³⁾ .
		–	25	ns	20 pF @ Fast edge (3.3 V) ⁴⁾ .
		–	300	ns	20 pF @ Slow edge (3.3 V) ⁴⁾ .
Rise/fall times on High Current Pad Type B ¹⁾²⁾	t_R , t_F	–	10	ns	20 pF ³⁾⁴⁾ (5 V & 3.3 V).
Rise/fall times on Standard Pad ¹⁾²⁾	t_R , t_F	–	10	ns	20 pF ³⁾⁴⁾ (5 V & 3.3 V).

- 1) Rise/Fall time parameters are taken with 10% - 90% of supply.
- 2) Not all parameters are 100% tested, but are verified by design/characterisation and test correlation.
- 3) Additional rise/fall time valid for $C_L = 20 \text{ pF} - C_L = 100 \text{ pF}$ @ 0.125 ns/pF at 5 V supply voltage.
- 4) Additional rise/fall time valid for $C_L = 20 \text{ pF} - C_L = 100 \text{ pF}$.@ 0.225 ns/pF at 3.3 V supply voltage.

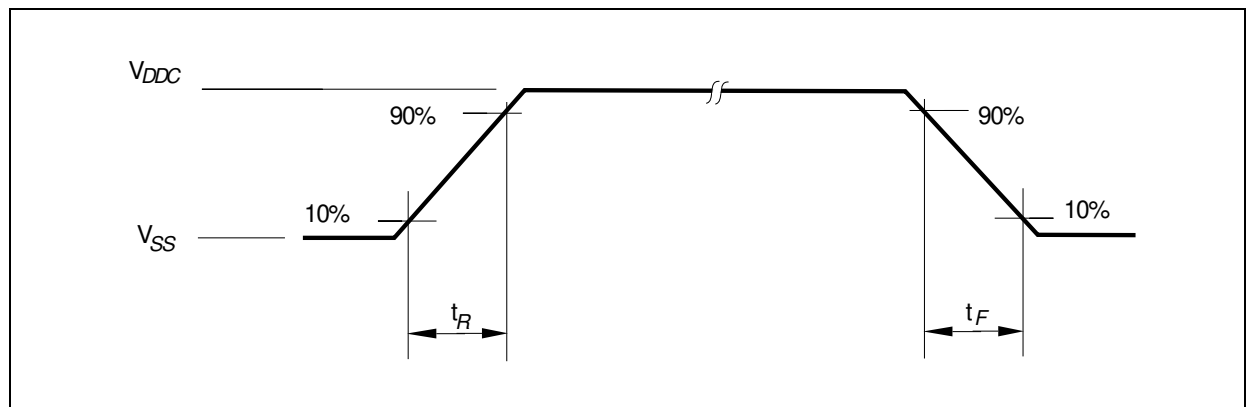

Figure 14 Rise/Fall Times Parameters

3.3.3 Oscillator Timing and Wake-up Timing

Table 19 provides the characteristics of the power-on reset, PLL and wake-up timings in the XC835/836.

Table 19 Power-On Reset Wake-up Timing¹⁾ (Operating Conditions apply)

Parameter	Symbol		Limit Values			Unit	Test Conditions
			Min.	Typ.	Max.		
48 MHz Oscillator start-up time	$t_{48\text{MOSCST}}$	CC	–	–	13	μs	
75 KHz Oscillator start-up time	$t_{75\text{KOSCST}}$	CC	–	–	800	μs	
32 KHz external oscillator start-up time ²⁾	$t_{32\text{KOSCST}}$	CC	–	–	1	s	
Flash initialization time	t_{FINT}	CC	–	160	–	μs	

1) Not subject to production test, verified by design/characterisation.

2) The external circuitry has to be optimized by the user and checked for negative resistance as recommended and specified by the crystal supplier.

3.3.4 On-Chip Oscillator Characteristics

Table 20 provides the characteristics of the 48 MHz oscillator in the XC835/836.

Table 20 48 MHz Oscillator Characteristics (Operating Conditions apply)

Parameter	Symbol	Limit Values			Unit	Test Conditions
		Min.	Typ.	Max.		
Nominal frequency	f_{NOM} CC	-0.5 %	48	+0.5%	MHz	under nominal conditions ¹⁾ after trimming
Long term frequency deviation	Δf_{LT} CC	-2.0	–	3.0	%	with respect to f_{NOM} , over lifetime and temperature (0 °C to 85 °C)
		-4.5	–	4.5	%	with respect to f_{NOM} , over lifetime and temperature (-40 °C to 125 °C)
Short term frequency deviation (over V_{DDC})	Δf_{ST} CC	-1	–	1	%	with respect to f_{NOM} , within one LIN message (< 10 ms ... 100 ms)

1) Nominal condition: $V_{\text{DDC}} = 2.5 \text{ V}$, $T_{\text{A}} = +25^\circ\text{C}$.

Electrical Parameters

Table 21 provides the characteristics of the 75 kHz oscillator in the XC835/836.

Table 21 75 kHz Oscillator Characteristics (Operating Conditions apply)

Parameter	Symbol	Limit Values	Unit	Test Conditions
Nominal frequency	f_{NOM} CC	-1% 75 +1%	KHz	under nominal conditions ¹⁾ after trimming
Long term frequency deviation	Δf_{LT} CC	-4.5 – 4.5	%	with respect to f_{NOM} , over lifetime and temperature (-40 °C to 125 °C)
Short term frequency deviation	Δf_{ST} CC	-1.5 – 1.5	%	with respect to f_{NOM} , over V_{DDC}

1) Nominal condition: $V_{\text{DDC}} = 2.5 \text{ V}$, $T_{\text{A}} = + 25^{\circ}\text{C}$.

3.3.5 SSC Timing

3.3.5.1 SSC Master Mode Timing

Table 22 provides the SSC master mode timing in the XC835/836.

Table 22 SSC Master Mode Timing¹⁾ (Operating Conditions apply; CL = 50 pF)

Parameter	Symbol		Limit Values		Unit
			Min.	Max.	
SCLK clock period	t_0	CC	$2 * T_{SSC}^{2)}$	–	ns
MTSR delay from SCLK	t_1	CC	0	3	ns
MRST set-up to SCLK	t_2	SR	32	–	ns
MRST hold from SCLK	t_3	SR	0	–	ns

1) Not subject to production test, verified by design/characterisation.

2) $T_{SSCmin} = T_{CPU} = 1/f_{CPU}$. When $f_{CPU} = 24$ MHz, $t_0 = 83.3$ ns. T_{CPU} is the CPU clock period.

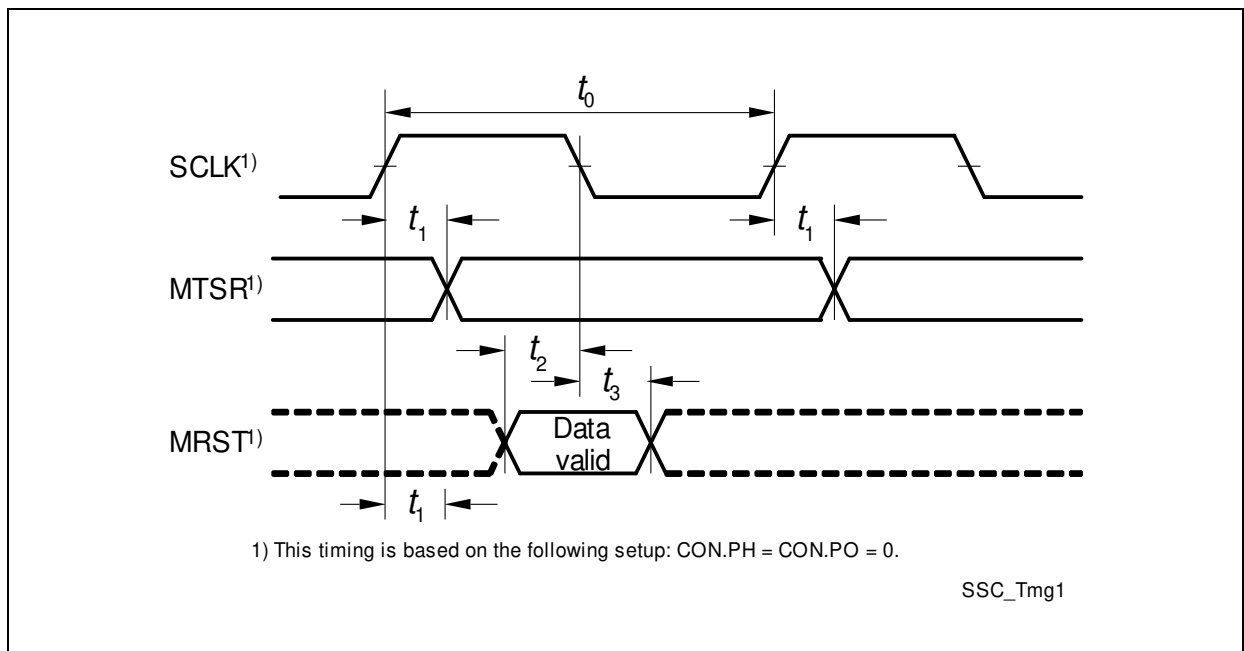

Figure 15 SSC Master Mode Timing

3.3.5.2 SSC Slave Mode Timing

Table 23 provides the SSC slave mode timing in the XC835/836.

Table 23 SSC Slave Mode Timing¹⁾ (Operating Conditions apply; CL = 50 pF)

Parameter	Symbol		Limit Values		Unit
			Min.	Max.	
SCLK clock period	t_0	SR	$4 * T_{SSC}^{2)}$	–	ns
MRST delay from SCLK	t_1	CC	0	29	ns
MTSR set-up to SCLK	t_2	SR	32	–	ns
MTSR hold from SCLK	t_3	SR	0	–	ns

- 1) Not subject to production test, verified by design/characterisation.
- 2) $T_{SSCmin} = T_{CPU} = 1/f_{CPU}$. When $f_{CPU} = 24$ MHz, $t_0 = 166.7$ ns. T_{CPU} is the CPU clock period.

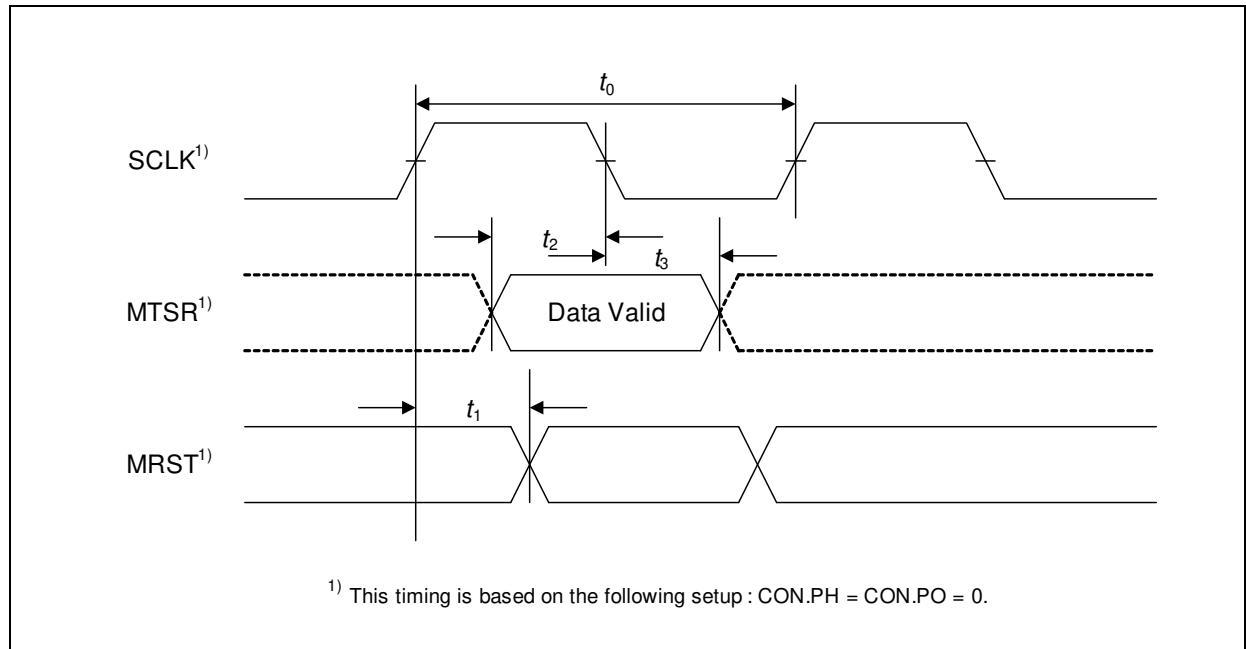

Figure 16 SSC Slave Mode Timing

3.3.6 SPD Timing

The SPD interface will work with standard SPD tools having a sample/output clock frequency deviation of +/- 5% or less. For further details please refer to application note AP24004 in section SPD Timing Requirements.

Note: These parameters are no subject to product test but verified by design and/or characterization.

Note: Operating Conditions apply.

4 Package and Quality Declaration

Chapter 4 provides the information of the XC835/836 package and reliability section.

4.1 Package Parameters

Table 24 provides the thermal characteristics of the packages used in XC835 and XC836 respectively.

Table 24 Thermal Characteristics of the Packages

Parameter	Symbol	CC	Limit Values		Unit	Package Types
			Min.	Max.		
Thermal resistance junction case ¹⁾	R_{TJC}	CC	-	30.8	K/W	PG-DSO-24-1
			-	27.0	K/W	PG-TSSOP-28-1
			-	20.2	K/W	PG-TSSOP-28-12
Thermal resistance junction lead ¹⁾	R_{TJL}	CC	-	30.5	K/W	PG-DSO-24-1
			-	195.3	K/W	PG-TSSOP-28-1
			-	41	K/W	PG-TSSOP-28-12

1) The thermal resistances between the case and the ambient (R_{TCA}), the lead and the ambient (R_{TLA}) are to be combined with the thermal resistances between the junction and the case (R_{TJC}), the junction and the lead (R_{TJL}) given above, in order to calculate the total thermal resistance between the junction and the ambient (R_{TJA}). The thermal resistances between the case and the ambient (R_{TCA}), the lead and the ambient (R_{TLA}) depend on the external system (PCB, case) characteristics, and are under user responsibility.

The junction temperature can be calculated using the following equation: $T_J = T_A + R_{TJA} \times P_D$, where the R_{TJA} is the total thermal resistance between the junction and the ambient. This total junction ambient resistance R_{TJA} can be obtained from the upper four partial thermal resistances, by

- a) simply adding only the two thermal resistances (junction lead and lead ambient), or
- b) by taking all four resistances into account, depending on the precision needed.

4.2 Package Outline

Figure 17 and Figure 18 shows the package outlines of the XC835 (DSO-24-1) and XC836 (TSSOP-28-1 and TSSOP-28-12) devices respectively.

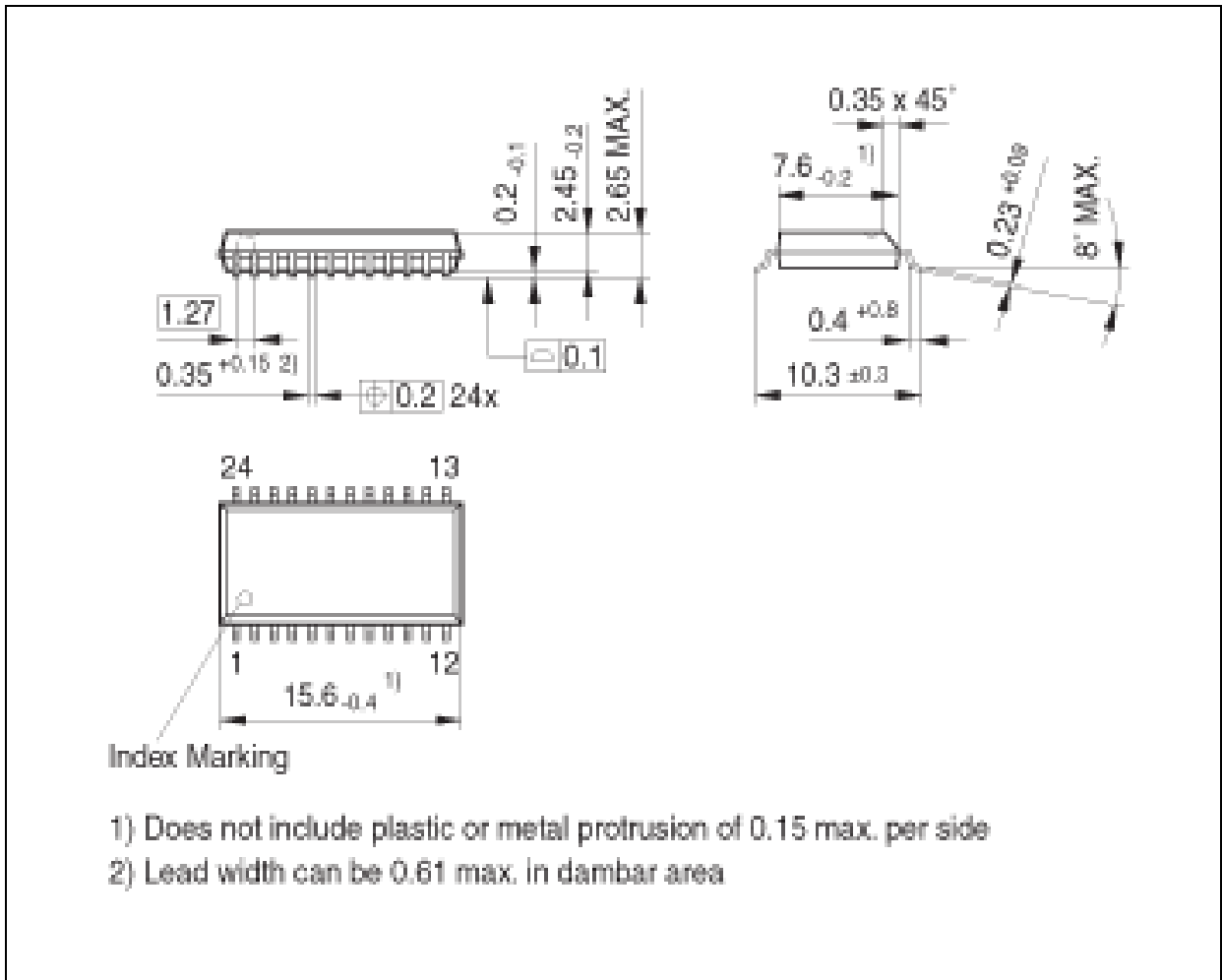

Figure 17 PG-DSO-24-1 Package Outline

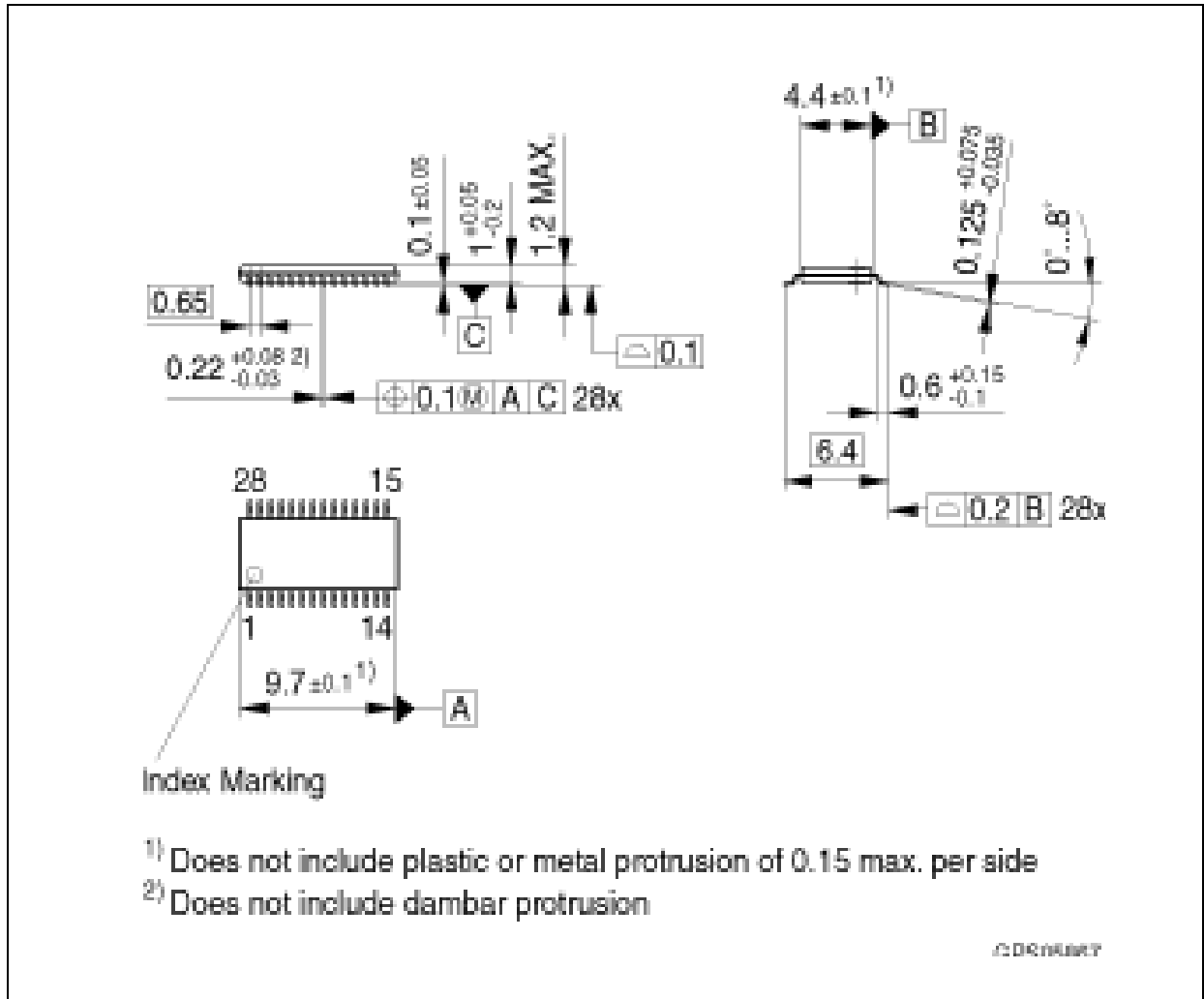

Figure 18 PG-TSSOP-28-1 Package Outline

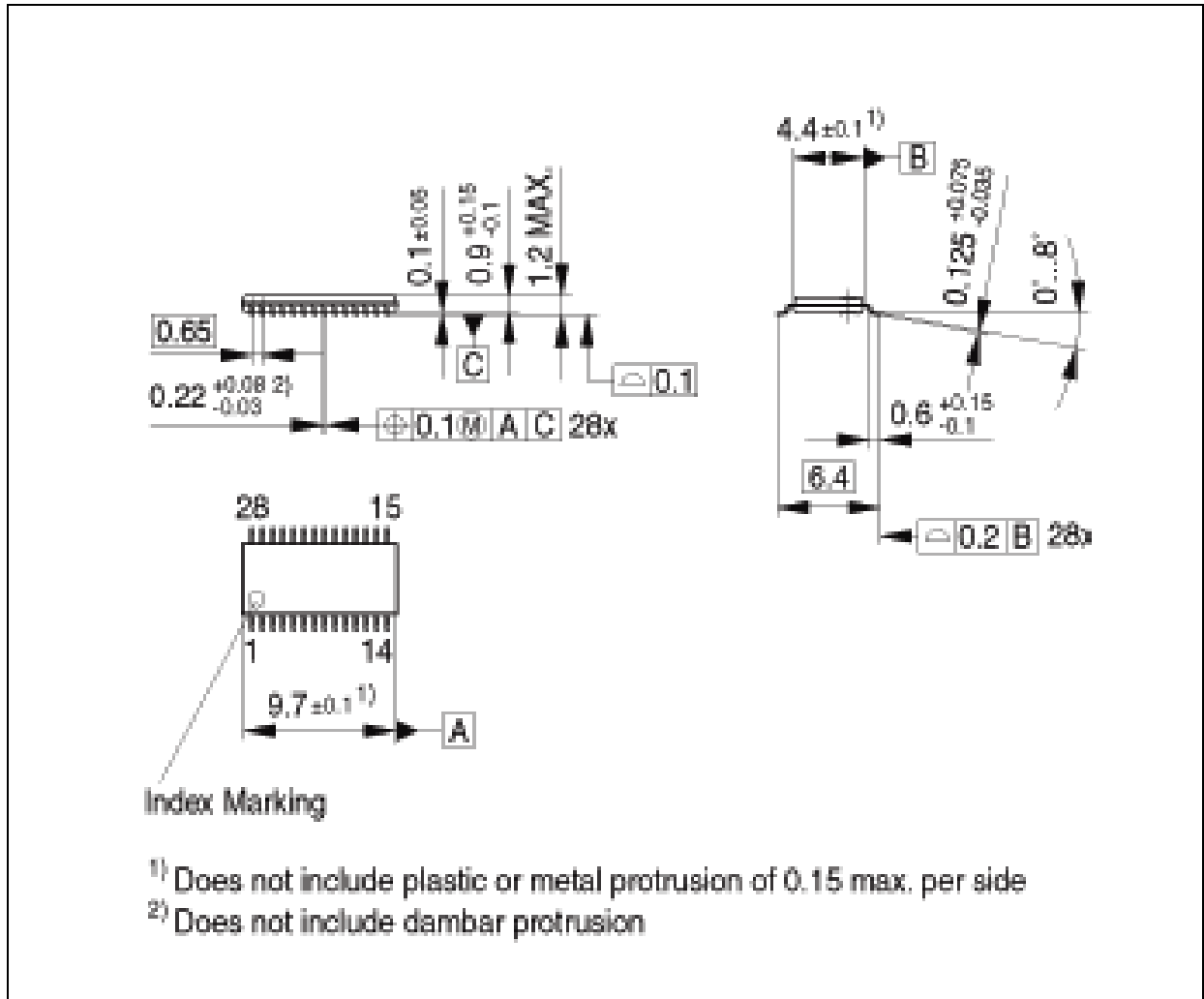

Figure 19 PG-TSSOP-28-12 Package Outline

Package and Quality Declaration
4.3 Quality Declaration

Table 25 shows the characteristics of the quality parameters in the XC835/836.

Table 25 Quality Parameters

Parameter	Symbol	Limit Values		Unit	Notes
		Min.	Max.		
Operation Lifetime when the device is used at the three stated T_J ¹⁾	t_{OP1}	-	1500	hours	$T_J = 150^\circ\text{C}$
		-	15000	hours	$T_J = 110^\circ\text{C}$
		-	1500	hours	$T_J = -40^\circ\text{C}$
Operation Lifetime when the device is used at the stated T_J ¹⁾	t_{OP2}	-	131400	hours	$T_J = 27^\circ\text{C}$
ESD susceptibility according to Human Body Model (HBM)	V_{HBM}	-	2000	V	Conforming to EIA/JESD22-A114-B ²⁾
ESD susceptibility according to Charged Device Model (CDM) pins	V_{CDM}	-	500	V	Conforming to JESD22-C101-C ²⁾

1) This lifetime refers only to the time when device is powered-on.

2) Not all parameters are 100% tested, but are verified by design/characterisation and test correlation.

www.infineon.com

Published by Infineon Technologies AG