

Ethernet Switch Description

Part number	RES-SCE-8MG
Description	Managed miniature portable Ethernet switch - 8 Gigabit ports
Standards	MIL-STD-1275, MIL-STD-704A, MIL-STD-461E, MIL-STD-810F GM, IP67/68, RTCA/DO-160F
Input Voltage	24Vdc Nominal (16-36 VDC)

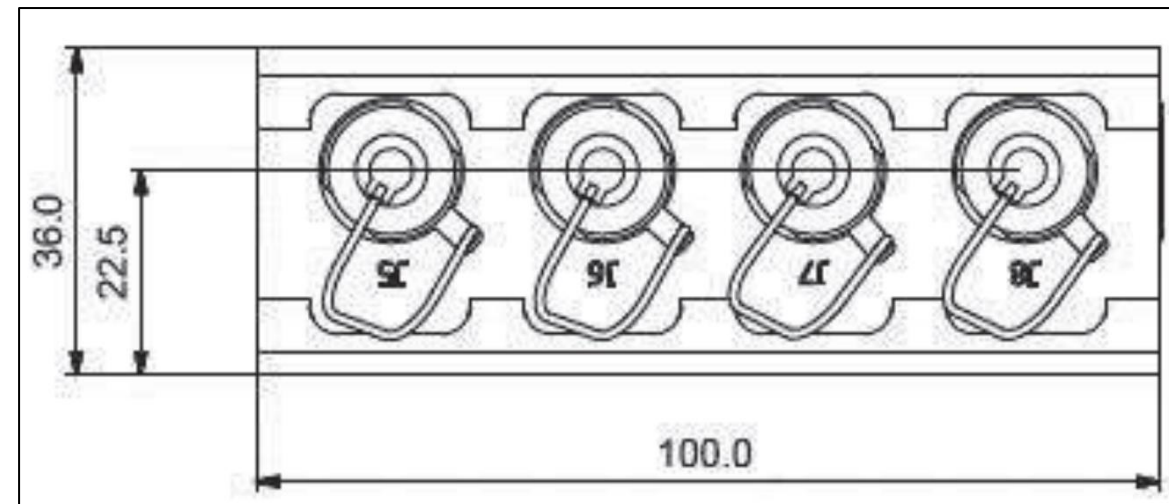

RES-SCE-8MG
(For Dimensions refer Pic A,B,C)



Pic A

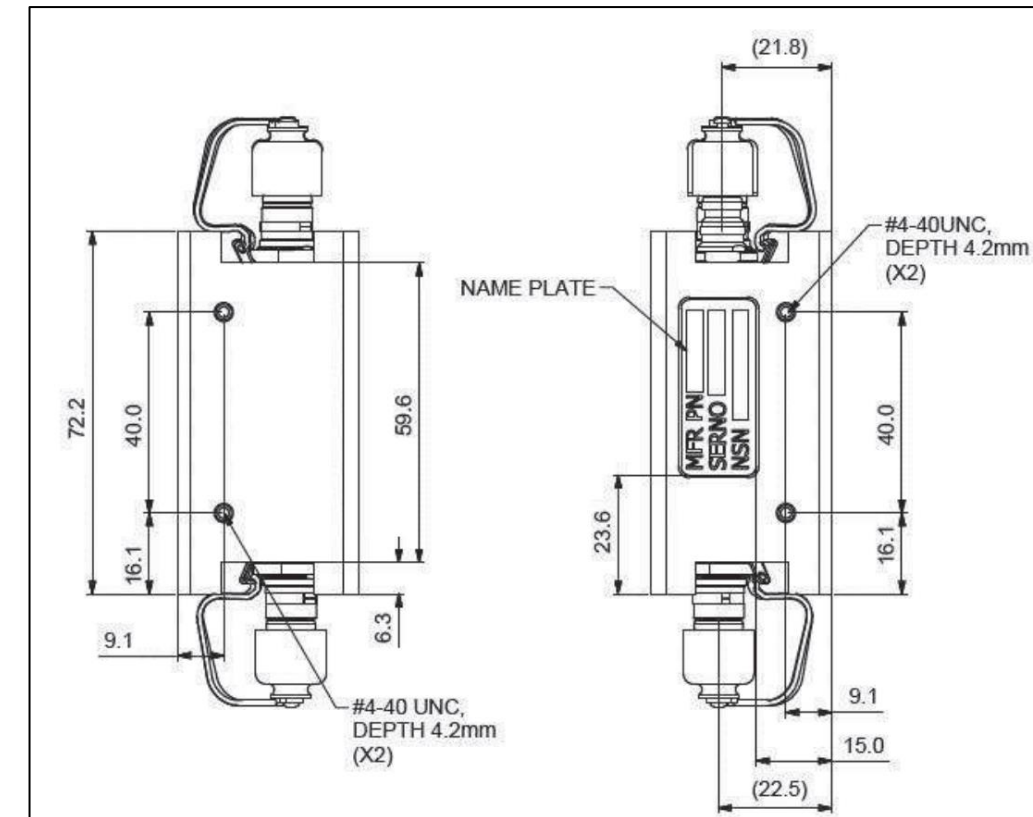

Pic B

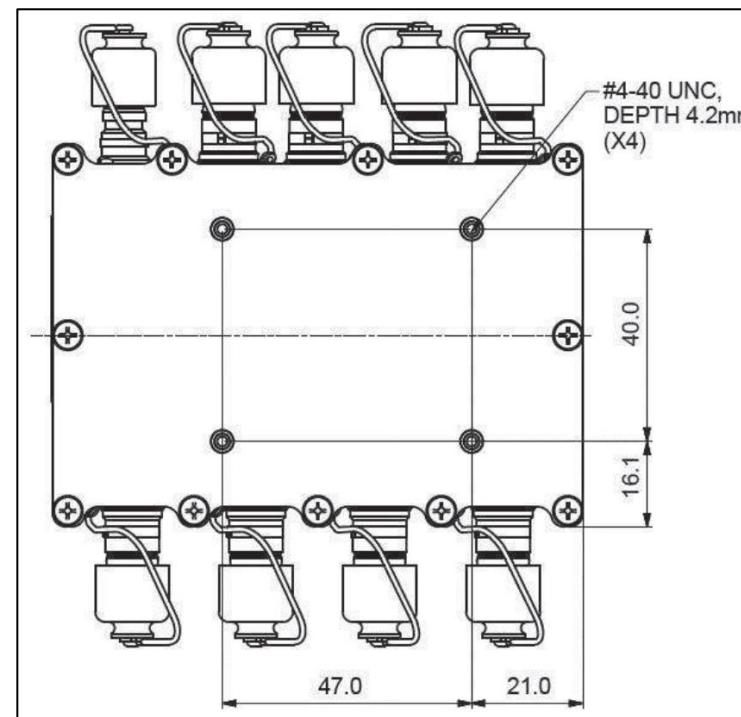

Pic C

Plan à compléter si nécessaire
(marquages, tolérances spécifiques...)

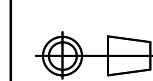

DESSINE PAR :

Prasad M
09/07/20

TECHNIQUE :

Sajeesh V.S
09/07/20

Amphenol Socapex

B.P.29 74311 THYEZ CEDEX

BON POUR ACCORD FABRICATION :

DATE :

KIT RES-SCE-8MG with cables

REPLACE LE :-

INDICE :-

INDICE : → A

MISE A JOUR :-

Nom du client :
+ Programme :

DEV: 178

191-PLC-973-00

2/8

Cable assembly for power supply : RES-SCE-8MG-CBL-PWR-2M-B4

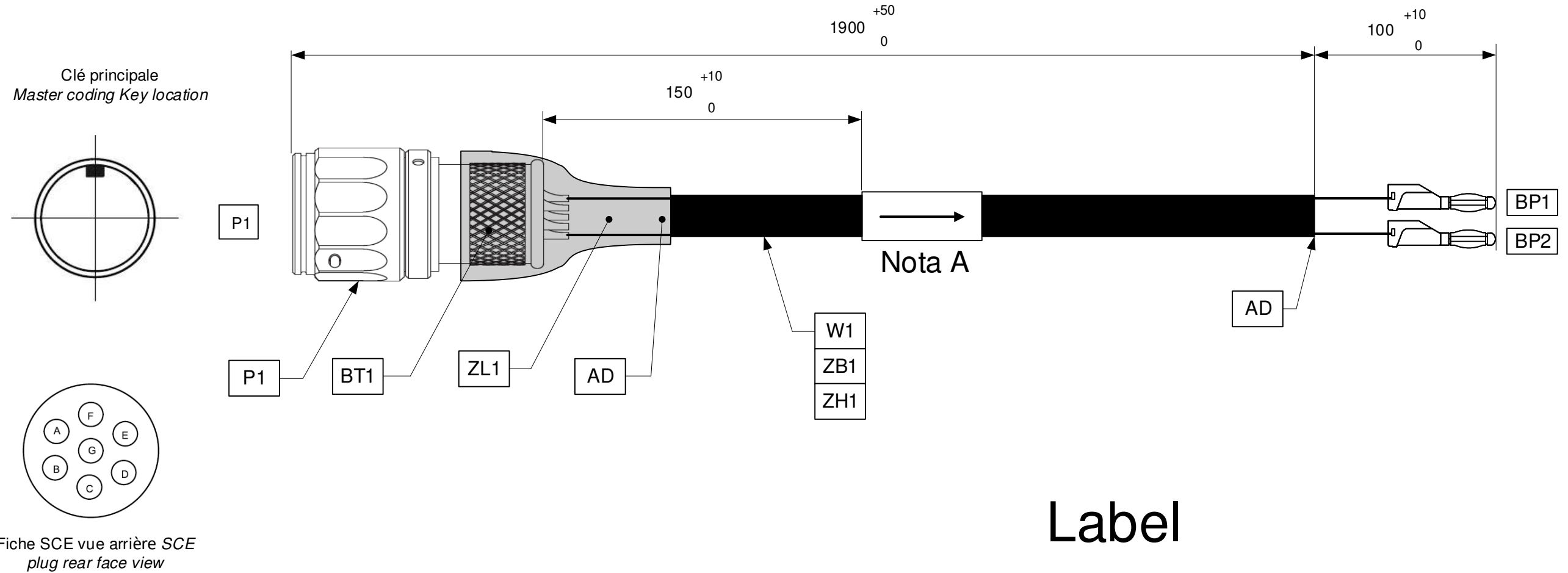

Label

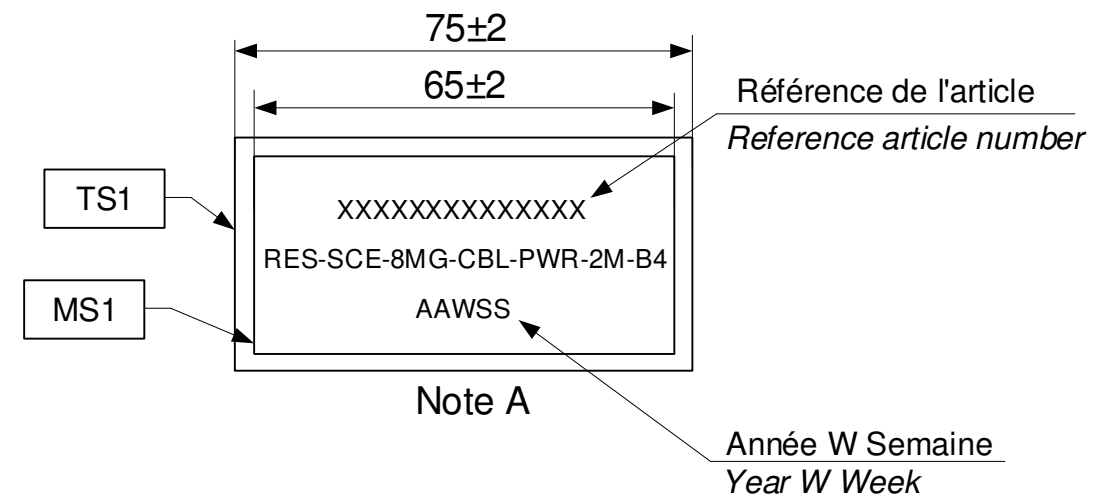

Notes:

1. All dimensions are in millimeter.
Les cotes sont en millimètre.
2. Continuity & insulation resistance test on each S/N.
Test de continuité & résistance d'isolement sur chaque S/N.
3. Packed in sealed bag
Emballé dans un sac étanche.
4. Shielding braid tighten to the connector shell.
Tresse serrée sur la carrosserie.

**Plan à compléter si nécessaire
(marquages, tolérances spécifiques...)**

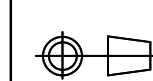

DESSINE PAR :

Prasad M
09/07/20

TECHNIQUE :

Sajeesh V.S
09/07/20

Amphenol Socapex

B.P.29 74311 THYEZ CEDEX

KIT RES-SCE-8MG with cables

REPLACE LE :- INDICE :-

INDICE :-> A MISE A JOUR :-

BON POUR ACCORD FABRICATION :

DATE :

Nom du client :
+ Programme :

DEV: 178

191-PLC-973-00

3/8

Cable assembly for power supply : RES-SCE-8MG-CBL-PWR-2M-B4

Wiring diagram

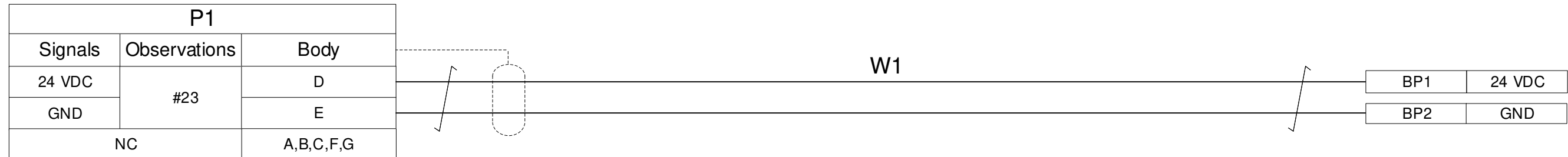
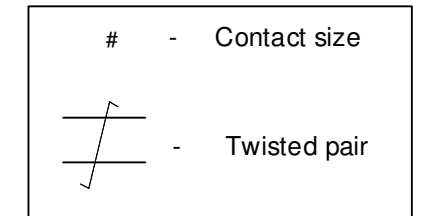

Bill of material

Sr no	Designation	Component type	Manufacturer Part number	Manufacturer	Unit Qty	UOM
1	P1	Connector	SCE2-B-L1K06-07PN	Amphenol	1.00	EA
2	BP1	Banana Plug	FK15S RED	Schützinger	1.00	EA
3	BP2	Banana Plug	FK15S BLACK	Schützinger	1.00	EA
4	W1	Wire	KU03-22-9	Nexans	2.00	M
5	ZB1	Braid	TB13-T-63	Forissier	2.00	M
6	ZH1	HST	DR25 1/4-0M	Tyco	2.00	M
7	BT1	Band Tie	600-057	Glenair	1.00	EA
8	ZL1	Boot	202K121-25-0	Tyco	1.00	EA
9	AD	Adhesive	S1125-KIT-8	Tyco	As.Req	EA
10	MS1	HST	RNF100 1/4-YELLOW	Tyco	0.07	M
11	TS1	HST	RNF 100 1/4 -TRANSP	Tyco	0.08	M

Plan à compléter si nécessaire
(marquages, tolérances spécifiques...)

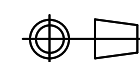

DESSINE PAR :

Prasad M
09/07/20

TECHNIQUE :

Sajeesh V.S
09/07/20

Amphenol Socapex

B.P.29 74311 THYEZ CEDEX

KIT RES-SCE-8MG with cables

BON POUR ACCORD FABRICATION :

DATE :

REPLACE LE :- INDICE :-

Nom du client :
+ Programme :

INDICE : → A MISE A JOUR :-

DEV: 178

191-PLC-973-00

4/8

Cable assembly for management port : RESSCE8MG-CBL-MNG-1M

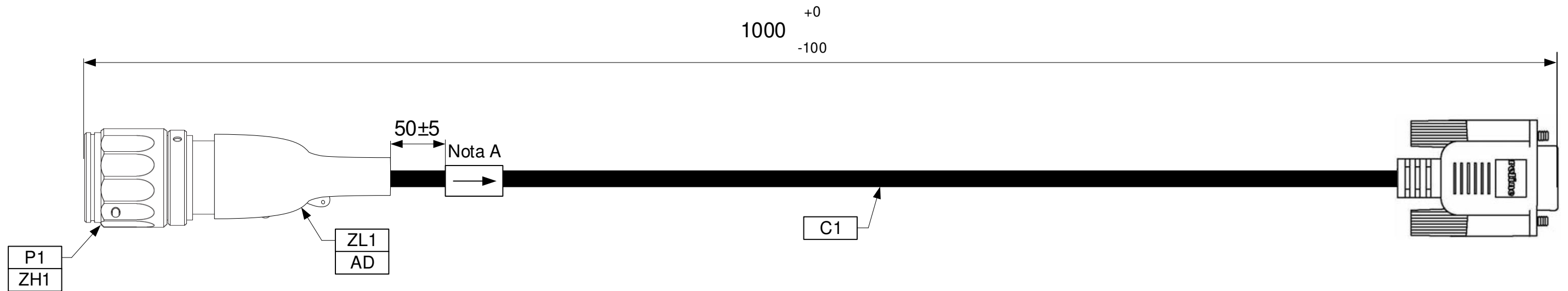

Notes:

- All dimensions are in millimeter.
Les cotes sont en millimètre.
- Continuity & insulation resistance test on each S/N.
Test de continuité & résistance d'isolement sur chaque S/N.
- Packed in sealed bag
Emballé dans un sac étanche.
- Use HST (ZH1) over solder contacts at P1 end.
Utilisez HST (ZH1) sur les contacts de soudure à l'extrémité P1.
- Do not terminate the cable shield over P1 Connector.
Ne terminez pas le blindage du câble sur le connecteur P1.

Label

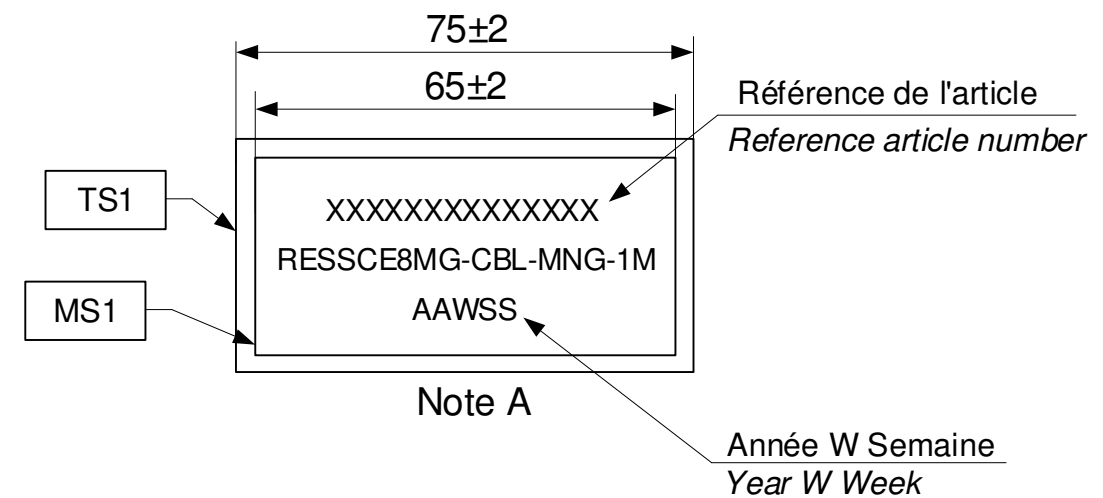

**Plan à compléter si nécessaire
(marquages, tolérances spécifiques...)**

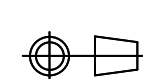

DESSINE PAR :

Prasad M
09/07/20

TECHNIQUE :

Sajeesh V.S
09/07/20

Amphenol Socapex

B.P.29 74311 THYEZ CEDEX

KIT RES-SCE-8MG with cables

REPLACE LE :- INDICE :-

INDICE :-> A MISE A JOUR :-

BON POUR ACCORD FABRICATION :

DATE :

Nom du client :
+ Programme :

DEV: 178

191-PLC-973-00

5/8

Cable assembly for management port : RESSCE8MG-CBL-MNG-1M

Wiring diagram

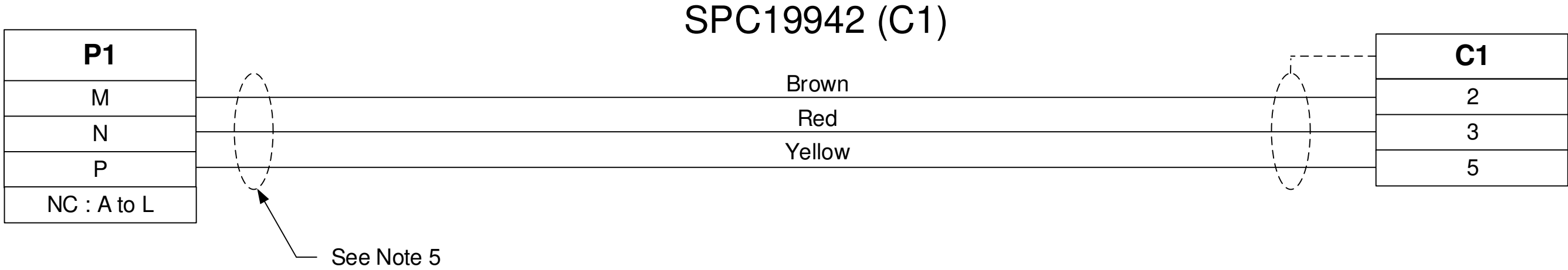

Bill of Material

Sr no	Designation	Component type	Manufacturer Part number	Manufacturer	Unit Qty	UOM
1	P1	Connector	SCE2-B-L1K07-14PN	Amphenol	1.00	EA
2	ZL1	Boot	202K121-25-0	Tyco	1.00	EA
3	AD	Adhesive	S1125-KIT-8	Tyco	AR	EA
4	C1	Cable	SPC19942	Multicomp	0.50	EA
5	MS1	HST	RNF100 1/4-YELLOW	Tyco	0.07	M
6	TS1	HST	RNF100 3/8-TRANSP	Tyco	0.08	M
7	ZH1	HST	RNF100 3/64-BLACK	Tyco	0.03	M

Plan à compléter si nécessaire
(marquages, tolérances spécifiques...)

	DESSINE PAR :	TECHNIQUE :
	Prasad M 09/07/20	Sajeesh V.S 09/07/20
KIT RES-SCE-8MG with cables		
DEV: 178		

Amphenol Socapex

B.P.29 74311 THYEZ CEDEX

REPLACE LE :-	INDICE :-
INDICE :-> A	MISE A JOUR :-

191-PLC-973-00

6/8

BON POUR ACCORD FABRICATION :	DATE :
Nom du client :	
+ Programme :	

Cable assembly for LAN ports : RESSCE8MG-CBL-ETH-RJ45-2M

Clé principale
Master coding Key location

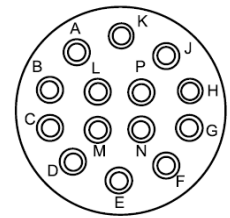
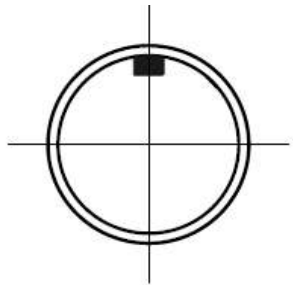

Fiche SCE vue arrière SCE
plug rear face view

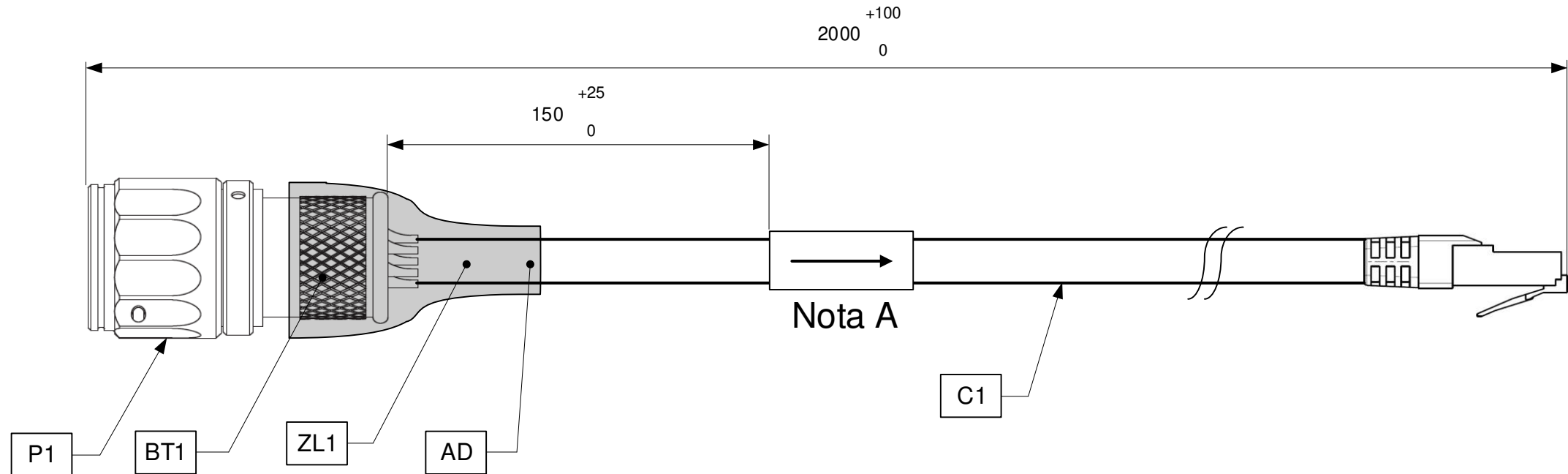

Label

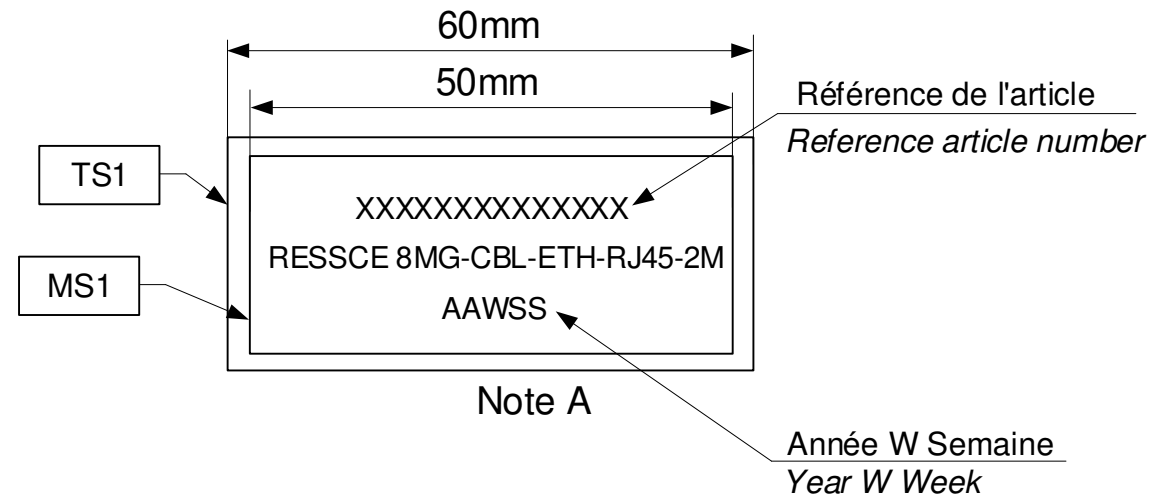

Notes:

1. All dimensions are in millimeter.
Les cotes sont en millimètre.
2. Continuity & insulation resistance test on each S/N.
Test de continuité & résistance d'isolement sur chaque S/N.
3. Packed in sealed bag
Emballé dans un sac étanche.
4. Shielding braid tighten to the connector shell.
Tresse serrée sur la carrosserie.

**Plan à compléter si nécessaire
(marquages, tolérances spécifiques...)**

	DESSINE PAR :	TECHNIQUE :
	Prasad M 09/07/20	Sajeesh V.S 09/07/20
KIT RES-SCE-8MG with cables		
DEV: 178		

Amphenol Socapex

B.P.29 74311 THYEZ CEDEX

REPLACE LE :- INDICE :-

INDICE :-> A MISE A JOUR :-

191-PLC-973-00

Cable assembly for LAN ports : RESSCE8MG-CBL-ETH-RJ45-2M

Wiring diagram

Brochage selon TIA 568B/ Pinout type TIA 568B

SCE2	RJ-45	Signal	Couleur / Color
A	1	Tx2	Blanc / White Orange / Orange
B	2	Rx2	Orange / Orange
C	3	Tx3	Blanc / White Vert / Green
D	4	Rx1	Bleu / Blue
E	5	Tx1	Blanc / White Bleu / Blue
F	6	Rx3	Vert / Green
G	7	Tx4	Blanc / White Marron / Brown
H	8	Rx4	Marron / Brown
J - N	Not connected		

Bill of material

Sr no	Designation	Component type	Manufacturer Part number	Manufacturer	Unit Qty	UOM
1	P1	Connector	SCE2-B-L1K07-14PN	Amphenol	1.00	EA
2	C1	Cordset with RJ45	RJF SFTP 5E 0305	Amphenol	1.00	EA
3	BT1	Band Tie	600-057	Glenair	1.00	EA
4	ZL1	Boot	202K121-25-0	Tyco	1.00	EA
5	AD	Adhesive	S1125-KIT-8	Tyco	As. Req	EA
6	MS1	HST	RNF100 3/8-4	Tyco	0.05	M
7	TS1	HST	RNF 100 3/8 -X	Tyco	0.06	M

Plan à compléter si nécessaire
(marquages, tolérances spécifiques...)

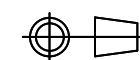

DESSINE PAR :

Prasad M
09/07/20

TECHNIQUE :

Sajeesh V.S
09/07/20

Amphenol Socapex

B.P.29 74311 THYEZ CEDEX

BON POUR ACCORD FABRICATION :

DATE :

KIT RES-SCE-8MG with cables

REPLACE LE :- INDICE :-

Nom du client :
+ Programme :

DEV: 178

INDICE : → A MISE A JOUR :-

191-PLC-973-00

8/8