

Monaural Microphone Amplifier

■ GENERAL DESCRIPTION

The **NJM2781** is a monaural microphone amplifier IC with a standby function, and can vary a voltage gain by adjusting an external resistor.

Since the **NJM2781** operates with a low voltage range of +2.7V to +4.5V and is available in tiny packages of MSOP8(TVSP8)* and SSOP8, it is ideally suited for portable and handheld components.

■ PACKAGE OUTLINE



NJM2781RB1
MSOP8(TVSP8)



NJM2781V
(SSOP8)

■ FEATURES

- Operating Voltage +2.7V to +4.5 V
- Operating Current 1.8mA typ.
1μA max. (in Standby mode)
- Bipolar Technology
- Package Outline MSOP8(TVSP8) *
SSOP8

*MEET JEDEC MO-187-DA / THIN TYPE

■ BLOCK DIAGRAM

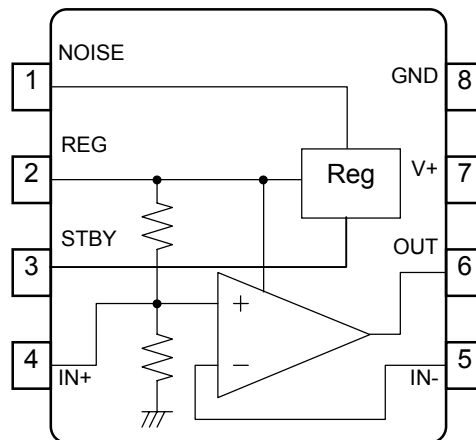

■ PIN FUNCTION

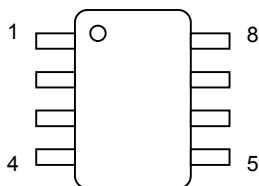

No.	SYMBOL	FUNCTION	No.	SYMBOL	FUNCTION
1	NOISE	Noise Bypass	5	IN-	Inverted Input
2	REG	Regulator Output	6	OUT	Output
3	STBY	Standby On/Off	7	V+	Power Supply
4	IN+	Non-Inverted Input	8	GND	Ground

■ ABSOLUTE MAXIMUM RATING (Ta=25°C)

PARAMETER	SYMBOL	RATING	UNIT
Supply Voltage	V ⁺	5	V
Power Dissipation	P _D	MSOP8(TVSP8):320, SSOP8:250	mW
Operating Temperature Range	Topr	-40 to 85	°C
Storage Temperature Range	Tstg	-40 to 125	°C

■ ELECTRICAL CHARACTERISTICS

(Ta=25°C, V⁺=2.8V, Vin=-40dBV, f=1kHz, R_L=9kΩ)

● Power Supply

PARAMETER	SYMBOL	TEST CONDITION	MIN.	TYP.	MAX.	UNIT
Operating Voltage	V ⁺		2.7	2.8	4.5	V
Operating Current 1	I _{cc1}	No signal, Standby		-	1	μA
Operating Current 2	I _{cc2}	No signal, Active		1.8	4	mA
Mic Power Supply Voltage	V _o	RL=6.8kΩ	2.3	2.42	2.54	V

● Amplifier

PARAMETER	SYMBOL	TEST CONDITION	MIN.	TYP.	MAX.	UNIT
Output Voltage	V _o		1.28	1.35	1.42	V
Voltage Gain	G _v	Test Circuit 1	24	25	26	dB
Maximum Output Voltage	V _{OM}	THD=0.1%	-2.7 (0.73)	-1.5 (0.84)	-	dBV (V _{rms})
Total Harmonic Distortion (THD+N)	THD		-	0.025	0.1	%
Output Noise	V _{NO}	Rg=600Ω, A-Weighted	-	-98 (12.6)	-90 (31.6)	dBV (μV _{rms})
Power Supply Ripple Rejection	PSRR	Rg=600Ω, Vripple=-20dBV	65	80	-	dB

● Control

PARAMETER	SYMBOL	TEST CONDITION	MIN.	TYP.	MAX.	UNIT
High Level Input Voltage	V _{IH}	STBY terminal	2	-	V ⁺	V
Low Level Input Voltage	V _{IL}	STBY terminal	0	-	0.5	V

■ Standby Mode Operation

Status	Control Terminal	IC Condition
	STBY	
Active	H	IC active
Standby	L, OPEN	IC standby

■ TEST CIRCUIT

Test Circuit 1 (Voltage Gain G_V , Maximum Output Voltage V_{OM} , Total Harmonic Distortion THD)

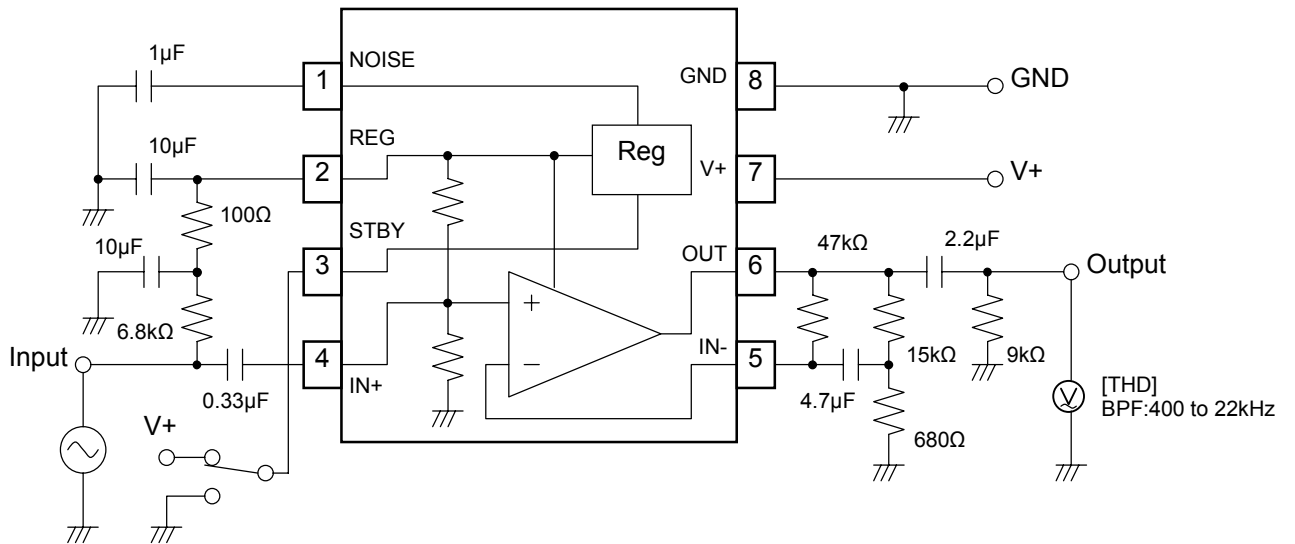

Test Circuit 2 (DC Output Voltage V_O , Output Noise V_{NO})

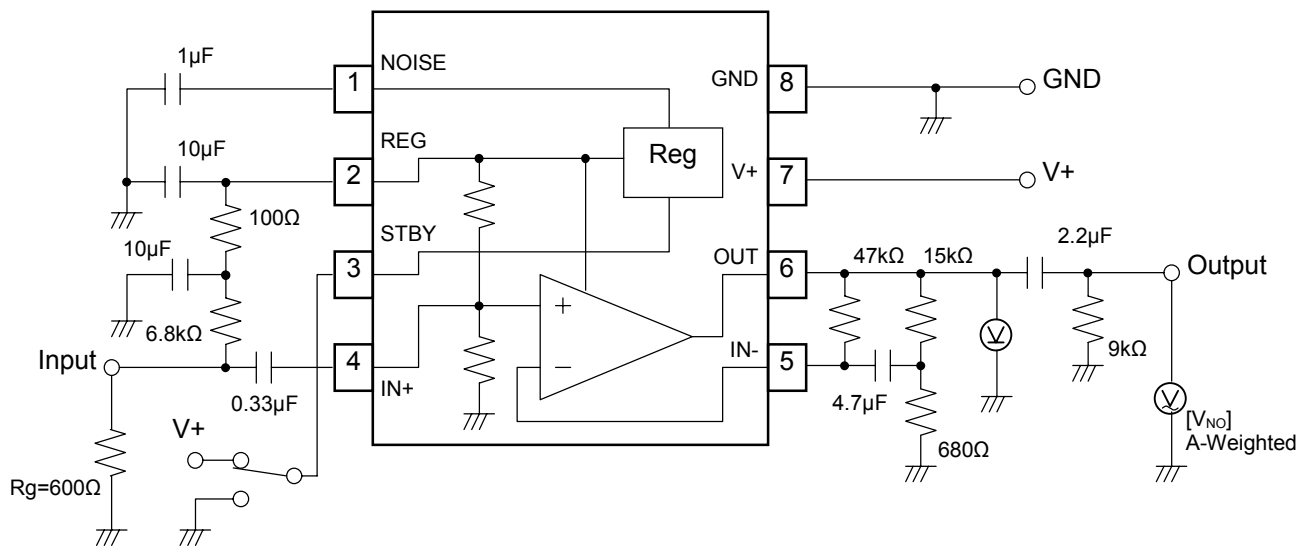

Test Circuit 3 (Operating Current I_{cc1}, I_{cc2})

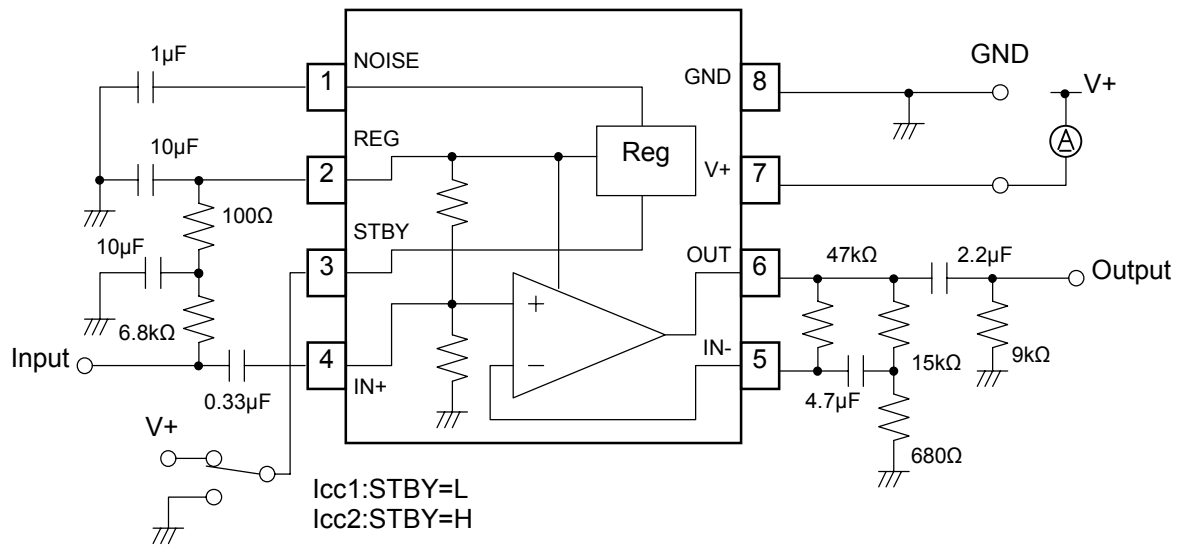

Test Circuit 4 (Mic Power Supply Voltage V_O)

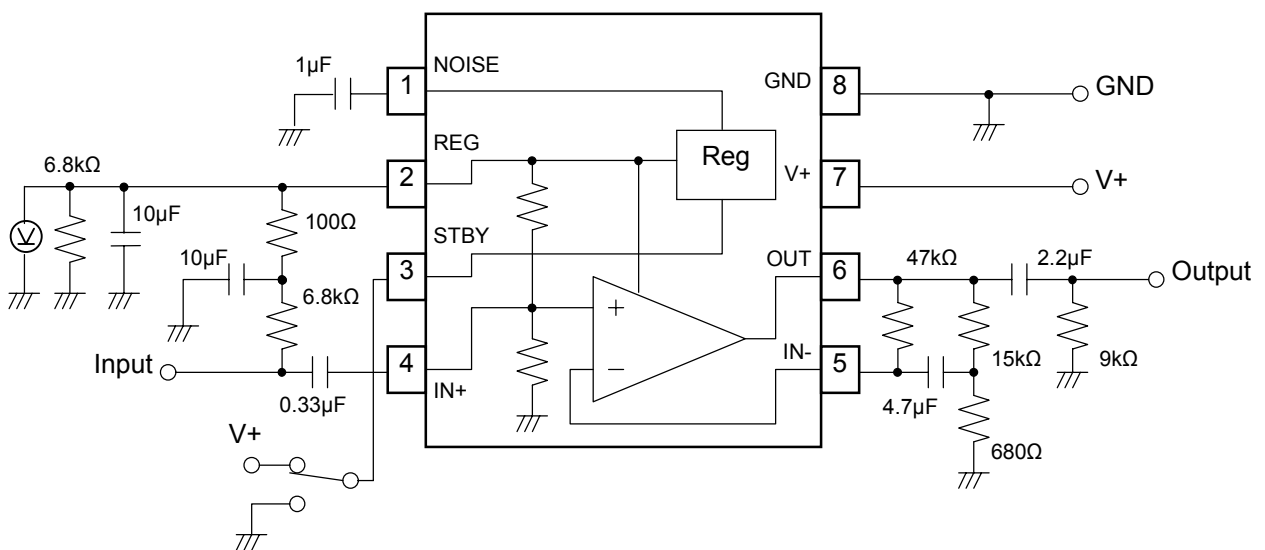

NJM2781

■ APPLICATION CIRCUIT

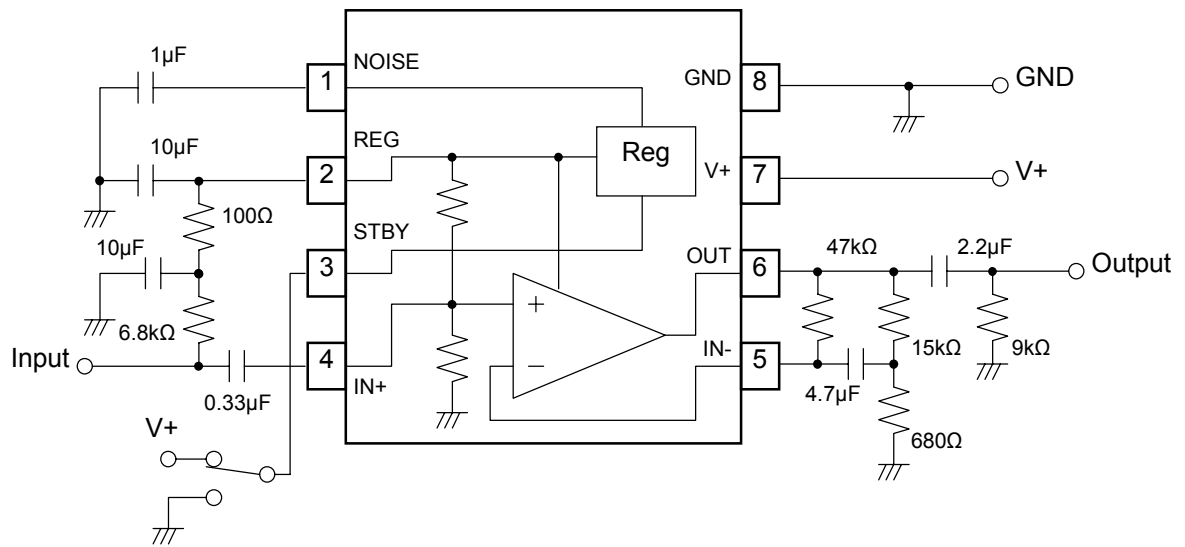

■ TERMINAL DESCRIPTION

PIN NO.	SYMBOL	FUNCTION	EQUIVALENT CIRCUIT	TERMINAL VOLTAGE
1	NOISE	Noise Bypass		0.54V
2	REG	Regulator Output		2.42V
3	STBY	Standby On/Off		0V
4	IN+	Non-Inverted Input		1.35V

NJM2781

■ TERMINAL DESCRIPTION

PIN NO.	SYMBOL	FUNCTION	EQUIVALENT CIRCUIT	TERMINAL VOLTAGE
5	IN-	Inverted Input		1.35V
6	OUT	Output		1.35V

■ TYPICAL CHARACTERISTICS

Operating Current vs. Power Supply Voltage (Standby)

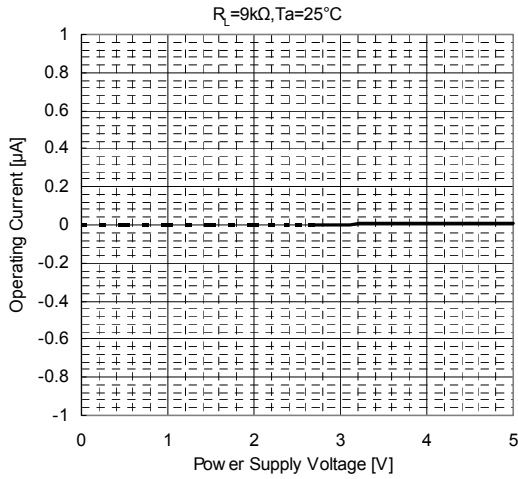

Operating Current vs. Ambient Temperature (Standby)

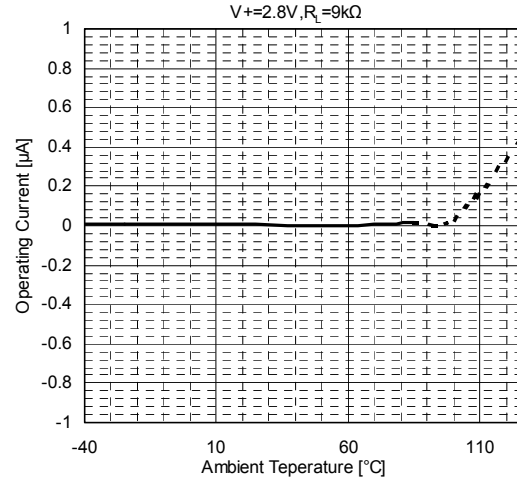

Operating Current vs. Power Supply Voltage (Active)

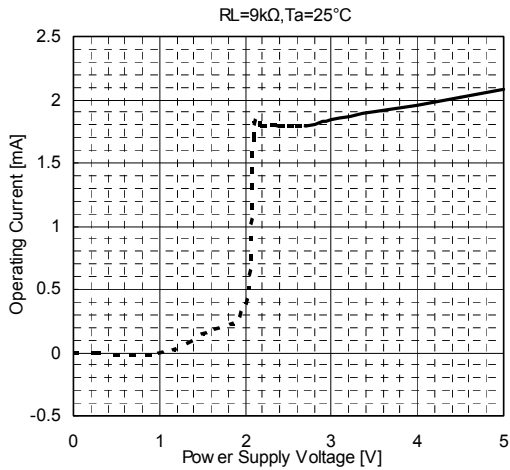

Operating Current vs. Ambient Temperature (Active)

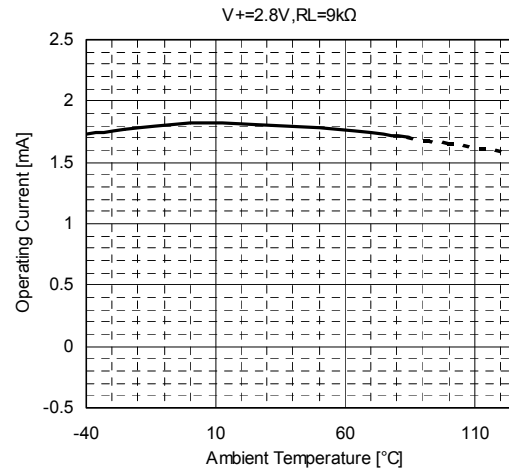

Operating Current vs. Standby Voltage

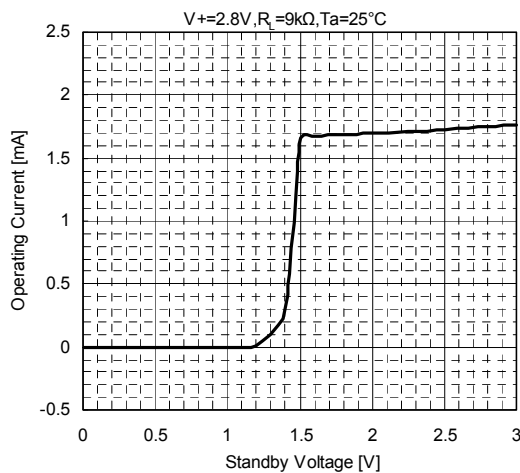

Output Voltage vs. Input Voltage (Standby)

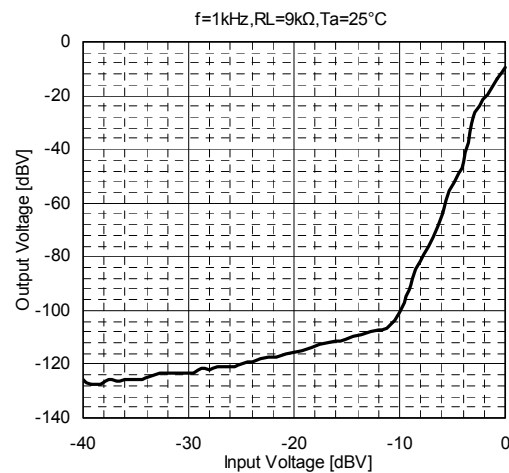

■ TYPICAL CHARACTERISTICS

Mic Power Supply Voltage vs. Power Supply Voltage

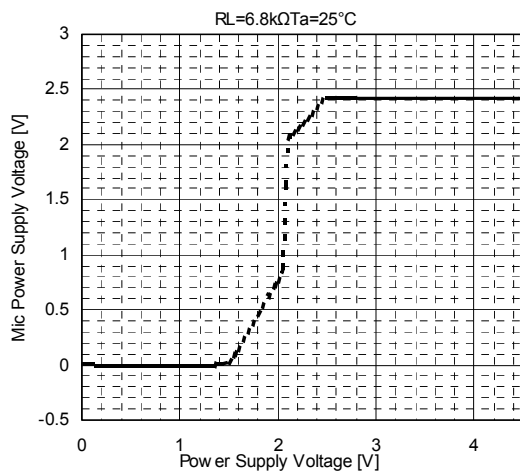

Mic Power Supply Voltage vs. Ambient Temperature

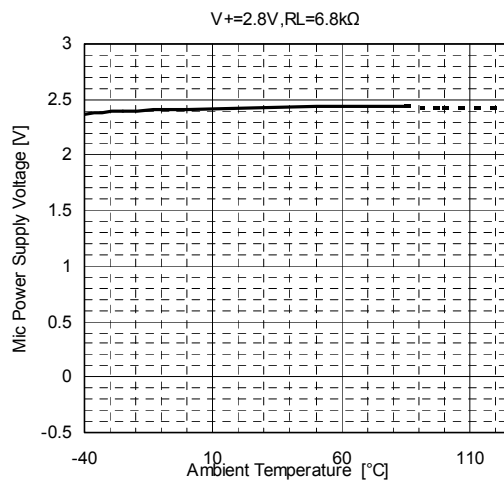

Voltage Gain vs. Frequency

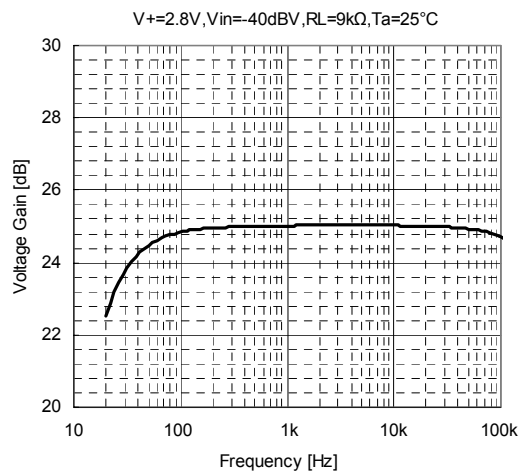

Voltage Gain vs. Ambient Temperature

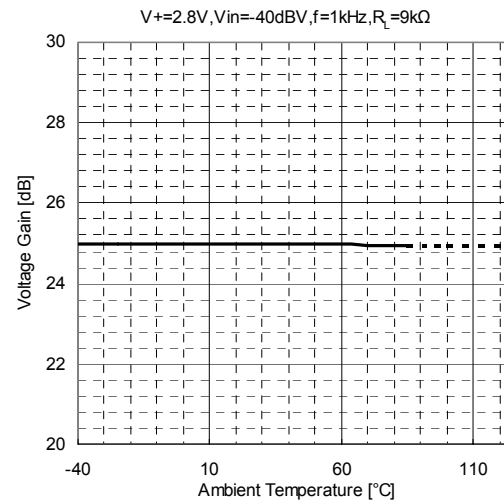

Voltage Gain vs. Standby Voltage (Ta)

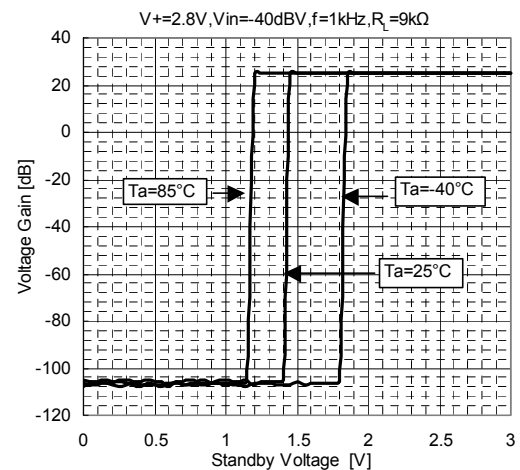

Output Noise vs. Ambient Temperature

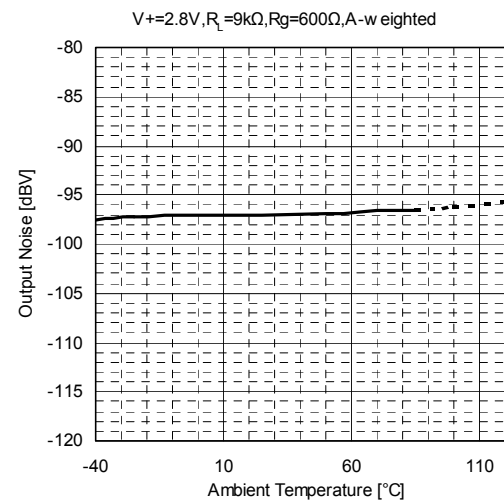

■ TYPICAL CHARACTERISTICS

Total Harmonic Distortion vs. Output Voltage (V+)

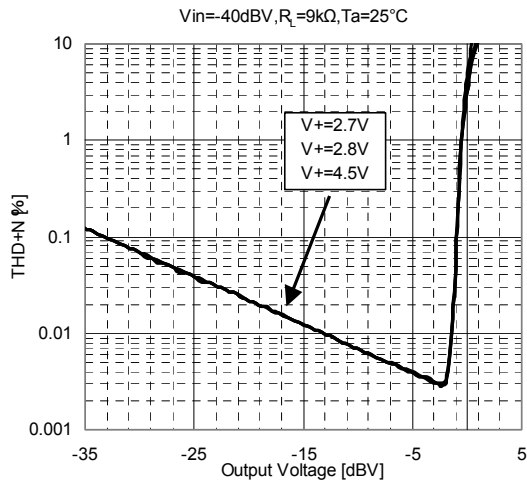

Total Harmonic Distortion vs. Output Voltage (Ta)

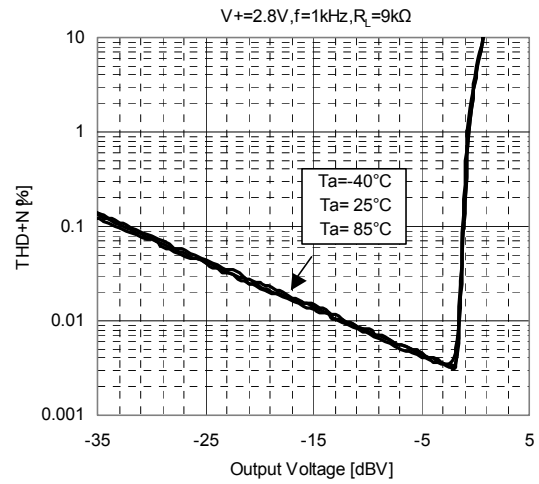

Total Harmonic Distortion vs. Output Voltage (f)

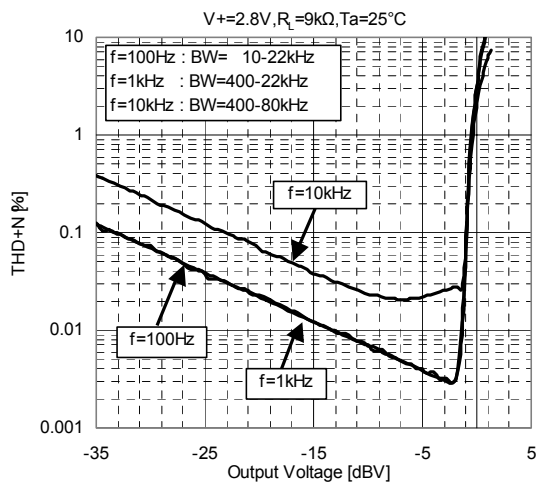

Power Supply Ripple Rejection vs. Frequency

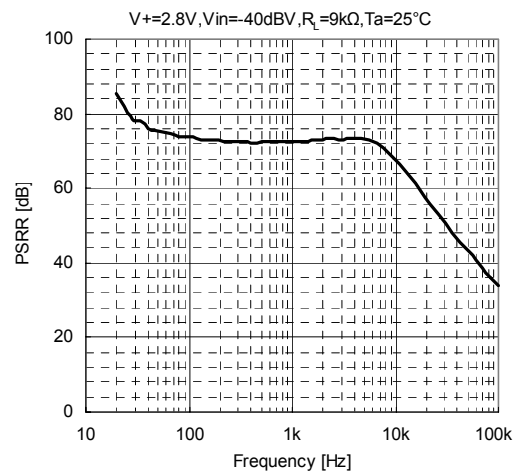

[CAUTION]

The specifications on this data book are only given for information, without any guarantee as regards either mistakes or omissions. The application circuits in this data book are described only to show representative usages of the product and not intended for the guarantee or permission of any right including the industrial rights.