



# EN5395QI 9A PowerSoC

## Step-Down DC-DC Switching Converter with Integrated Inductor

### DESCRIPTION

The EN5395QI is a Power System on a Chip (PowerSoC) DC-DC converter. It is specifically designed to meet the precise voltage and fast transient requirements of present and future high-performance, low-power processor, DSP, FPGA, ASIC, memory boards, and system level applications in distributed power architecture. Advanced circuit techniques, ultra-high switching frequency, and innovative, high-density, integrated circuit and proprietary inductor technology deliver high-quality, ultra-compact, non-isolated DC-DC conversion. Operating this converter requires as few as five external components that include small value input and output ceramic capacitors and a soft-start capacitor.

Intel Enpirion solution significantly helps in system design and productivity by offering greatly simplified board design, layout and manufacturing requirements. In addition, a reduction in the number of vendors required for the complete power solution helps to enable an overall system cost savings.

All Enpirion products are RoHS compliant and lead-free manufacturing environment compatible.

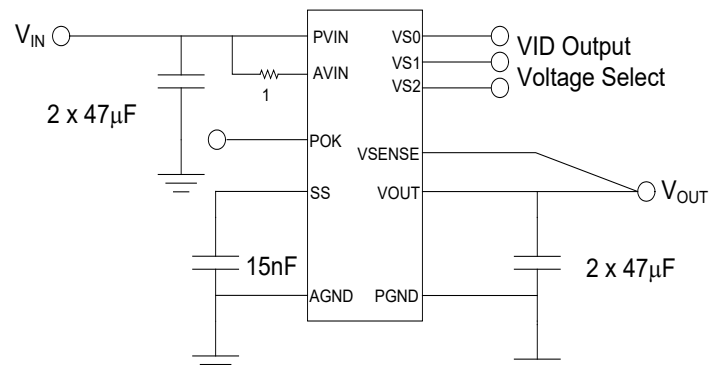
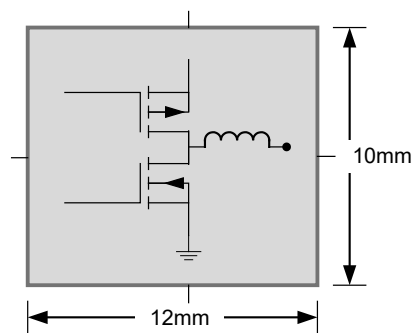

Figure 1: Simplified Applications Circuit

### NOT RECOMMENDED FOR NEW DESIGN

### FEATURES



- **Integrated Inductor Technology:** Integrated Inductor, MOSFETS, Controller in a 10 x 12 x 1.85mm package
- Low Part Count: only 5 MLC Capacitors.
- Up to 30W continuous output power.
- Low output impedance optimized for  $\leq 90$  nm
- Master/slave configuration for paralleling.
- 5MHz operating frequency.
- High efficiency, up to 93%.
- Wide input voltage range of 2.375V to 5.5V.
- 3-Pin VID output voltage select to choose one of 7 pre-programmed output voltages.
- Output Enable pin and Power OK signal.
- Programmable soft-start time.
- Adjustable over-current protection.
- Thermal shutdown, short circuit, over-voltage and under-voltage protection.
- RoHS compliant, MSL level 3, 260C reflow.

### APPLICATIONS

- Area constrained applications
- Noise sensitive applications
- Low voltage, distributed power architectures with 2.5V, 3.3V or 5V rails
- Computing
- Enterprise Storage
- Broadband, networking, LAN/WAN, optical
- DSL, STB, DVR, DTV, Industrial PC

## ORDERING INFORMATION

Part Number	Package Markings	T <sub>J</sub> Rating	Package Description
EN5395QI	EN5395QI	-40°C to +125°C	56-pin (10mm x 12mm x 1.85mm) QFN
EVB-EN5395QI	EN5395QI	QFN Evaluation Board	

**Packing and Marking Information:** <https://www.altera.com/support/quality-and-reliability/packing.html>

## PIN FUNCTIONS

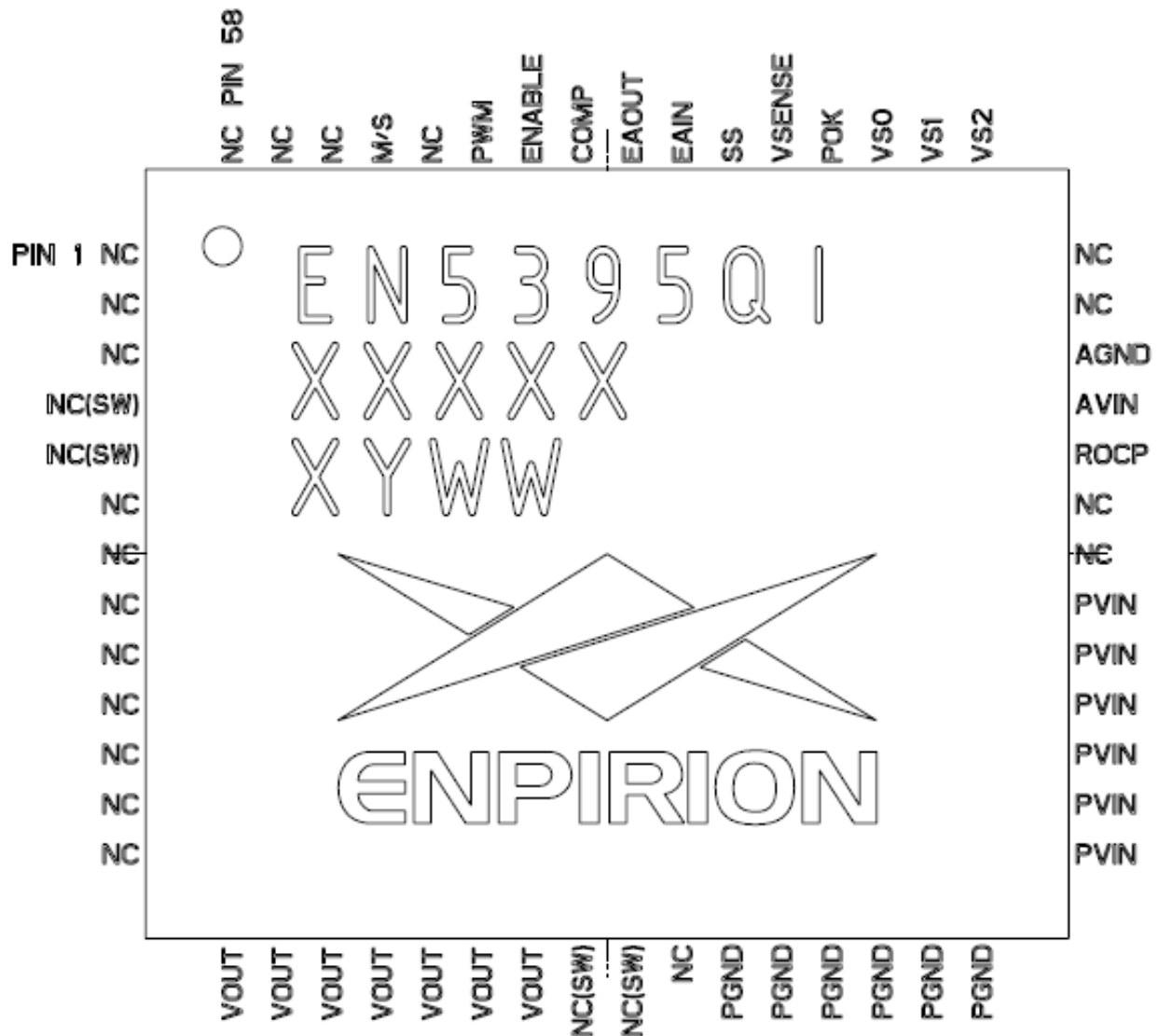

Figure 2: Pin Diagram (Top View)

**NOTE A:** NC pins are not to be electrically connected to each other or to any external signal, ground or voltage. However, they must be soldered to the PCB. Failure to follow this guideline may result in part malfunction or damage.

## PIN DESCRIPTIONS

PIN	NAME	TYPE	FUNCTION
1-3	NC	-	NO CONNECT – This pin should not be electrically connected to any external signal, voltage, or ground. This pin may be connected internally. However, this pin must be soldered to the PCB.
4-5	NC(SW)	-	NO CONNECT – These pins are internally connected to the common drain output of the internal MOSFETs. NC(SW) pins are not to be electrically connected to any external signal, ground, or voltage. However, they must be soldered to the PCB. Failure to follow this guideline may result in part malfunction or damage.
6-13	NC	-	NO CONNECT – This pin should not be electrically connected to any external signal, voltage, or ground. This pin may be connected internally. However, this pin must be soldered to the PCB.
14-20	VOUT	Power	Regulated converter output. Connect these pins to the load and place output capacitor from these pins the PGND pins 24-26.
21-22	NC(SW)	-	NO CONNECT – These pins are internally connected to the common drain output of the internal MOSFETs. NC(SW) pins are not to be electrically connected to any external signal, ground, or voltage. However, they must be soldered to the PCB. Failure to follow this guideline may result in part malfunction or damage.
23	NC	-	NO CONNECT – This pin should not be electrically connected to any external signal, voltage, or ground. This pin may be connected internally. However, this pin must be soldered to the PCB.
24-29	PGND	Power	Output power ground. Refer to layout guideline section.
30-35	PVIN	Power	Input power supply. Connect to input power supply. Decouple with input capacitor to PGND.
36-37	NC	-	NO CONNECT – This pin should not be electrically connected to any external signal, voltage, or ground. This pin may be connected internally. However, this pin must be soldered to the PCB.
38	ROCP	Analog	Optional Over Current Protection adjust pin. Place ROCP resistor between this pin and AGND (pin 40) to adjust the over current trip point.
39	AVIN	Power	Analog voltage input for the controller circuits. Connect this pin to the input power supply.
40	AGND	Power	Analog ground for the controller circuits.
41-42	NC	-	NO CONNECT – This pin should not be electrically connected to any external signal, voltage, or ground. This pin may be connected internally. However, this pin must be soldered to the PCB.
43	VS2	Analog	Voltage select line 2 input. See Table 1.
44	VS1	Analog	Voltage select line 1 input. See Table 1.
45	VS0	Analog	Voltage select line 0 input. See Table 1.
46	POK	Digital	Power OK is an open drain transistor for power system state indication. POK is a logic high when VOUT is with -10% to +20% of VOUT nominal.

PIN	NAME	TYPE	FUNCTION
47	VSENSE	Analog	Remote voltage sense input. Connect this pin to the load voltage at the point to be regulated.
48	SS	Analog	Soft-Start node. The soft-start capacitor is connected between this pin and AGND. The value of this capacitor determines the startup timing.
49	EAIN	Analog	Optional Error Amplifier input. Allows for customization of the control loop.
50	EAOUT	Analog	Optional Error Amplifier output. Allows for customization of the control loop.
51	COMP	Analog	Output of the buffer leading to the error amplifier. Used for external modifications of the compensation network.
52	ENABLE	Analog	Input Enable. Applying a logic high, enables the output and initiates a soft-start. Applying a logic low disables the output.
53	PMW	Analog	PWM input/output. Used for optional master/slave configuration. When M/S pin is asserted "low", PWM will output the gate-drive PWM waveform. When the M/S pin is asserted "high", the PWM pin is configured as an input for PWM signal from the "master" device. PWM pin can drive up to 3 slave devices.
54	NC	-	NO CONNECT – This pin should not be electrically connected to any external signal, voltage, or ground. This pin may be connected internally. However, this pin must be soldered to the PCB.
55	M/S	Analog	Optional Master/Slave select pin. Asserting pin "low" places device in Master Mode for current sharing. PWM pin (53) will output PWM drive signal. Asserting pin "high" will place the device in Slave Mode. PWM pin (53) will be configured to input (receive) PWM drive signal from "Master" device.
56-58	NC	-	NO CONNECT – Do not electrically connect these pins to each other or to PCB. CAUTION! May be internally connected.

## ABSOLUTE MAXIMUM RATINGS

**CAUTION:** Absolute Maximum ratings are stress ratings only. Functional operation beyond the recommended operating conditions is not implied. Stress beyond the absolute maximum ratings may impair device life. Exposure to absolute maximum rated conditions for extended periods may affect device reliability.

### Absolute Maximum Pin Ratings

PARAMETER	SYMBOL	MIN	MAX	UNITS
PVIN		-0.5	7.0	V
ENABLE, VSENSE, VS0-VS2, M/S		-0.5	V <sub>IN</sub>	V
EAIN, EAOUT, COMP		-0.5	2.5	V
SS, PWM		-0.5	3.0	V
POK		-0.5	V <sub>IN</sub> +0.3	V

### Absolute Maximum Thermal Ratings

PARAMETER	CONDITION	MIN	MAX	UNITS
Maximum Operating Junction Temperature			+150	°C
Storage Temperature Range		-65	+150	°C
Reflow Peak Body Temperature	(10 Sec) MSL3 JEDEC J-STD-020A		+260	°C

### Absolute Maximum ESD Ratings

PARAMETER	CONDITION	MIN	MAX	UNITS
HBM (Human Body Model)		±2000		V
CDM (Charged Device Model)		±500		V

## RECOMMENDED OPERATING CONDITIONS

PARAMETER	SYMBOL	MIN	MAX	UNITS
Input Voltage Range	V <sub>IN</sub>	2.375	5.5	V
Output Voltage Range	V <sub>OUT</sub>	0.75	V <sub>IN</sub> - V <sub>DO</sub> <sup>(1)</sup>	V
Output Current Range	I <sub>OUT</sub>	0	9 <sup>(2)</sup>	A
Operating Ambient Temperature Range	T <sub>A</sub>	-40	+85	°C
Operating Junction Temperature	T <sub>J</sub>	-40	+125	°C

## THERMAL CHARACTERISTICS

PARAMETER	SYMBOL	TYPICAL	UNITS
Thermal Overload Trip Point	$T_{SD}$	150	°C
Thermal Overload Trip Point Hysteresis	$T_{SDHYS}$	20	°C
Thermal Resistance: Junction to Ambient (0 LFM) <sup>(3)</sup>	$\theta_{JA}$	18	°C/W
Thermal Resistance: Junction to Case (0 LFM)	$\theta_{JC}$	1.5	°C/W

(1)  $V_{DO}$  (dropout voltage) is defined as ( $I_{LOAD} \times \text{Dropout Resistance}$ ). Please refer to Electrical Characteristics Table.

(2) Reference figures 5 and 6 for the Output Current Derating Curves.

(3) Based on four layer board and proper thermal design in line with JEDEC EIJ/JESD 51 standards.

## ELECTRICAL CHARACTERISTICS

NOTE:  $V_{IN} = 5.5V$ , Minimum and Maximum values are over operating ambient temperature range unless otherwise noted. Typical values are at  $T_A = 25^\circ C$ .

PARAMETER	SYMBOL	TEST CONDITIONS	MIN	TYP	MAX	UNITS
$V_{OUT}$ Initial Accuracy	$\Delta V_{OUT\_INIT}$	$T_A = 25^\circ C$ , $2.375V \leq V_{IN} \leq 5.5V$ $I_{LOAD} = 1A$ ; $T_A = 25^\circ C$ VID Output Voltage Setting (V): 1.2, 1.25, 1.5, 1.8, 2.5, 3.3 0.8	-2 -3		+2 +3	%
Overall $V_{OUT}$ Accuracy (Line, Load, and Temperature combined)	$\Delta V_{OUT\_ALL}$	$2.4V \leq V_{IN} \leq 5.5V$ $-40^\circ C \leq T_A \leq +85^\circ C$ $0A \leq I_{LOAD} \leq 9A$ VID Output Voltage Setting (V): 1.2, 1.25, 1.5, 1.8, 2.5, 3.3 0.8	-3 -4		+3 +4	%
Transient Response Peak Deviation	$\Delta V_{OUT}$	( $I_{OUT} = 0\%$ to $100\%$ or $100\%$ to $0\%$ or rated load) $V_{IN} = 5V$ , $1.2V \leq V_{OUT} \leq 3.3V$ $C_{OUT} = 2 \times 47 \mu F$		5		%
Under Voltage Lock out threshold	$V_{UVLO}$	$V_{IN}$ Increasing $V_{IN}$ Decreasing		2.2 2.1		V

PARAMETER	SYMBOL	TEST CONDITIONS	MIN	TYP	MAX	UNITS
Switching Frequency	$F_{\text{SWITCH}}$			5		MHz
Continuous Output Current	$I_{\text{OUT}}$	$2.375\text{V} \leq V_{\text{IN}} \leq 5.5\text{V}$ $0.603 < V_{\text{OUT}} < V_{\text{IN}} - 0.5$ $T_{\text{A}} = -40^{\circ}\text{C to } +60^{\circ}\text{C}$ <i>NOTE: reference figures 5 and 6 for the output current derating curves</i>	9			A
Current Limit Threshold	$I_{\text{OCP\_TH}}$			11		A
Shut-Down Supply Current	$I_{\text{S}}$	ENABLE=0V		50		$\mu\text{A}$
Disable Threshold	$V_{\text{DISABLE}}$	Max voltage to ensure the converter is disabled			0.8	V
Enable Threshold	$V_{\text{ENABLE}}$	$2.375\text{V} \leq V_{\text{IN}} \leq 5.5\text{V}$ $5.5\text{V} < V_{\text{IN}}$	1.8 2.0			V
Enable Pin Current	$I_{\text{EN}}$	$V_{\text{IN}} = 5.5\text{V}$		50		$\mu\text{A}$
VS0-VS1, Enable Voltage Threshold	$V_{\text{TH}}$	Pin = Low Pin = High	0.0 1.4		0.4 $V_{\text{IN}}$	
VS0-VS2 Pin Input Current	$I_{\text{VSX}}$	$V_{\text{SX}} = \text{GND}$ $V_{\text{SX}} = V_{\text{IN}}$ $V_{\text{SX}} = \text{Open}$		50 0 0		$\mu\text{A}$
POK threshold High		Percentage of $V_{\text{OUT}}$ Nominal		120		%
POK threshold Low		Percentage of $V_{\text{OUT}}$ Nominal		90		%
POK Low Voltage		$I_{\text{POK}} = 4\text{mA}$ (Max Sink Current)			0.4	V
POK High Voltage					$V_{\text{IN}}$	V
Dropout Resistance				50		$\text{m}\Omega$
Current Balance	$\Delta I_{\text{OUT}}$	With 2 – 4 converters in parallel, the difference between any 2 parts. $\Delta V_{\text{IN}} < 50\text{mV}$ ; $R_{\text{TRACE}} < 10\text{m}\Omega$ .		+/-10		%

## TYPICAL PERFORMANCE CURVES

Circuit of Figure 1,  $V_{IN} = 5\text{ V}$ ,  $V_{OUT} = 1.2\text{ V}$  and  $T_A = 25^\circ\text{C}$ , unless otherwise noted.

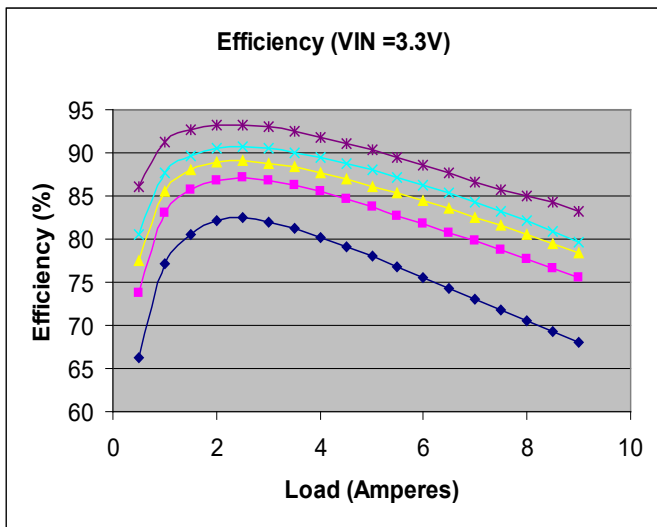

Top to Bottom:  $V_{OUT} = 2.5\text{ V}$ ,  $1.8\text{ V}$ ,  $1.5\text{ V}$ ,  $1.2\text{ V}$ ,  $0.8\text{ V}$

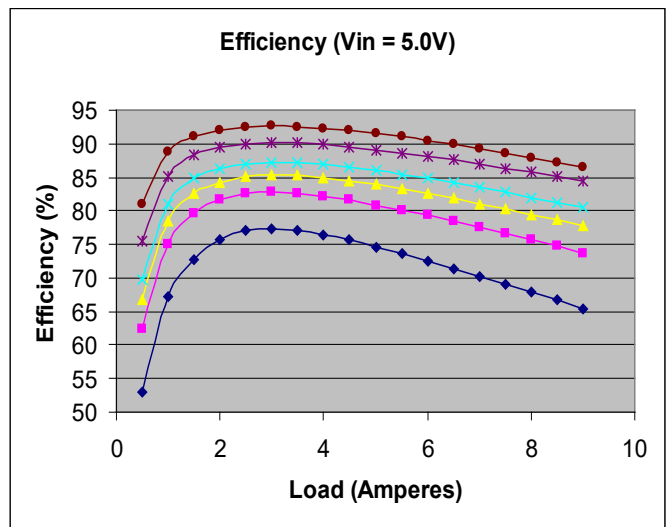

Top to Bottom:  $V_{OUT} = 3.3\text{ V}$ ,  $2.5\text{ V}$ ,  $1.8\text{ V}$ ,  $1.5\text{ V}$ ,  $1.2\text{ V}$ ,  $0.8\text{ V}$



## TYPICAL PERFORMANCE CHARACTERISTICS

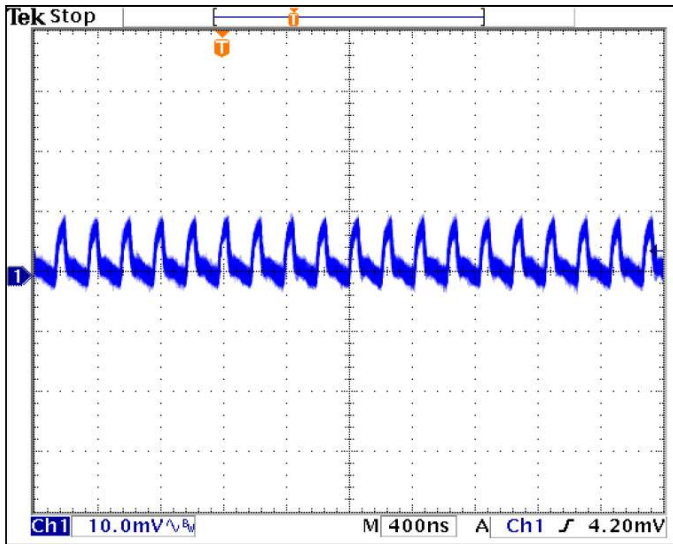

Ripple Voltage,  $5.5V_{IN}/1.2V_{OUT}$ ,  $I_{OUT}=9A$ ,  
 $C_{OUT} = 5 \times 22\mu F$

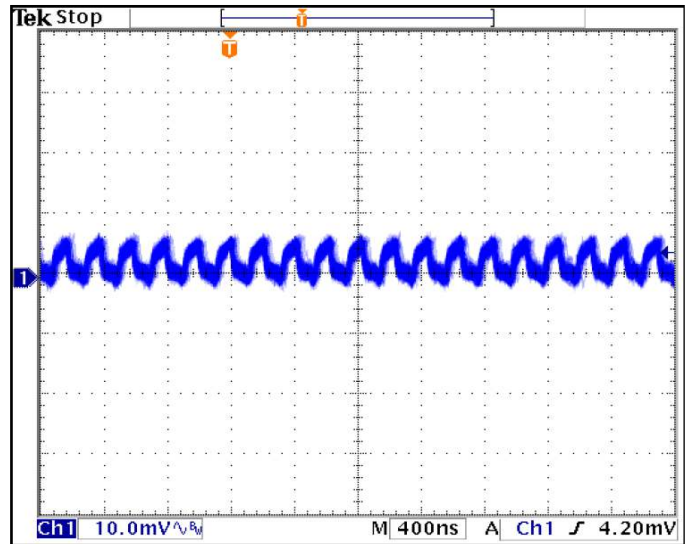

Ripple Voltage,  $3.3V_{IN}/1.2V_{OUT}$ ,  $I_{OUT}=9A$ ,  
 $C_{OUT} = 5 \times 22\mu F$

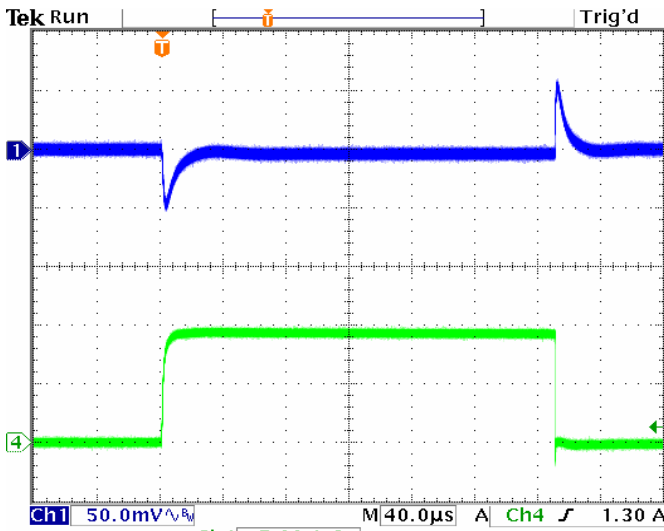

Transient Response:  $5V_{IN}/1.2V_{OUT}$ , 0-9A,  $7A/\mu S$ ,  
 $C_{OUT} = 5 \times 22\mu F$

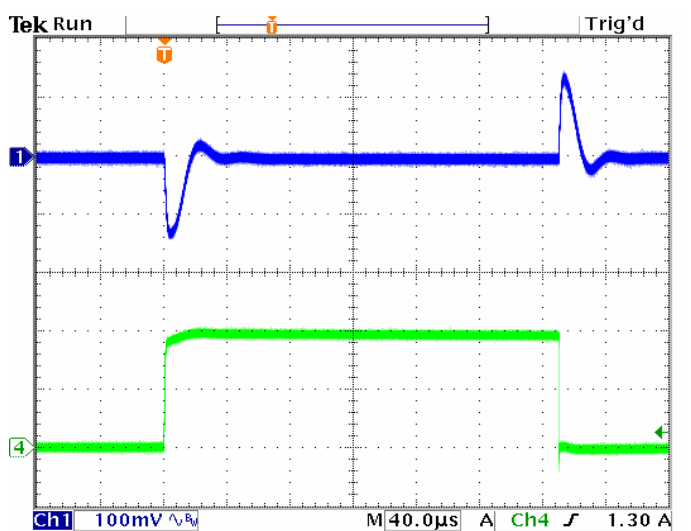

Transient Response:  $5V_{IN}/3.3V_{OUT}$ , 0-9A,  $7A/\mu S$ ,  
 $C_{OUT} = 5 \times 22\mu F$

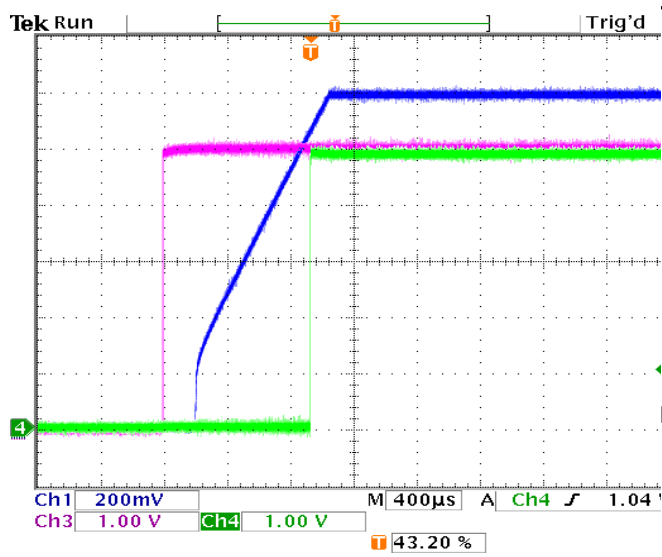

Start up waveforms  $V_{IN}=5.0V$ ,  $V_{OUT}=1.2V$ ,  $C_{SS}=15nF$

Ch 1 =  $V_{OUT}$ , Ch 3 = ENABLE, Ch 4 = POK.

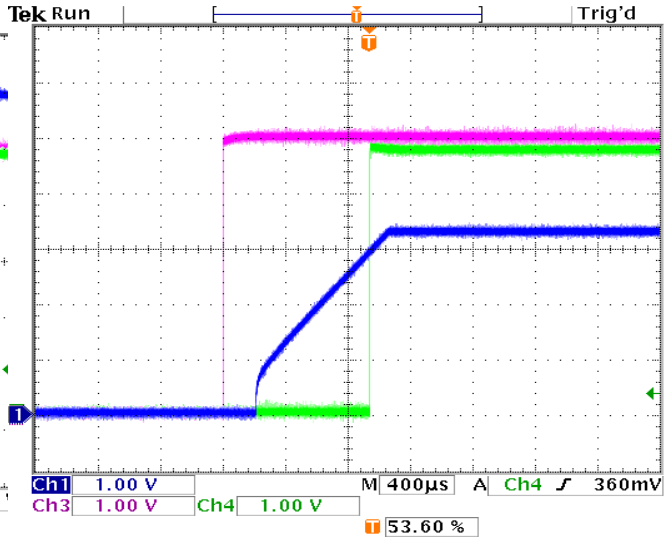

Start up waveforms  $V_{IN}=5.0V$ ,  $V_{OUT}=3.3V$ ,  $C_{SS}=15nF$

Ch 1 =  $V_{OUT}$ , Ch 3 = ENABLE, Ch 4 = POK.

## FUNCTIONAL BLOCK DIAGRAM

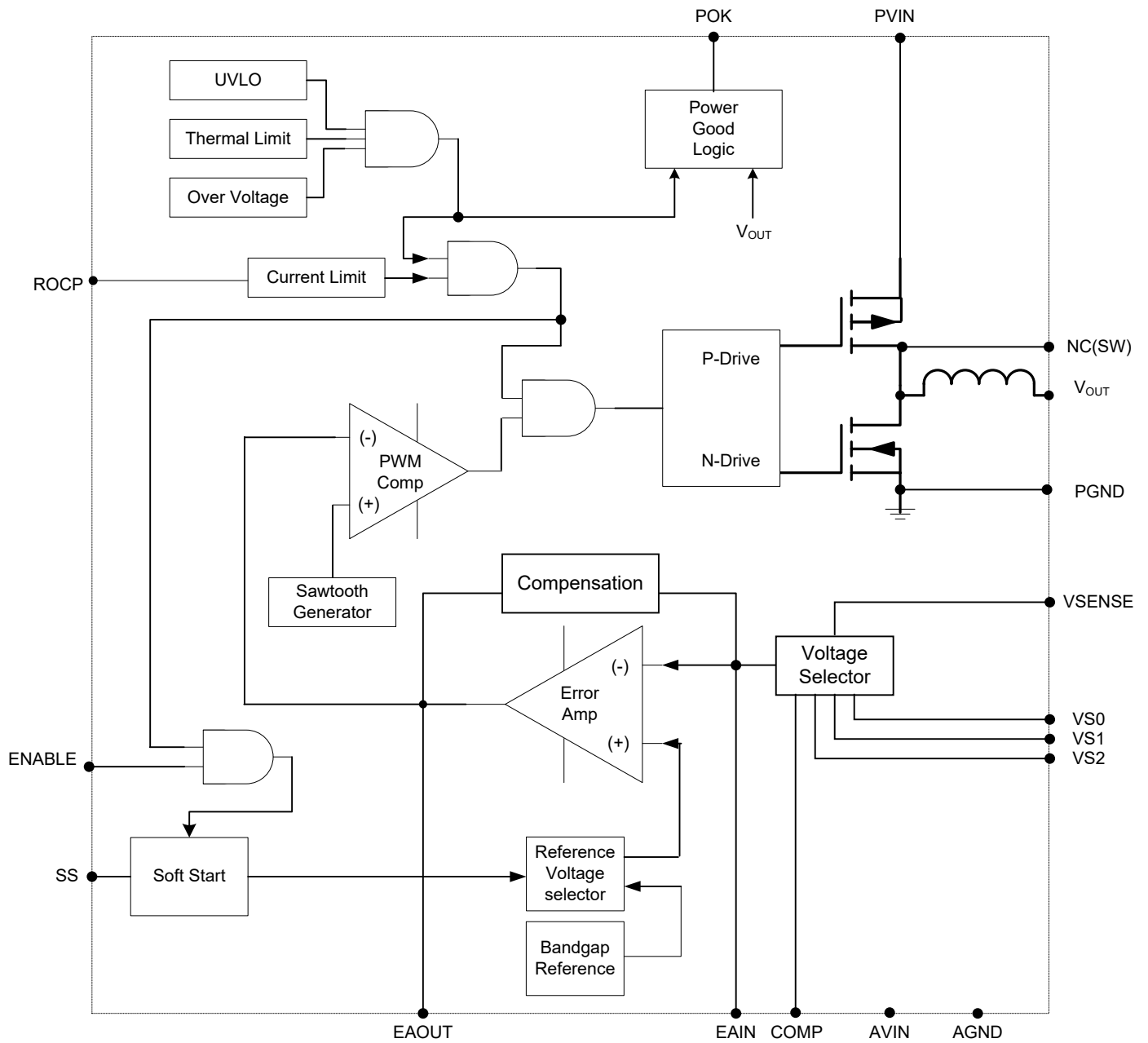

Figure 3: Functional Block Diagram

## FUNCTIONAL DESCRIPTION

### Synchronous DC-DC Step-Down PowerSoC

The EN5395QI is a synchronous, pin programmable power supply with integrated power MOSFET switches and integrated inductor. The nominal input voltage range is 2.375-5.5V. The output can be set to common pre-set voltages by connecting appropriate combinations of 3 voltage selection pins to ground. The feedback control loop is a type III voltage-mode and the part uses a low-noise PWM topology. Up to 9A of output current can be drawn from this converter. The 5MHz operating frequency enables the use of small-size output capacitors.

The power supply has the following protection features:

- Programmable over-current protection (to protect the IC from excessive load current)
- Thermal shutdown with hysteresis.
- Over-voltage protection
- Under-voltage lockout circuit to disable the converter output when the input voltage is less than approximately 2.2V

Additional features include:

- Soft-start circuit, limiting the in-rush current when the converter is powered up.
- Power good circuit indicating whether the output voltage is within 90%-120% of the programmed voltage.

### Output Voltage Programming

The EN5395QI output voltage is programmed using a 3-pin voltage-ID or VID selector. Three binary VID pins allow the user to choose one of seven pre-set voltages. Refer to table 1 for the proper VID pin settings to program  $V_{OUT}$ .

The voltage select pins, VS0, VS1, and VS2, are pulled-up internally and so will default to a logic high, or "1", if left "open". Connecting the voltage select pin to ground will result in a logic "0".

**Table 1: Recommended Input Capacitors**

VS2*	VS1*	VS0*	Output Voltage
0	0	0	3.3V
0	0	1	2.5V
0	1	0	1.8V
0	1	1	1.5V
1	0	0	1.25V
1	0	1	1.2V
1	1	0	0.8V
1	1	1	Reserved

## Input Capacitor Selection

The EN5395QI requires between 40–80 $\mu$ F of input capacitance. Low ESR ceramic capacitors are required with X5R or X7R rated dielectric formulation. Y5V or equivalent dielectric formulations must not be used as these lose capacitance with frequency, temperature and bias voltage.

In some applications, lower value capacitors are needed in parallel with the larger, capacitors in order to provide high frequency decoupling.

**Table 2. Recommended input capacitors**

Description	MFG	P/N
22 $\mu$ F, 10V, X7R, 1210	Murata	GRM32ER71A226KE20L
	Taiyo Yuden	LMK325B7226KM-T
47 $\mu$ F, 10V, X5R, 1210	Murata	GRM32ER61A476KE20L
	Taiyo Yuden	LMK325BJ476KM-T

## Output Capacitor Selection

The EN5395QI has been optimized for use with approximately 100 $\mu$ F of output capacitance. Low ESR ceramic capacitors are required with X5R or X7R rated dielectric formulation. Y5V or equivalent dielectric formulations must not be used as these lose capacitance with frequency, temperature and bias voltage.

**Table 3. Recommended output capacitors**

Description	MFG	P/N
10 $\mu$ F, 10V, X7R, 1206	Murata	GRM31CR71A106KA01L
	Taiyo Yuden	LMK316B7106KL-T
22 $\mu$ F, 6.3V, X5R, 1206	Murata	GRM31CR60J226KE19L
	Taiyo Yuden	LMK316BJ226KL-T
47 $\mu$ F, 6.3V, X5R, 1206	Murata	GRM31CR60J476ME19L
	Taiyo Yuden	JMK316BJ476ML-T

Output ripple voltage is determined by the aggregate output capacitor impedance. Output impedance, denoted as Z, is comprised of effective series resistance, ESR, and effective series inductance, ESL:

$$Z = \text{ESR} + \text{ESL}.$$

Placing output capacitors in parallel reduces the impedance and will hence result in lower ripple voltage.

$$\frac{1}{Z_{Total}} = \frac{1}{Z_1} + \frac{1}{Z_2} + \dots + \frac{1}{Z_n}$$

Typical ripple versus capacitor arrangement is given below (5.5V<sub>IN</sub>/1.2V<sub>OUT</sub>):

**Table 4. Typical Output Ripple**

Output Capacitor Configuration	Typical Output Ripple (mVp-p) (as measured on EN5395QI Evaluation Board)
2 x 47µF	20
5 x 22 µF	12

## Enable Operation

The ENABLE pin provides a means to shut down the device, or enable normal operation. A logic low will disable the converter and cause it to shut down. A logic high will enable the converter into normal operation. When the ENABLE pin is asserted high, the device will undergo a normal soft start.

## Soft-Start Operation

Soft start is a method to reduce in-rush current when the device is enabled. The output voltage is ramped up slowly upon start-up. The output rise time is controlled by choice of a soft-start

capacitor, which is placed between the SS pin (pin 48) and the AGND pin (pin 40).

Rise Time:  $T_R = C_{SS} * 80K\Omega$

During start-up of the converter, the reference voltage to the error amplifier is gradually increased to its final level by an internal current source of typically 10µA. Typical soft-start rise time is 1mS to 3mS. Typical SS capacitor values are in the range of 15nF to 30 nF.

## Startup into Pre-Bias

The EN5395QI supports startup into a pre-biased output of up to 1.5V. The output of the EN5395QI can be pre-biased with a voltage up to 1.5V when it is first enabled.

## POK Operation

The POK signal is an open drain signal from the converter indicating the output voltage is within the specified range. The POK signal will be a logic high when the output voltage is within 90% - 120% of the programmed output voltage. If the output voltage goes outside of this range, the POK signal will be a logic low until the output voltage has returned to within this range. In the event of an over-voltage condition the POK signal will go low and will remain in this condition until the output voltage has dropped to 95% of the programmed output voltage before returning to the high state.

The internal POK FET is designed to tolerate up to 4mA. The pull-up resistor value should be chosen to limit the current from exceeding this value when POK is logic low.

## Over-Current Protection

When an over current condition occurs,  $V_{OUT}$  is pulled low. This condition is maintained for a period of 1.2 ms and then a normal soft start cycle is initiated. If the over current condition still persists, this cycle will repeat.

The OCP trip point is nominally set to 150% of maximum rated load. It is possible to increase the OCP trip point to 200% of the maximum rated load by connecting a 5k $\Omega$  resistor between the ROCP pin (pin 38) and AGND (pin 40). This option is intended for startup into capacitive loads such as certain FPGAs and ASICs.

## Over-Voltage Protection

When the output voltage exceeds 120% of the programmed output voltage, the PWM operation stops, the lower N-MOSFET is turned on and the

POK signal goes low. When the output voltage drops below 95% of the programmed output voltage, normal PWM operation resumes and POK returns to its high state.

## Thermal Overload Protection

Thermal shutdown will disable operation once the Junction temperature exceeds approximately 150°C. Once the junction temperature drops by approx. 20°C, the converter will re-start with a normal soft-start.

## Input Under-voltage Lock-out

Circuitry is provided to ensure that when the input voltage is below the specified voltage range, the converter will not start-up. Circuits for hysteresis, input de-glitch and output leading edge blanking are included to ensure high noise immunity and prevent false tripping.

## Compensation

The EN5395QI is internally compensated through the use of a type 3 compensation network and is optimized for use with about 100 $\mu$ F of output capacitance and will provide excellent loop bandwidth and transient performance for most applications. (See the section on Capacitor Selection for details on recommended capacitor types.) Voltage mode operation provides high noise immunity at light load.

In some cases modifications to the compensation may be required. The EN5395QI provides access to the internal compensation network to allow for customization. For more information, contact Power Applications support.

## Parallel Device Operation

In order to power a load that is higher than the rated 9A of the EN5395, from 2 to 4 devices can be placed in parallel for providing a single load with up to 36A of output current.

Paralleling more than 1 device is accomplished by selecting a master device and tying that M/S pin to AGND. All slave devices should have their M/S pin tied to AVIN. The PWM pin from the master device is connected to all slave device PWM pins. The PWM signal is a 5 MHz drive signal and must be routed appropriately.

1. All master and slave devices should have identical placement and values of input, output and soft-start capacitors.
2. All master and slave devices should have their ENABLE pins tied together and should be operated simultaneously with a fast rising edge of 10  $\mu$ Sec or less, to ensure that devices start up at the same time. Startup imbalance could lead to OCP condition on first device to startup.
3. The maximum board trace resistance between any 2 devices VOUT pins should be less than 10m $\Omega$ .
4. The maximum difference of PVIN between any 2 devices should be less than 50mV.

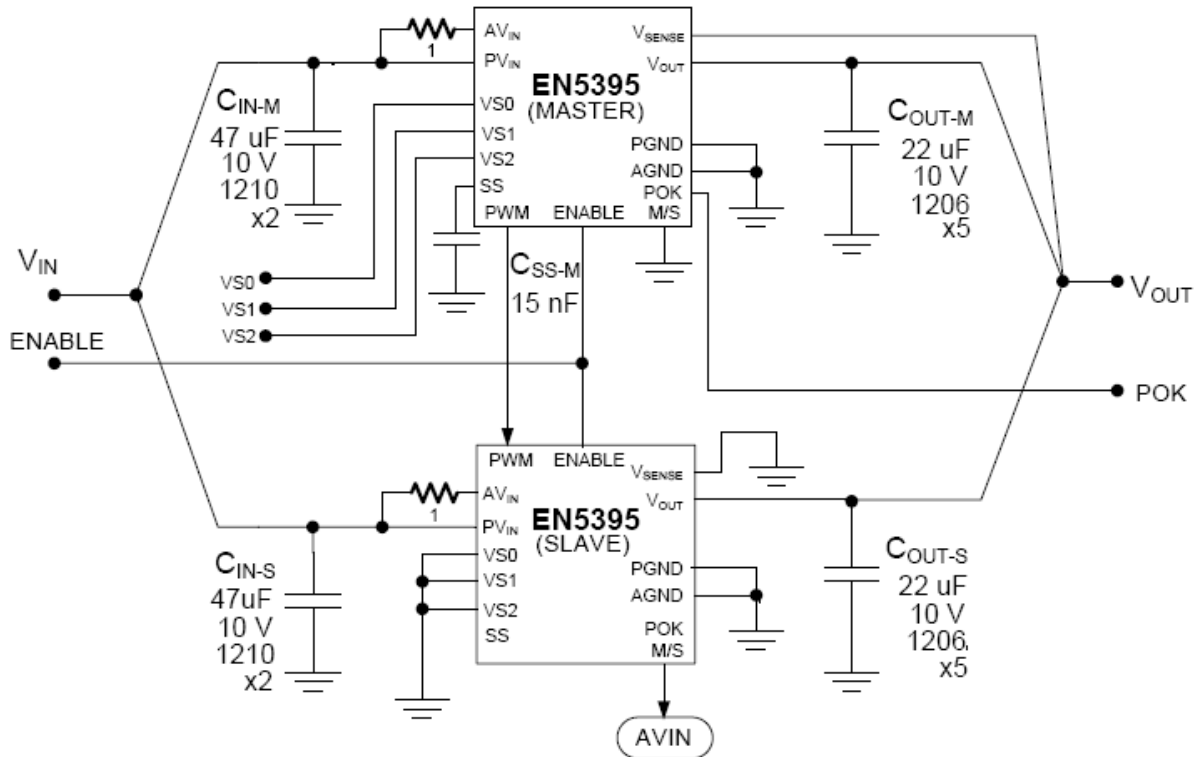

Figure 4: Paralleling of two devices

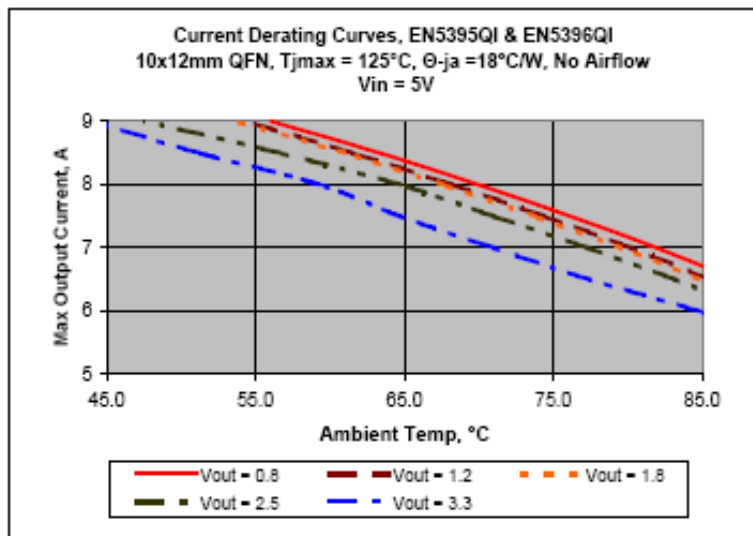

Figure 5: Output Current Derating Curve,  $V_{IN} = 5.0\text{V}$



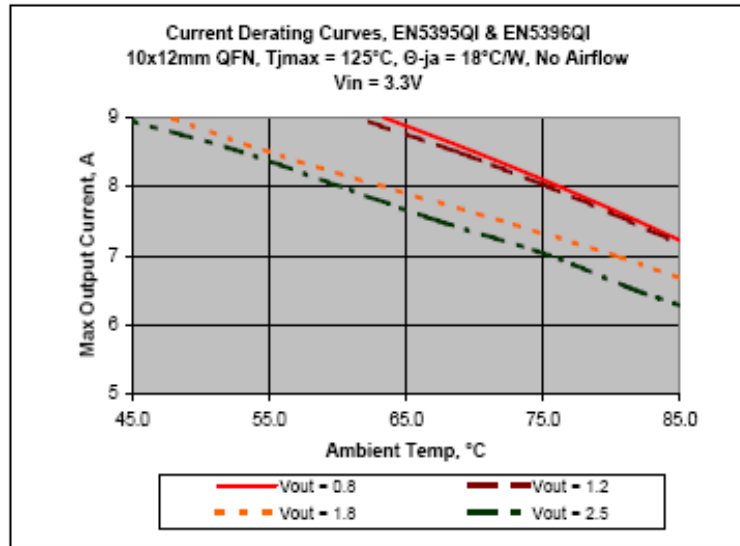

Figure 6: Output Current Derating Curve, VIN = 3.3V

## LAYOUT RECOMMENDATIONS

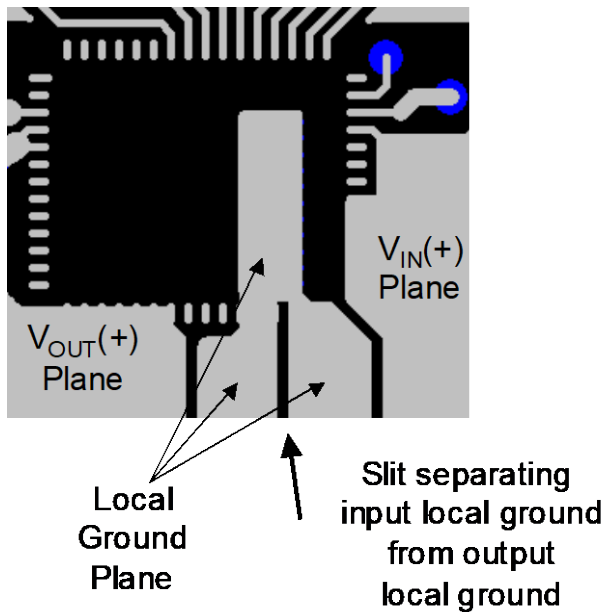

Figure 7. Layout of power and ground planes

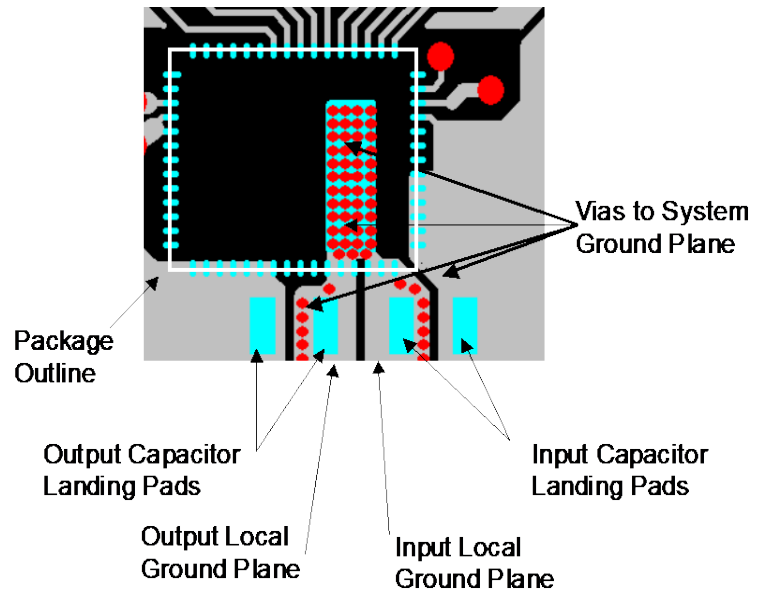

Figure 8. Use of vias connecting local and system ground.

**Recommendation 1:** Input and output capacitors should be placed as close to the EN5395QI package as possible to reduce EMI from input and output loop currents. This reduces the physical area of the Input and Output AC current loops.

**Recommendation 2:** Place a slit in the input/output capacitor ground plane just beyond the common connection point of the GND pins of the device as shown in figure 7.

**Recommendation 3:** Multiple small (0.25mm) vias should be used to connect ground terminal of the Input capacitor and the output capacitor to the system ground plane as shown in figure 8.

**Recommendation 4:** The large thermal pad underneath the component must be connected to the system ground plane through as many vias as possible. The diameter of the vias should be less than 0.3mm. This provides the quiet, or analog ground for the converter and also provides the path for heat dissipation from the converter. A later section of this note makes a recommendation on the PCB footprint.

**Recommendation 5:** The system ground plane referred to in recommendations 3 and 4 should be the first layer immediately below the surface layer. This ground plane should be continuous and un-interrupted below the converter and the input and output capacitors that carry large AC currents.

**Recommendation 6:** As with any switch-mode DC-DC converter, do not run sensitive signal or control lines underneath the converter package.

## DESIGN CONSIDERATIONS FOR LEAD-FRAME BASED MODULES

### Exposed Metal on Bottom of Package

Lead frame offers many advantages in thermal performance, in reduced electrical lead resistance, and in overall foot print. However, they do require some special considerations.

In the assembly process lead frame construction requires that, for mechanical support, some of the lead-frame cantilevers be exposed at the point where wire-bond or internal passives are attached. This results in several small pads being exposed on the bottom of the package.

Only the large thermal pad and the perimeter pads are to be mechanically or electrically connected to the PCB. The PCB top layer under the EN5395QI should be clear of any metal except for the large thermal pad. The “grayed-out” area in Figure 9 represents the area that should be clear of any metal (traces, vias, or planes), on the top layer of the PCB.

Figure 9 demonstrates the recommended PCB footprint for the EN5395QI. Figure 10 shows the shape and location of the exposed metal pads as well as the mechanical dimension of the large thermal pad and the pins.

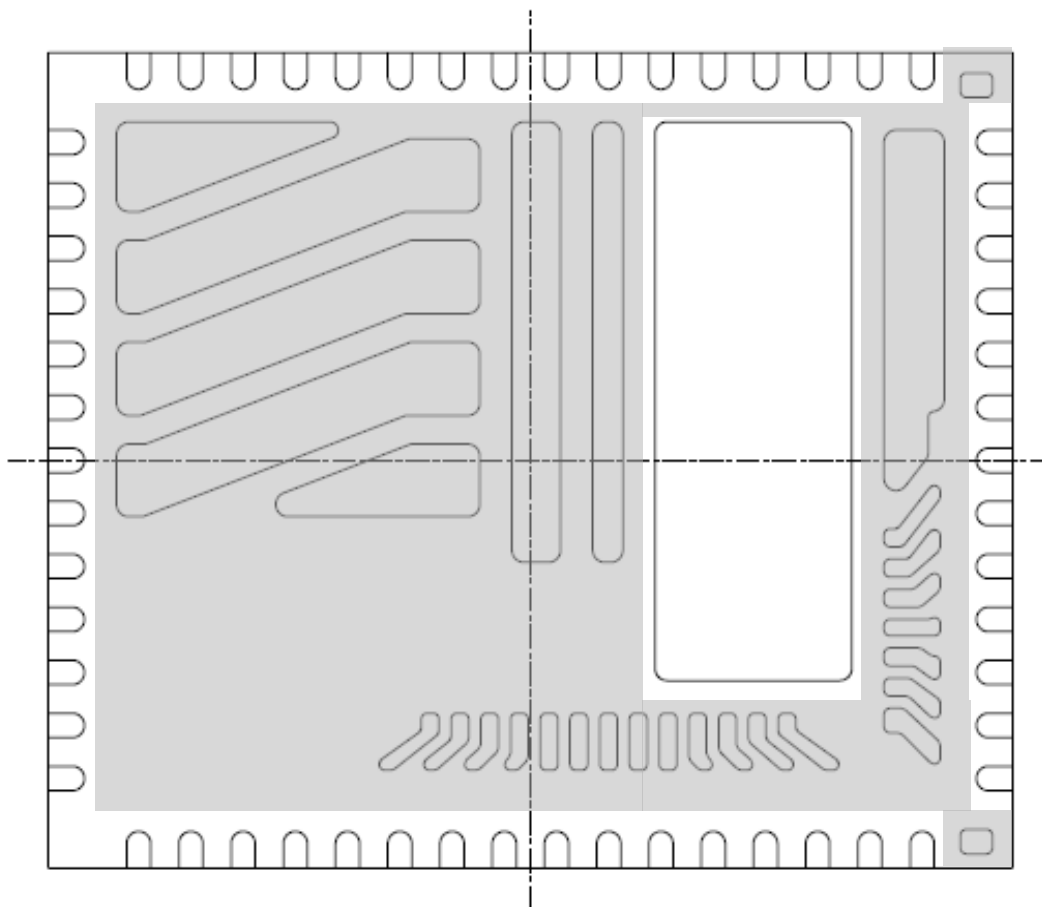

**Figure 9. Lead-Frame exposed metal. Grey area highlights exposed metal that is not to be mechanically or electrically connected to the PCB**

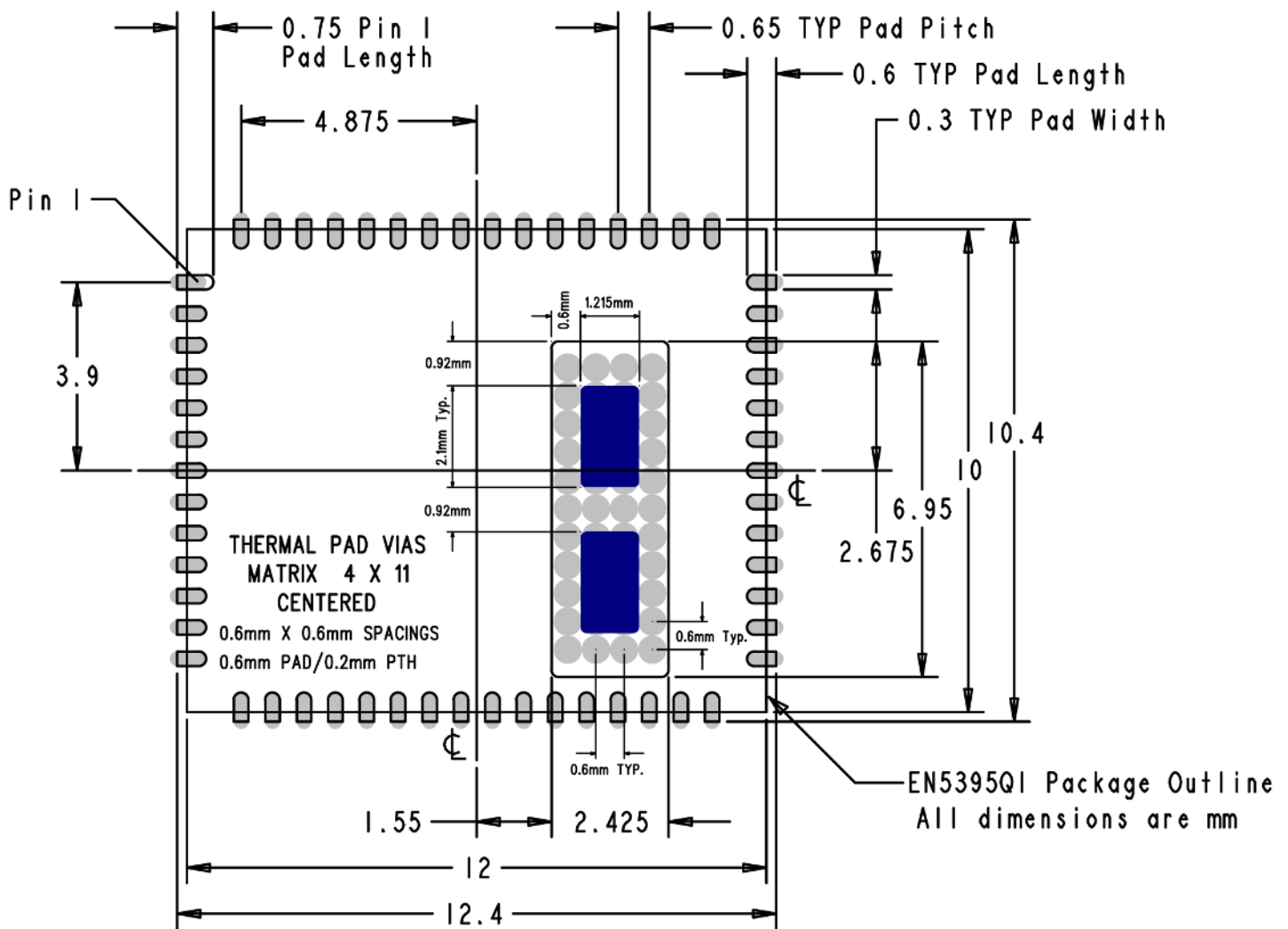

Figure 10. EN5395QI PCB Footprint (Top View)

The solder stencil aperture for the thermal pad is shown in blue and is based on Enpirion power product manufacturing specifications

## PACKAGE DIMENSIONS

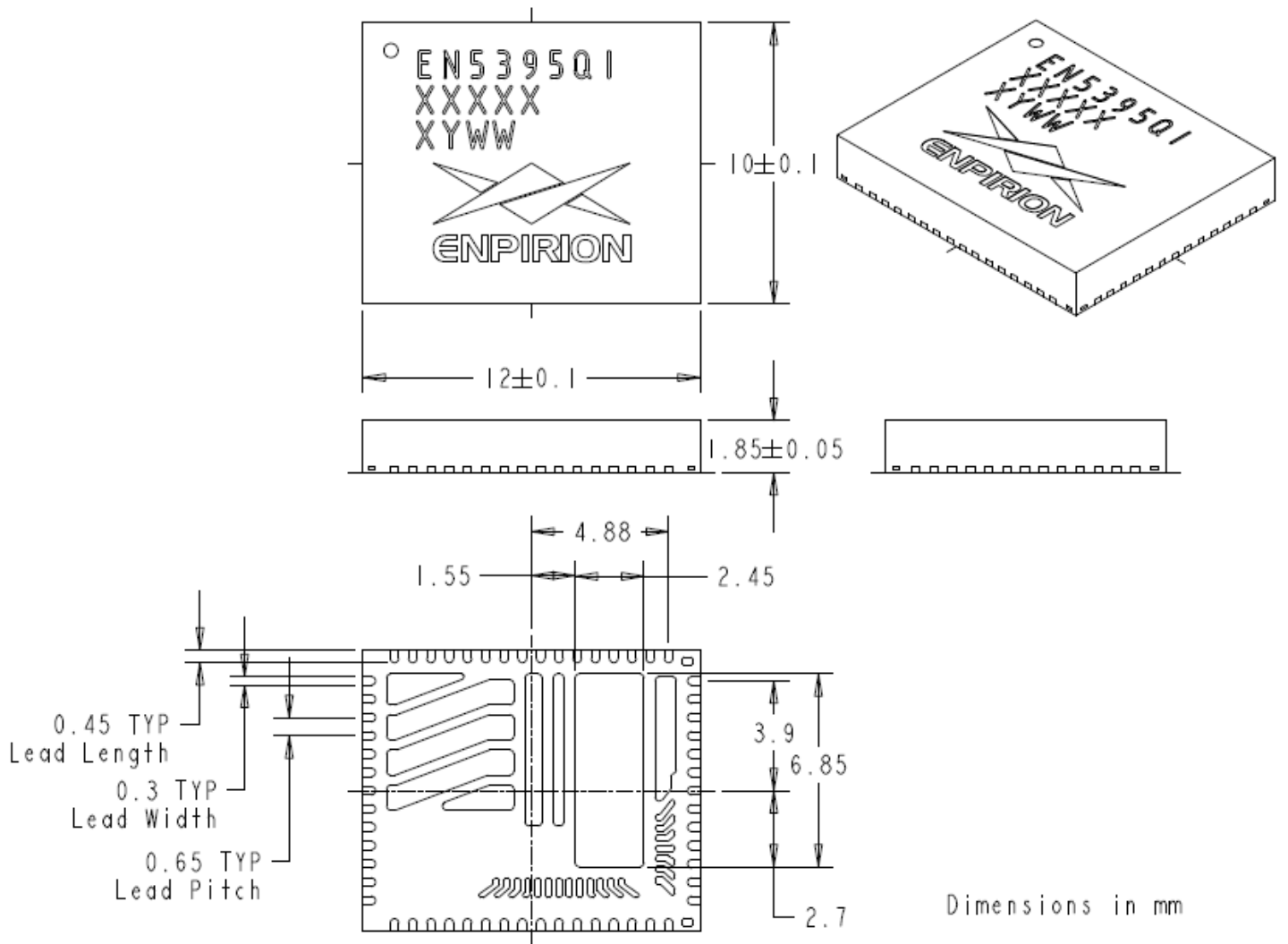

Figure 11: EN5395Q1 Package Dimensions (Bottom View)

Packing and Marking Information: <https://www.altera.com/support/quality-and-reliability/packing.html>

## REVISION HISTORY

Rev	Date	Change(s)
H	Nov, 2018	Changed datasheet into Intel format.

## WHERE TO GET MORE INFORMATION

For more information about Intel® and Enpirion® PowerSoCs, visit:

[www.altera.com/enpirion](http://www.altera.com/enpirion)

© 2017 Intel Corporation. All rights reserved. Intel, the Intel logo, Altera, ARRIA, CYCLONE, ENPIRION, MAX, MEGACORE, NIOS, QUARTUS, and STRATIX words and logos are trademarks of Intel Corporation or its subsidiaries in the U.S. and/or other countries. Other marks and brands may be claimed as the property of others. Intel reserves the right to make changes to any products and services at any time without notice. Intel assumes no responsibility or liability arising out of the application or use of any information, product, or service described herein except as expressly agreed to in writing by Intel. Intel customers are advised to obtain the latest version of device specifications before relying on any published information and before placing orders for products or services.  
\* Other marks and brands may be claimed as the property of others.