

Absolute maximum ratings

($T_a=25^\circ\text{C}$)

Symbol	Ratings	Unit
V_{CB0}	120	V
V_{CEO}	120	V
V_{EBO}	6	V
I_c	5	A
I_{cP}	8 (PW \leq 1ms, $D_u\leq$ 50%)	A
I_B	0.5	A
P_T	5 ($T_a=25^\circ\text{C}$)	W
	25 ($T_c=25^\circ\text{C}$)	
V_{ISO}	1000 (Between fin and lead pin, AC)	V_{rms}
T_j	150	$^\circ\text{C}$
T_{stg}	-40 to +150	$^\circ\text{C}$
θ_{j-c}	5	$^\circ\text{C}/\text{W}$

Electrical characteristics

($T_a=25^\circ\text{C}$)

Symbol	Specification			Unit	Conditions
	min	typ	max		
I_{CB0}			10	μA	$V_{CB}=120\text{V}$
I_{EBO}			10	mA	$V_{EB}=6\text{V}$
V_{CEO}	120			V	$I_c=25\text{mA}$
h_{FE}	2000	5000	15000		$V_{CE}=2\text{V}$, $I_c=3\text{A}$
$V_{CE(sat)}$		1.0	1.5	V	$I_c=3\text{A}$, $I_B=3\text{mA}$
$V_{BE(sat)}$		1.6	2.0	V	
t_{on}		0.5		μs	$V_{CC}\approx 30\text{V}$,
t_{stg}		5.5		μs	$I_c=3\text{A}$,
t_f		1.5		μs	$I_{B1}=-I_{B2}=3\text{mA}$

Equivalent circuit diagram

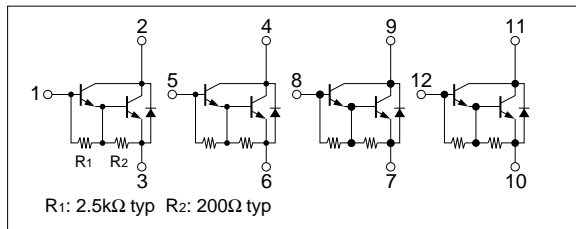

I_c - V_{CE} Characteristics (Typical)

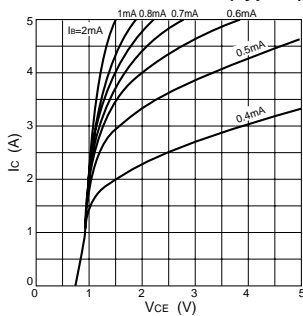

h_{FE} - I_c Characteristics (Typical)

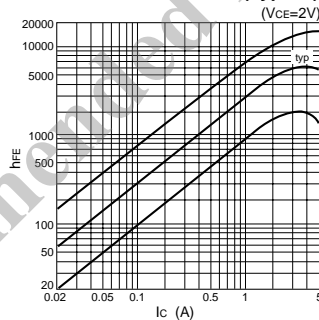

h_{FE} - I_c Temperature Characteristics (Typical)

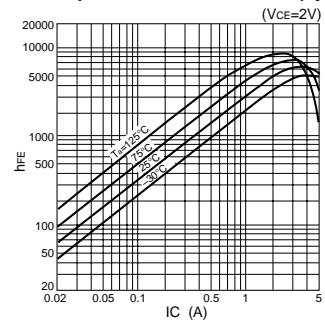

$V_{CE(sat)}$ - I_c Temperature Characteristics (Typical)

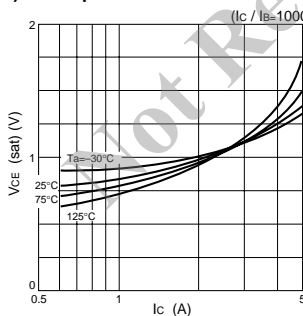

$V_{CE(sat)}$ - I_B Characteristics (Typical)

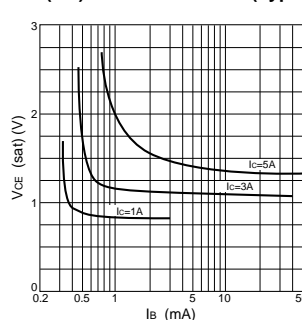

I_c - V_{BE} Temperature Characteristics (Typical)

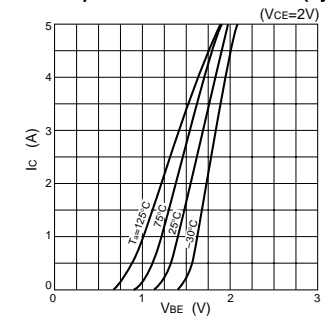

θ_{j-a} -PW Characteristics

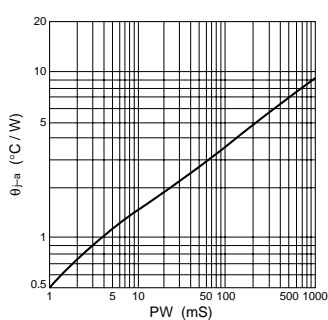

P_T - T_a Characteristics

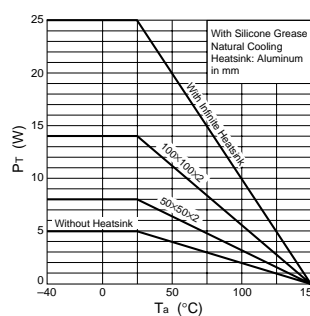

Safe Operating Area (SOA)

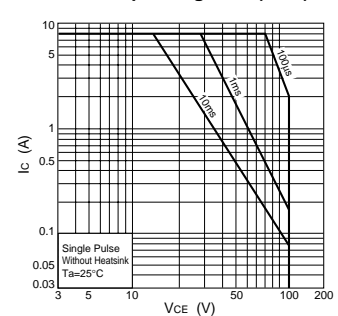

• SIP 8 (STA8Pin)

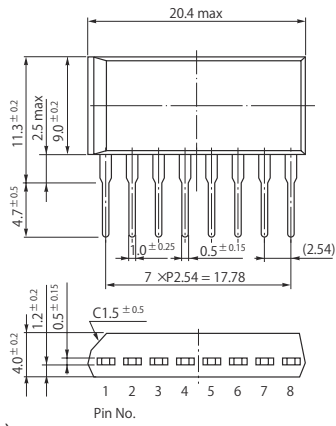

• SIP 10 (STA10Pin)

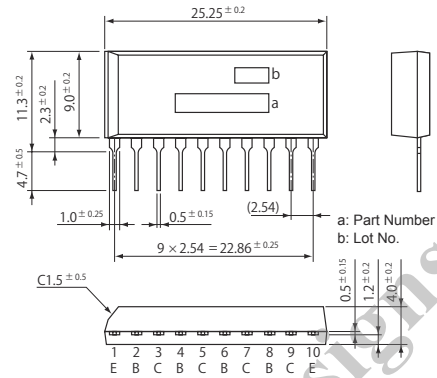

• SIP 12 (SMA12Pin)

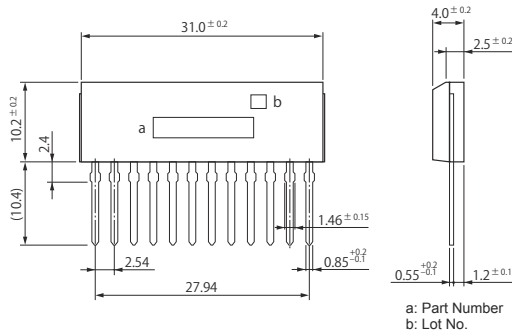

• SIP 15 (SMA15Pin)

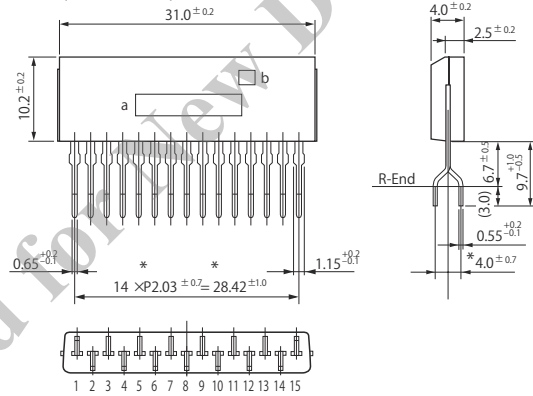

• SIP 12 with Fin (SLA12Pin)

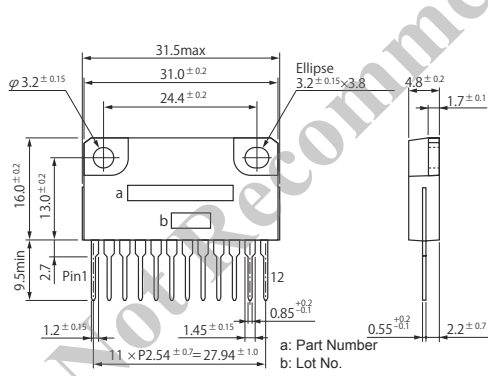

• SIP 15 with Fin (SLA15Pin)

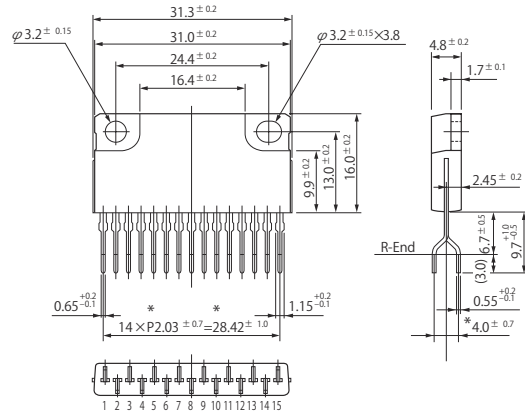

• SIP 21 with Fin (SLA21Pin)

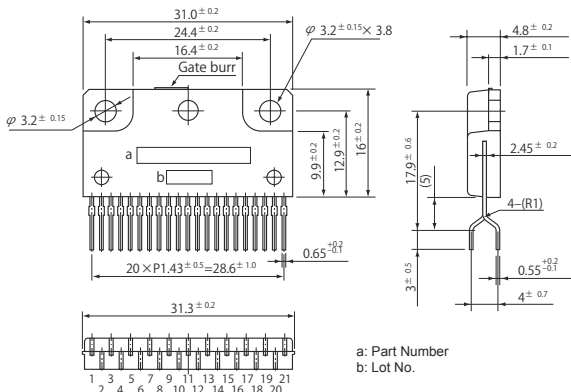

(Unit:mm)