

TMD2671

Digital Proximity Detector

General Description

The TMD2671 family of devices provides a complete proximity detection system and digital interface logic in a single 8-pin package. The proximity detector includes a digital proximity sensor with integrated LED driver, and IR LED. The proximity function is calibrated to 100mm (without cover glass), thus eliminating the need for end-equipment or sub-assembly factory calibration. The proximity detection feature operates from sunlight to dark rooms. The wide dynamic range also allows for operation in short distance detection behind dark glass such as with a cell phone. An internal state machine provides the ability to put the device into a low-power mode providing very low average power consumption. The addition of the micro-optics lenses within the module provide highly efficient transmission and reception of infrared energy, which lowers overall power dissipation for the detection function.

The proximity function specifically targets near-field proximity applications. In cell phones, the proximity detection can detect when the user positions the phone close to their ear. The device is fast enough to provide proximity information at a high repetition rate needed when answering a phone call. This provides both improved *green* power saving capability and the added security to lock the screen when the user may accidentally deploy a touch.

Communication with the device is accomplished with a simple 2-wire I²C interface with data rates up to 400kHz. An interrupt output pin is provided for connection to the host processor. This interrupt pin can be used to eliminate the need to poll the device on a repetitive basis. There is also a digital filter that compares the proximity ADC results to programmed values so that an interrupt is only generated upon a proximity event.

The TMD2671 is packaged in a very small form factor 8-pin optical package. The PCB board area required is only 9.36mm², which is far smaller than discrete solutions. Also, the package height is only 1.35mm, which makes the TMD2671 device suitable for very thin mechanical applications.

Ordering Information and Content Guide appear at end of datasheet.

Key Benefits & Features

The benefits and features of the TMD2671, Digital Proximity Detector are listed below:

Figure 1:
Added Value of Using TMD2671

Benefits	Features
<ul style="list-style-type: none"> Module reduces board space and design effort 	<ul style="list-style-type: none"> Integrated proximity detection sensor and IR LED
<ul style="list-style-type: none"> Enables operation in IR light environments 	<ul style="list-style-type: none"> Patented dual-diode architecture
<ul style="list-style-type: none"> Pre-calibration eliminates need for customer to end-product calibrate 	<ul style="list-style-type: none"> Proximity detection calibrated and trimmed to 100mm detection
<ul style="list-style-type: none"> Allows multiple power-level selection without external passives 	<ul style="list-style-type: none"> Programmable LED drive current

- Digital Proximity Detector, LED Driver, and IR LED in a Single Optical Module
- Proximity Detection
 - Calibrated to 100mm Detection
 - Integrated IR LED and Synchronous LED Driver
 - Programmable Number of IR Pulses
 - Programmable Current Sink for the IR LED - No Limiting Resistor Needed
 - Programmable Interrupt Function with Upper and Lower Threshold
- Programmable Wait Timer
 - Wait State - 65µA Typical Current
 - Programmable from 2.72ms to > 8s
- I²C Interface Compatible
 - Up to 400kHz (I²C Fast Mode)
- Sleep Mode - 2.5µA Typical
- Dedicated Interrupt Pin
- 3.94mm × 2.36mm × 1.35mm Package

Applications

The applications of this device include:

- Cell Phone Touch Screen Disable
- Automatic Speakerphone Enable
- Automatic Menu Popup

Block Diagram

The functional blocks of this device are shown below:

Figure 2:
TMD2671 Block Diagram

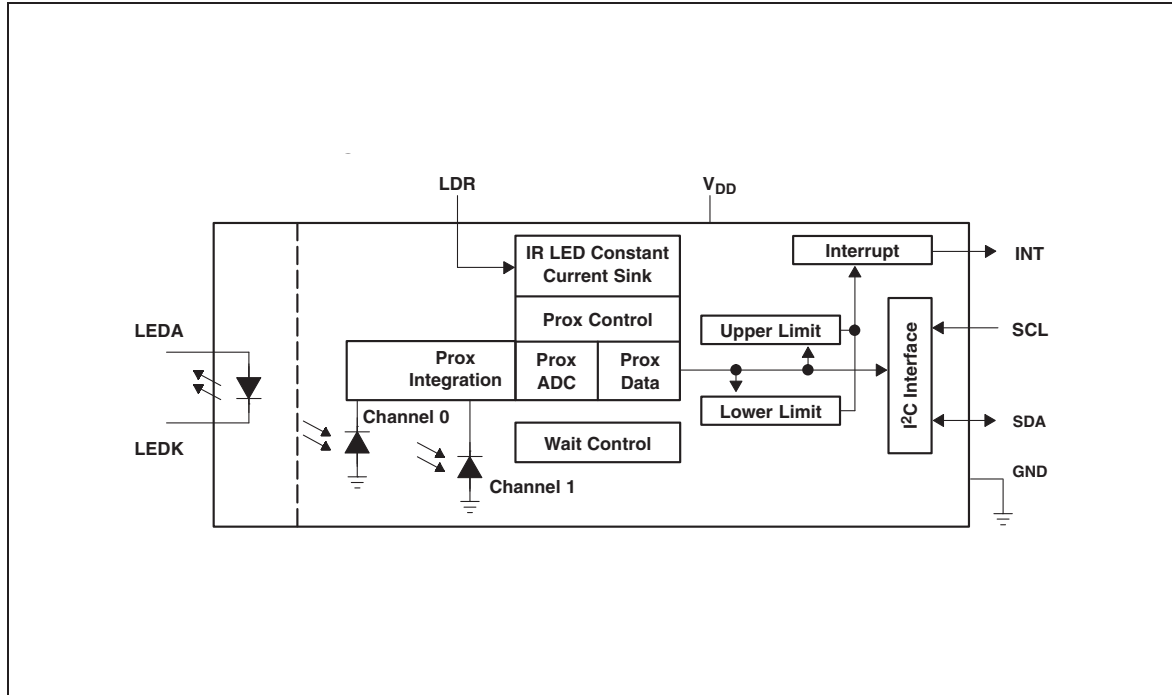

Detailed Description

A fully integrated proximity detection solution is provided with an 850nm IR LED, LED driver circuit, and proximity detection engine. An internal LED driver (LDR) pin, is connected to the LED cathode (LEDK) to provide a factory calibrated proximity of 100mm, ± 20 mm. This is accomplished with a proprietary current calibration technique that accounts for all variances in silicon, optics, package, and most important, IR LED output power. This eliminates or greatly reduces the need for factory calibration that is required for most discrete proximity sensor solutions. While the *device* is factory calibrated at a given pulse count, the number of proximity LED pulses can be programmed from 1 to 255 pulses, which allows different proximity distances to be achieved. Each pulse has a 16 μ s period, with a 7.2 μ s on time.

The device provides a separate pin for level-style interrupts. When interrupts are enabled and a pre-set value is exceeded, the interrupt pin is asserted and remains asserted until cleared by the controlling firmware. The interrupt feature simplifies and improves system efficiency by eliminating the need to poll a sensor for a proximity value. An interrupt is generated when the value of a proximity conversion exceeds either an upper or lower threshold. In addition, a programmable interrupt persistence feature allows the user to determine how many consecutive exceeded thresholds are necessary to trigger an interrupt.

Pin Assignment

The TMD2671 pin assignment is described below:

Figure 3:
Pin Diagram of Package Module-8 (Top View)

Note: Package drawing is not to scale

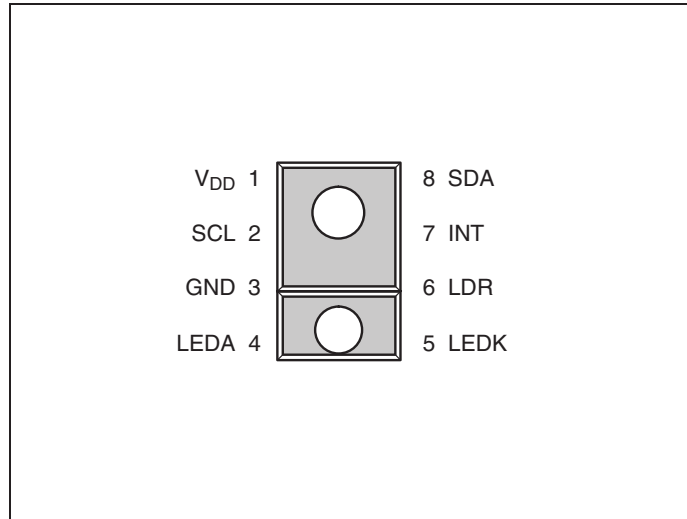

Figure 4:
Terminal Functions

Terminal		Type	Description
Name	No.		
V _{DD}	1		Supply voltage
SCL	2	I	I ² C serial clock input terminal - clock signal for I ² C serial data
GND	3		Power supply ground. All voltages are referenced to GND.
LEDA	4	I	LED anode
LEDK	5	O	LED cathode. Connect to LDR pin when using internal LED driver circuit.
LDR	6	I	LED driver input for proximity IR LED, constant current source LED driver
INT	7	O	Interrupt - open drain
SDA	8	I/O	I ² C serial data I/O terminal - serial data I/O for I ² C

Absolute Maximum Ratings

Stresses beyond those listed under “Absolute Maximum Ratings” may cause permanent damage to the device. These are stress ratings only. Functional operation of the device at these or any other conditions beyond those indicated under [Recommended Operating Conditions](#) is not implied. Exposure to absolute maximum rating conditions for extended periods may affect device reliability.

Figure 5:
Absolute Maximum Ratings over Operating Free-Air Temperature Range (unless otherwise noted)

Symbol	Parameter	Min	Max	Unit
V_{DD}	Supply voltage ⁽¹⁾		3.8	V
V_O	Digital output voltage range	-0.5	3.8	V
I_O	Digital output current	-1	20	mA
LDR	Analog voltage range	-0.5	3.8	V
T_{strg}	Storage temperature range	-40	85	°C
ESD_{HBM}	ESD tolerance, human body model	±2000		V

Note(s):

1. All voltages are with respect to GND.

Electrical Characteristics

All limits are guaranteed. The parameters with min and max values are guaranteed with production tests or SQC (Statistical Quality Control) methods.

Figure 6:
Recommended Operating Conditions

Symbol	Parameter	Min	Nom	Max	Unit
V_{DD}	Supply voltage	2.5	3	3.6	V
	Supply voltage accuracy, V_{DD} total error including transients	-3		3	%
T_A	Operating free-air temperature range ⁽¹⁾	-30		85	°C

Note(s):

1. While the device is operational across the temperature range, functionality will vary with temperature. Specifications are stated only at 25°C unless otherwise noted.

Figure 7:
Operating Characteristics, $V_{DD} = 3V$, $T_A = 25^\circ C$ (unless otherwise noted)

Symbol	Parameter	Test Conditions	Min	Typ	Max	Unit
I_{DD}	Supply current	Active: proximity and wait delay states		175	250	μA
		Wait state		65		
		Sleep state		2.5	4	
V_{OL}	INT, SDA output low voltage	3mA sink current	0		0.4	V
		6mA sink current	0		0.6	
I_{LEAK}	Leakage current, SDA, SCL, INT pins		-5		5	μA
I_{LEAK}	Leakage current, LDR pin				10	μA
V_{IH}	SCL, SDA input high voltage	TMD26711	$0.7 V_{DD}$			V
		TMD26713	1.25			
V_{IL}	SCL, SDA input low voltage	TMD26711			$0.3 V_{DD}$	V
		TMD26713			0.54	

Figure 8:
 Proximity Characteristics, $V_{DD} = V_{LEDA} = 3V$, $T_A = 25^\circ C$, $PEN = 1$ (unless otherwise noted)

Symbol	Parameter	Test Conditions	Min	Typ	Max	Unit
I_{DD}	Supply current - LDR pulse on			3		mA
	ADC conversion time step size	PTIME = 0xFF		2.72		ms
	ADC number of integration steps		1		256	steps
	ADC counts per step	PTIME = 0xFF	0		1023	counts
	Proximity IR LED pulse count		0		255	pulses
	Proximity pulse period			16.3		μs
I_{LEDA}	LED current @ V 600mV LDR pin sink ⁽¹⁾	PDRIVE = 0 (100% current)		100		mA
		PDRIVE = 1 (50% current)		50		
		PDRIVE = 2 (25% current)		25		
		PDRIVE = 3 (12.5% current)		12.5		
T_{LDR}	On time per pulse	PDRIVE = 1		7.2		μs
	Proximity response, no target (offset)	PDRIVE = 0, PPULSE = 8 ⁽²⁾		100		counts
	Prox count, 100mm target ⁽³⁾	73mm \times 83mm, 90% reflective Kodak Gray Card, PPULSE = 8, PDRIVE = 0, PTIME = 0xFF	414	520	624	counts

Note(s):

- Value is factory-adjusted to meet the Prox count specification. Considerable variation (relative to the typical value) is possible after adjustment.
- No reflective surface above the module. Proximity offset varies with power supply characteristics and noise.
- I_{LEDA} is factory calibrated to achieve this specification. Offset and crosstalk directly sum with this value and is system dependent.
- No glass or aperture above the module. Tested value is the average of 5 consecutive readings.
- These parameters are ensured by design and characterization and are not 100% tested.
- Proximity test was done using the following circuit. See [Application Information: Hardware](#) section for recommended application circuit.

Figure 9:
 Proximity Test Circuit

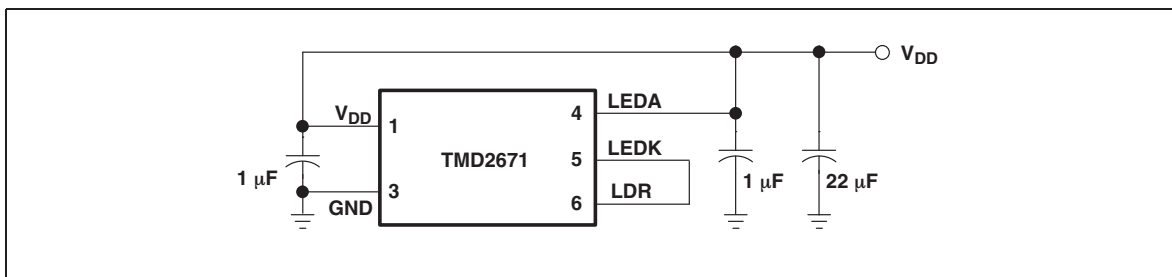

Figure 10:
IR LED Characteristics, $V_{DD} = 3V$, $T_A = 25^\circ C$

Symbol	Parameter	Test Conditions	Min	Typ	Max	Unit
V_F	Forward voltage	$I_F = 20mA$		1.4	1.5	V
V_R	Reverse voltage	$I_R = 10\mu A$	5			V
P_O	Radiant power	$I_F = 20mA$	4.5			mW
λ_p	Peak wavelength	$I_F = 20mA$		850		nm
$\Delta\lambda$	Spectral radiation bandwidth	$I_F = 20mA$		40		nm
T_R	Optical rise time	$I_F = 100mA$, $T_W = 125ns$, duty cycle = 25%		20	40	ns
T_F	Optical fall time	$I_F = 100mA$, $T_W = 125ns$, duty cycle = 25%		20	40	ns

Figure 11:
Wait Characteristics, $V_{DD} = 3V$, $T_A = 25^\circ C$, WEN = 1 (unless otherwise noted)

Parameter	Test Conditions	Min	Typ	Max	Unit
Wait step size	WTIME = 0xFF		2.72	2.9	ms
Wait number of integration steps		1		256	steps

Figure 12:
AC Electrical Characteristics, $V_{DD} = 3V$, $T_A = 25^\circ C$ (unless otherwise noted)

Symbol	Parameter ⁽¹⁾	Test Conditions	Min	Typ	Max	Unit
$f_{(SCL)}$	Clock frequency (I ² C only)		0		400	kHz
$t_{(BUF)}$	Bus free time between start and stop condition		1.3			μs
$t_{(HDSTA)}$	Hold time after (repeated) start condition. After this period, the first clock is generated.		0.6			μs
$t_{(SUSTA)}$	Repeated start condition setup time		0.6			μs
$t_{(SUSTO)}$	Stop condition setup time		0.6			μs
$t_{(HDDAT)}$	Data hold time		0			μs
$t_{(SUDAT)}$	Data setup time		100			ns
$t_{(LOW)}$	SCL clock low period		1.3			μs
$t_{(HIGH)}$	SCL clock high period		0.6			μs
t_F	Clock/data fall time				300	ns
t_R	Clock/data rise time				300	ns
C_i	Input pin capacitance				10	pF

Note(s):

1. Specified by design and characterization; not production tested.

Parameter Measurement Information

Figure 13:
Timing Diagrams

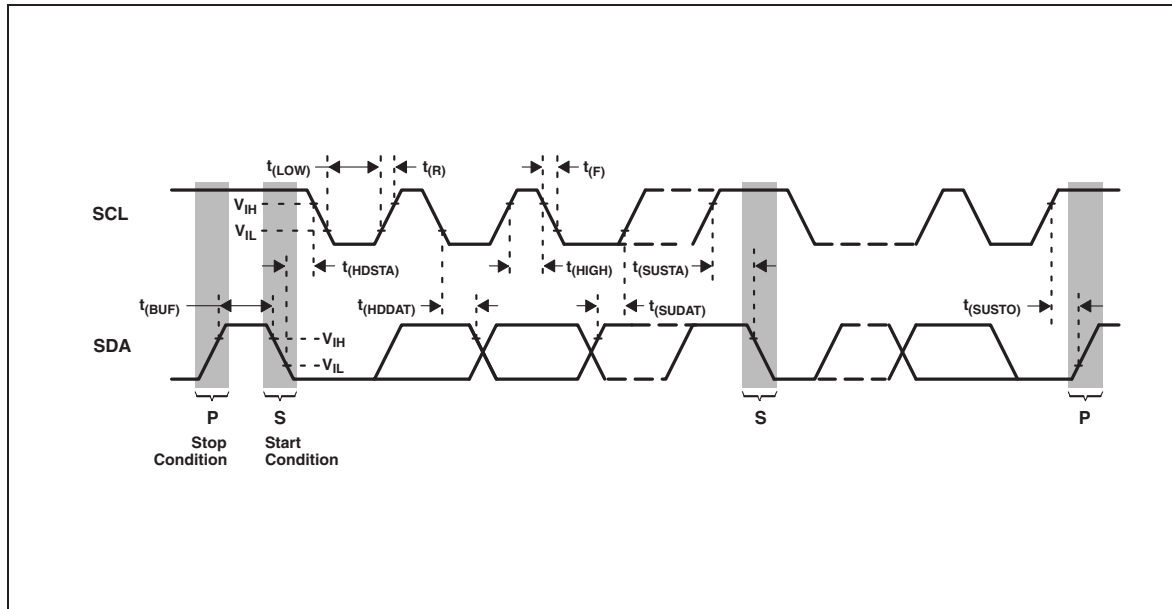

Typical Operating Characteristics

Figure 14:
Spectral Responsivity

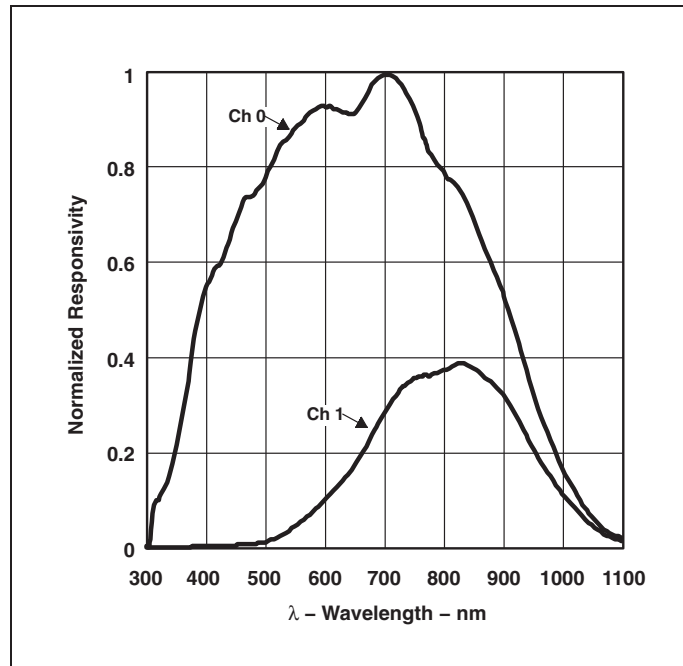

Figure 15:
LDR Output Compliance

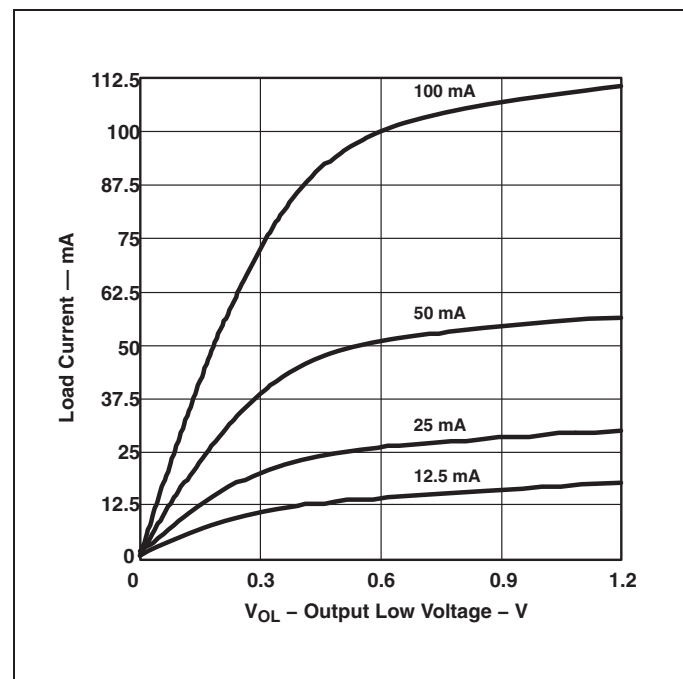
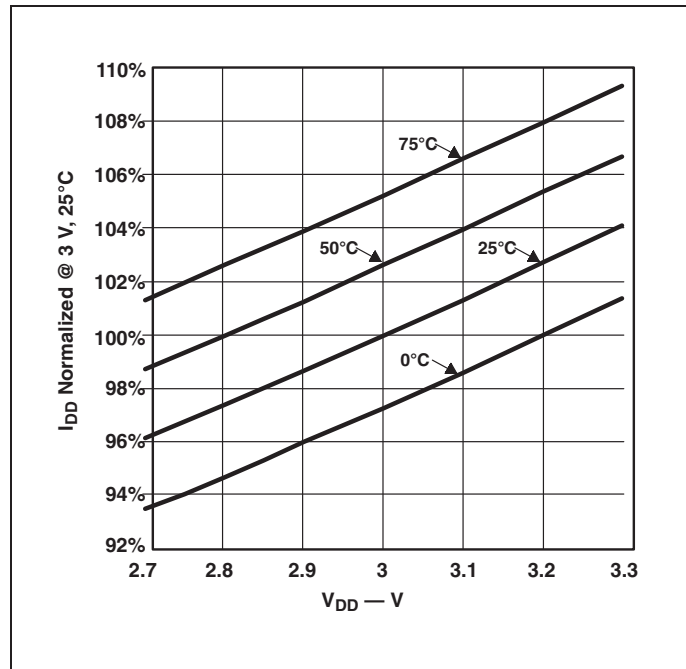

Figure 16:
Normalized I_{DD} vs. V_{DD} and Temperature



Principles of Operation

System State Machine

The device provides control of proximity detection and power management functionality through an internal state machine. After a power-on-reset, the device is in the sleep mode. As soon as the PON bit is set, the device will move to the start state. It will then cycle through the Proximity and Wait states. If these states are enabled, the device will execute each function. If the PON bit is set to a 0, the state machine will continue until the current conversion is complete and then go into a low-power sleep mode.

Figure 17:
Simplified State Diagram

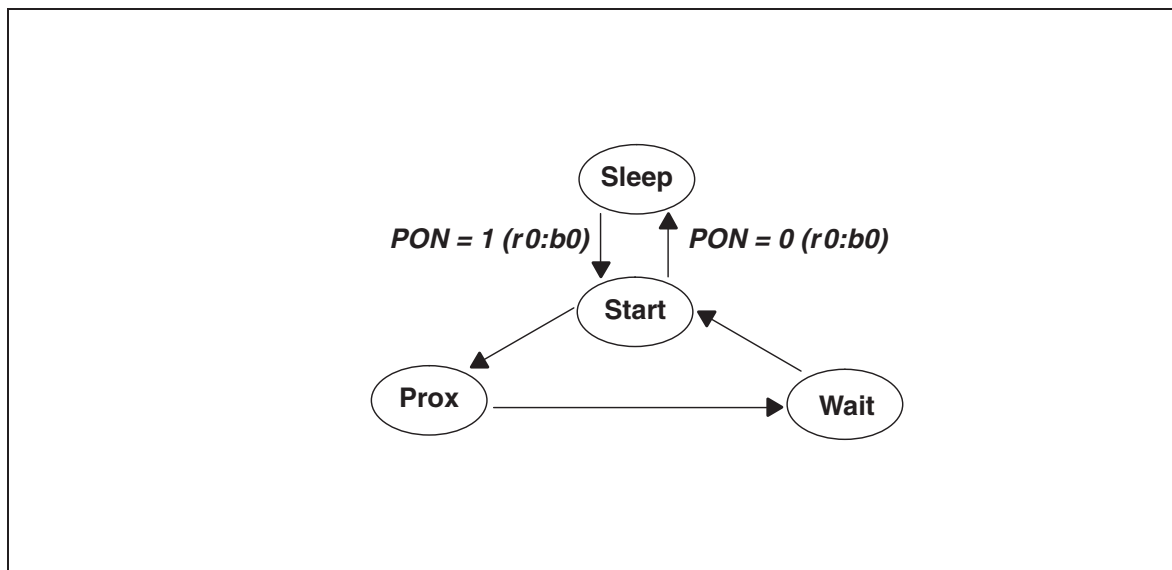

Note: In this document, the nomenclature uses the bit field name in italics followed by the register number and bit number to allow the user to easily identify the register and bit that controls the function. For example, the power on (PON) is in register 0, bit 0. This is represented as *PON (r0:b0)*.

Proximity Detection

Proximity detection is accomplished by measuring the amount of IR energy, from the internal IR LED, reflected off an object to determine its distance. The internal proximity IR LED is driven by the integrated proximity LED current driver as shown in Figure 18.

Figure 18:
Proximity Detection

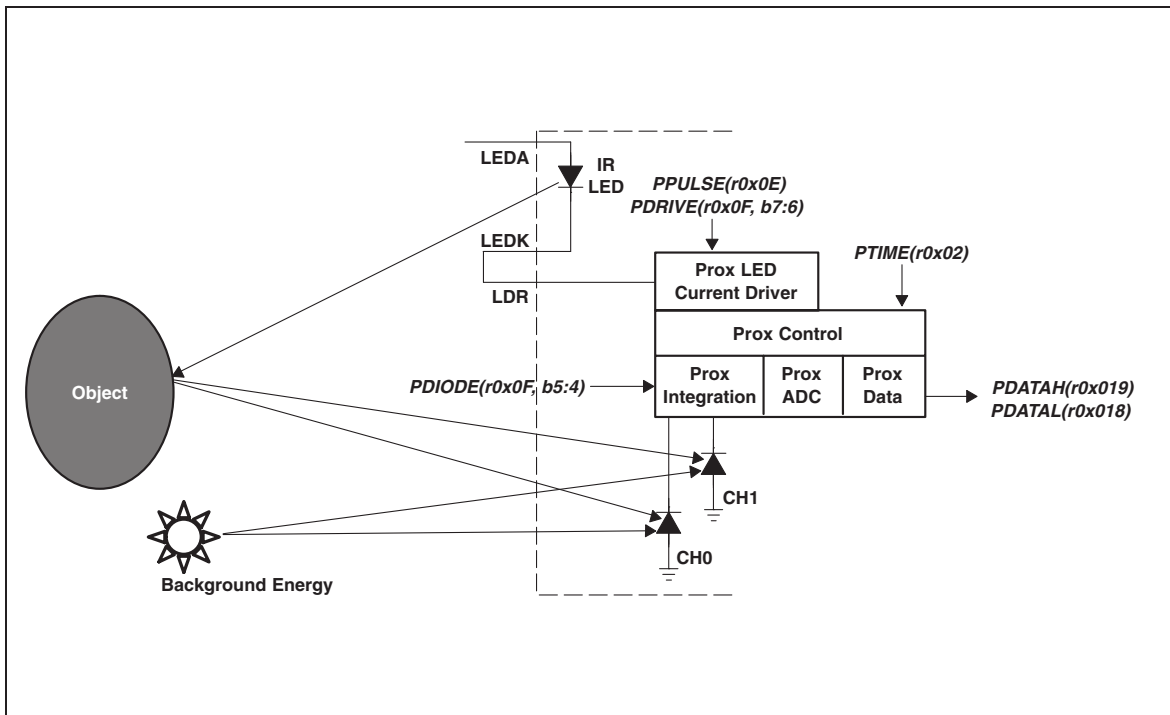

The LED current driver provides a regulated current sink on the LDR terminal that eliminates the need for an external current limiting resistor. The PDRIVE register setting sets the sink current to 100%, 50%, 25%, or 12.5% of the factory trimmed full scale current.

Referring to the Detailed State Machine figure, the LED current driver pulses the IR LED as shown in Figure 19 during the Prox Accum state. Figure 19 also illustrates that the LED On pulse has a fixed width of 7.3 μ s and period of 16.0 μ s. So, in addition to setting the proximity drive current, 1 to 255 proximity pulses (PPULSE) can be programmed. When deciding on the number of proximity pulses, keep in mind that the signal increases proportionally to PPULSE, while noise increases by the square root of PPULSE.

Figure 19:
Proximity LED Current Driver Waveform

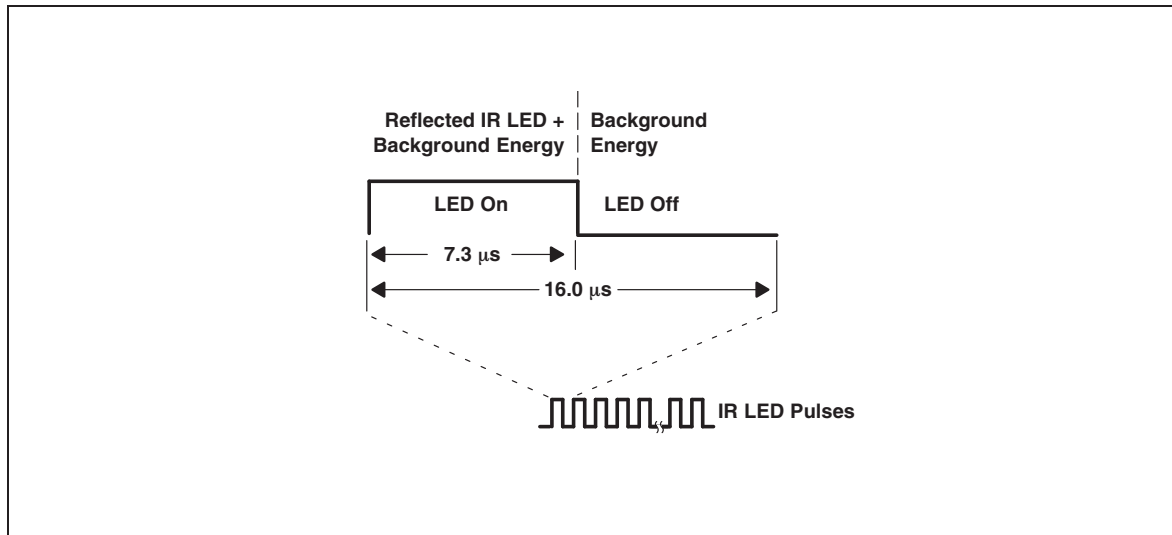

Figure 18 illustrates light rays emitting from the internal IR LED, reflecting off an object, and being absorbed by the CH0 and CH1 photodiodes. The proximity diode selector (PDIODE) determines which of the two photodiodes is used for a given proximity measurement. Note that neither photodiode is selected when the device first powers up, so PDIODE must be set for proximity detection to work.

Referring again to Figure 19, the reflected IR LED and the background energy is integrated during the LED On time, then during the LED Off time, the integrated background energy is subtracted from the LED On time energy, leaving the IR LED energy to accumulate from pulse to pulse.

After the programmed number of proximity pulses have been generated, the proximity ADC converts and scales the proximity measurement to a 16-bit value, then stores the result in two 8-bit proximity data (PDATAx) registers. ADC scaling is controlled by the proximity ADC conversion time (PTIME) which is programmable from 1 to 256 2.73ms time units. However, depending on the application, scaling the proximity data will equally scale any accumulated noise. Therefore, in general, it is recommended to leave PTIME at the default value of one 2.73ms ADC conversion time (0xFF).

For additional information on using the proximity detection function behind glass and for optical system design guidance, please see available **ams** application notes.

Optical Design Considerations

The TMD2671 device simplifies the optical system design by integrating an IR LED into the package, and also by providing an effective barrier between the LED and proximity sensor. In addition the package contains integrated lenses and apertures over both the LED and the sensor, which significantly extends the maximum proximity detection distance and helps to reduce optical crosstalk.

Although the package integrates an optical barrier between the IR LED and detector, placing the device behind a cover glass potentially provides another significant path for IR light to reach the detector, via reflection from the inside and outside faces of the cover glass. Because it is cost prohibitive to use anti-reflection coatings on the glass, the faces of the glass will reflect significantly (typically on the order of 4% of the light), and it is crucial that the system be designed so that this reflected light cannot find an efficient path back to the optical detector. See **ams** Application Note DN28: *Proximity Detection Behind Glass* for a detailed discussion of optical design considerations.

Interrupts

The interrupt feature simplifies and improves system efficiency by eliminating the need to poll the sensor for a proximity value. The interrupt mode is determined by the state of the PIEN field in the ENABLE register.

Two 16-bit-wide interrupt threshold registers allow the user to define upper and lower threshold limits. An interrupt can be generated when the proximity data (PDATA) exceeds the upper threshold value (PIHTx) or falls below the lower threshold (PILTx).

To further control when an interrupt occurs, the device provides an interrupt persistence feature. This feature allows the user to specify a number of conversion cycles for which an event exceeding the proximity interrupt threshold must persist (PPERS) before actually generating an interrupt. See the register descriptions for details on the length of the persistence.

Figure 20:
Programmable Interrupt

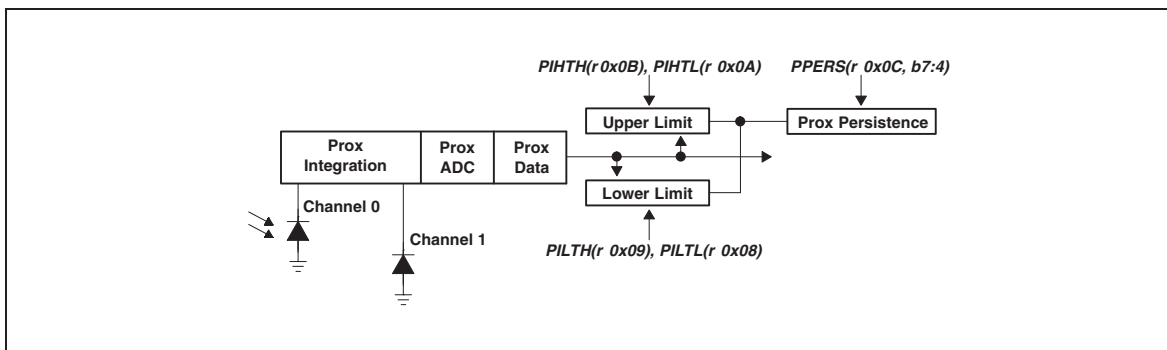

State Diagram

The following state diagram shows a more detailed flow for the state machine. The device starts in the sleep mode. The PON bit is written to enable the device. A 2.72ms Start Delay will occur before entering the start state. If the PEN bit is set, the state machine will step through the proximity accumulate, then proximity ADC conversion states. As soon as the conversion is complete, the state machine will move to the Wait Check state. If the WEN bit is set, the state machine will then cycle through the wait state. If the WLONG bit is set, the wait cycles are extended by 12x over normal operation. When the wait counter terminates, the state machine will move to the 2.72ms Wait Delay state before returning to the Start state.

Figure 21:
Expanded State Diagram

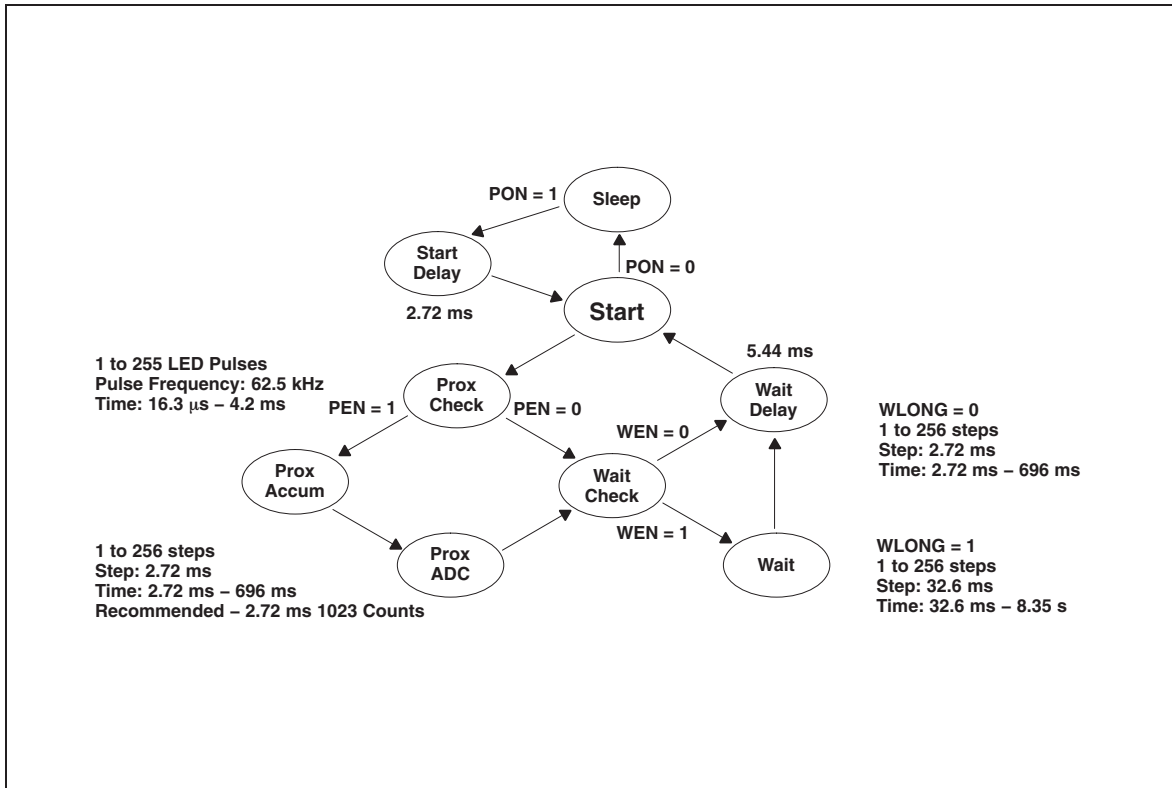

Power Management

Power consumption can be controlled through the use of the wait state timing because the wait state consumes only 65µA of power. Figure 22 shows an example of using the power management feature to achieve an average power consumption of 136µA current with four 100mA pulses of proximity detection.

Figure 22:
Power Consumption Calculations

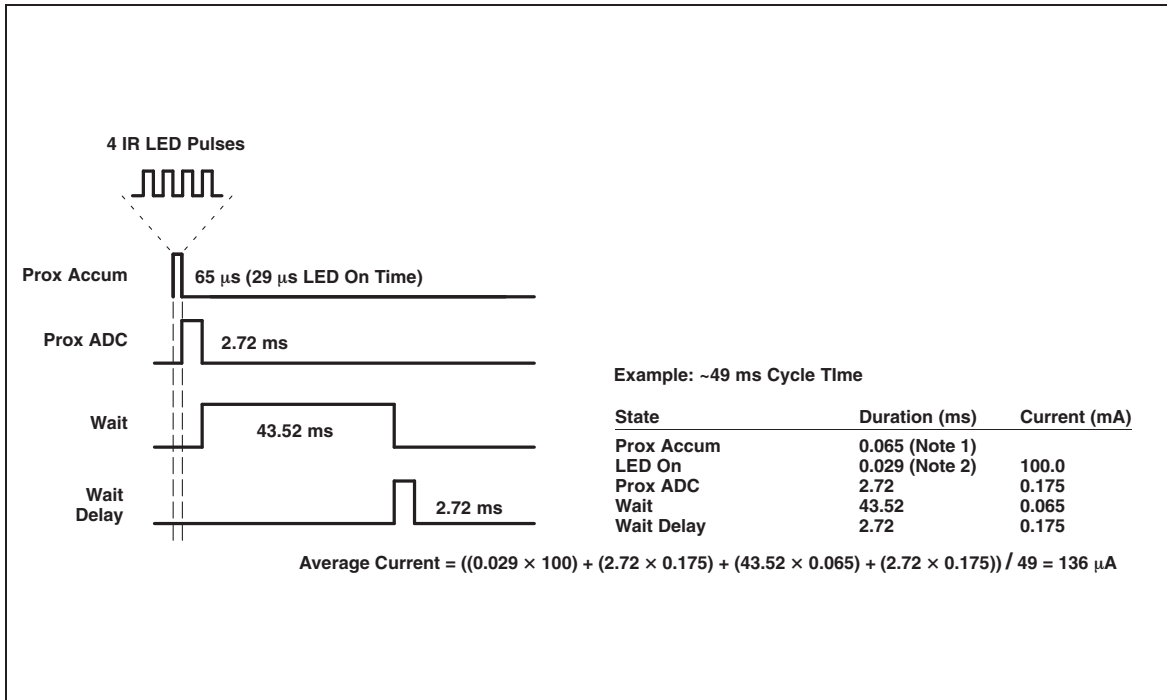

Note(s):

1. Prox Accum = 16.3µs per pulse x 4 pulses = 65µs = 0.065ms
2. LED On = 7.2µs per pulse x 4 pulses = 29µs = 0.029ms

I²C Protocol

Interface and control are accomplished through an I²C serial compatible interface (standard or fast mode) to a set of registers that provide access to device control functions and output data. The devices support the 7-bit I²C addressing protocol.

The I²C standard provides for three types of bus transaction: read, write, and a combined protocol (Figure 23). During a write operation, the first byte written is a command byte followed by data. In a combined protocol, the first byte written is the command byte followed by reading a series of bytes. If a read command is issued, the register address from the previous command will be used for data access. Likewise, if the MSB of the command is not set, the device will write a series of bytes at the address stored in the last valid command with a register address. The command byte contains either control information or a 5-bit register address. The control commands can also be used to clear interrupts.

The I²C bus protocol was developed by Philips (now NXP). For a complete description of the I²C protocol, please review the NXP I²C design specification at <http://www.i2c-bus.org/references>.

Figure 23:
I²C Protocols

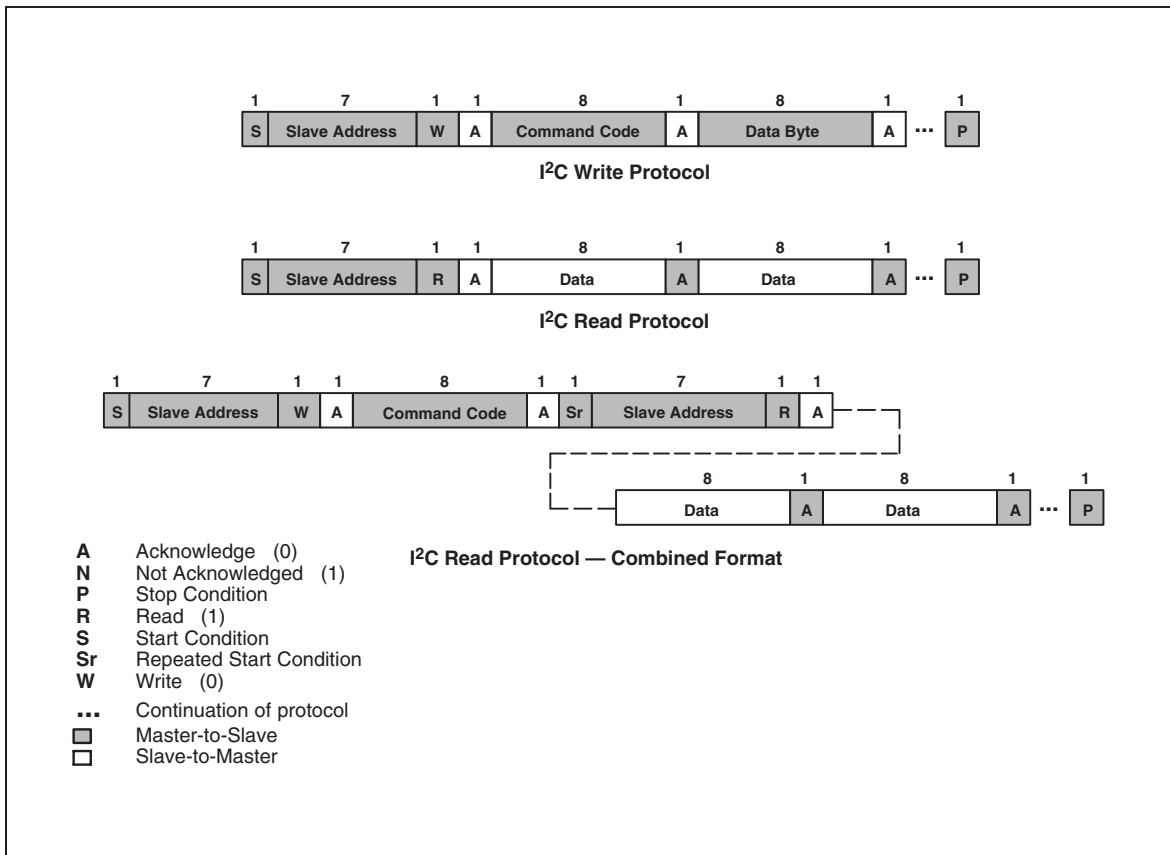

Register Set

The device is controlled and monitored by data registers and a command register accessed through the serial interface. These registers provide for a variety of control functions and can be read to determine results of the ADC conversions. The Register Set is summarized in [Figure 24](#).

Figure 24:
Register Address

Address	Register Name	R/W	Register Function	Reset Value
----	COMMAND	W	Specifies register address	0x00
0x00	ENABLE	R/W	Enables states and interrupts	0x00
0x01	ATIME	R/W	ALS ADC time	0x00 ⁽¹⁾
0x02	PTIME	R/W	Proximity ADC time	0xFF
0x03	WTIME	R/W	Wait time	0xFF
0x08	PILTL	R/W	Proximity interrupt low threshold low byte	0x00
0x09	PILTH	R/W	Proximity interrupt low threshold high byte	0x00
0x0A	PIHTL	R/W	Proximity interrupt high threshold low byte	0x00
0x0B	PIHTH	R/W	Proximity interrupt high threshold high byte	0x00
0x0C	PERS	R/W	Interrupt persistence filter	0x00
0x0D	CONFIG	R/W	Configuration	0x00
0x0E	PPULSE	R/W	Proximity pulse count	0x00
0x0F	CONTROL	R/W	Control register	0x00
0x12	ID	R	Device ID	ID
0x13	STATUS	R	Device status	0x00
0x18	PDATAH	R	Proximity ADC low data register	0x00
0x19	PDATAH	R	Proximity ADC high data register	0x00

Note(s):

1. Following power on, this register should be initialized to 0xFF.

The mechanics of accessing a specific register depends on the specific protocol used. See the section on I²C protocols on the previous pages. In general, the Command Register is written first to specify the specific control/status register for following read/write operations.

Command Register

The Command Registers specifies the address of the target register for future write and read operations.

Figure 25:
Command Register

	7	6	5	4	3	2	1	0
COMMAND	TYPE			ADD				

Field	Bits	Description	
COMMAND	7	Select Command Register. Must write as 1 when addressing COMMAND register.	
TYPE	6:5	Selects type of transaction to follow in subsequent data transfers:	
		Field Value	Description
		00	Repeated byte protocol transaction
		01	Auto-increment protocol transaction
		10	Reserved - Do not use
		11	Special function - See description below
		Transaction type 00 will repeatedly read the same register with each data access. Transaction type 01 will provide an auto-increment function to read successive register bytes.	
ADD	4:0	Address register/special function register. Depending on the transaction type, see above, this field either specifies a special function command or selects the specific control-status-register for following write and read transactions:	
		Field Value	Description
		00000	Normal - no action
		00101	Proximity interrupt clear
		Proximity Interrupt Clear clears any pending proximity interrupt. This special function is self clearing.	

Enable Register (0x00)

The Enable Register is used to power the device on/off, enable functions, and interrupts.

Figure 26:
Enable Register

	7	6	5	4	3	2	1	0
	Reserved	PIEN	Reserved	WEN	PEN	PEN	PEN	PON

Field	Bits	Description
Reserved	7:6	Reserved. Write as 0.
PIEN	5	Proximity Interrupt Mask. When asserted, permits proximity interrupts to be generated.
Reserved	4	Reserved. Write as 0.
WEN	3	Wait Enable. This bit activates the wait feature. Writing a 1 activates the wait timer. Writing a 0 disables the wait timer.
PEN	2:1	Proximity Enable. These bits activate the proximity function. Writing a 11b enables proximity. Writing a 00b disables proximity. The Wait Time Register should be configured before asserting proximity enable.
PON ^{(1), (2)}	0	Power ON. This bit activates the internal oscillator to permit the timers and ADC channel to operate. Writing a 1 activates the oscillator. Writing a 0 disables the oscillator.

Note(s):

1. See [Power Management](#) section for more information.
2. A minimum interval of 2.72ms must pass after PON is asserted before proximity can be initiated. This required time is enforced by the hardware in cases where the firmware does not provide it.

ALS Timing Register (0x01)

Although this part is proximity only, the ATIME period still occurs. Note that the power-on default value is 0x00 (the longest duration). This register should be initialized by the application code to 0xFF.

Figure 27:
ALS Timing Register

Field	Bits	Description		
ATIME	7:0	Value	INTEG_CYCLES	Time
		0xFF	1	2.72ms
		0x00	256	696ms

Proximity Time Control Register (0x02)

The Proximity Timing Register controls the integration time of the proximity ADC in 2.72ms increments. It is recommended that this register be programmed to a value of 0xFF (1 integration cycle).

Figure 28:
Proximity Time Control Register

Field	Bits	Description			
		Value	INTEG_CYCLES	Time	Max Count
PTIME	7:0	0xFF	1	2.72ms	1023

Wait Time Register (0x03)

Wait time is set 2.72ms increments unless the WLONG bit is asserted, in which case the wait times are 12× longer. WTIME is programmed as a 2's complement number.

Figure 29:
Wait Time Register

Field	Bits	Description			
		REGISTER VALUE	WAIT TIME	TIME (WLONG = 0)	TIME (WLONG = 1)
WTIME	7:0	0xFF	1	2.72ms	0.032 s
		0xB6	74	200ms	2.4 s
		0x00	256	700ms	8.3 s

Note(s):

1. The Wait Time Register should be configured before PEN is asserted.

Proximity Interrupt Threshold Register (0x08 – 0x0B)

The Proximity Interrupt Threshold Registers provide the values to be used as the high and low trigger points for the comparison function for interrupt generation. If the value generated by proximity channel crosses below the lower threshold specified, or above the higher threshold, an interrupt is signaled to the host processor.

Figure 30:
Proximity Interrupt Threshold Register

Register	Address	Bits	Description
PILTL	0x08	7:0	Proximity low threshold lower byte
PILTH	0x09	7:0	Proximity low threshold upper byte
PIHTL	0x0A	7:0	Proximity high threshold lower byte
PIHTL	0x0B	7:0	Proximity high threshold upper byte

Persistence Register (0x0C)

The Persistence Register controls the filtering interrupt capabilities of the device. Configurable filtering is provided to allow interrupts to be generated after each ADC integration cycle or if the ADC integration has produced a result that is outside of the values specified by threshold register for some specified amount of time.

Figure 31:
Persistence Register

7	6	5	4	3	2	1	0
PPERS				Reserved			

Field	Bits	Description		
PPERS	7:4	Proximity Interrupt Persistence. Controls rate of proximity interrupt to the host processor.		
		Field Value	Meaning	Interrupt Persistence Function
		0000	...	Every proximity cycle generates an interrupt
		0001	1	1 proximity value out of range
		0010	2	2 consecutive proximity values out of range
	
1111	15	15 consecutive proximity values out of range		
Reserved	3:0	Default setting is 0x00.		

Configuration Register (0x0D)

The Configuration Register sets the wait long time.

Figure 32:
Configuration Register

7	6	5	4	3	2	1	0
Reserved						WLONG	Reserved

Field	Bits	Description
Reserved	7:2	Reserved. Write as 0.
WLONG	1	Wait Long. When asserted, the wait cycles are increased by a factor 12× from that programmed in the WTIME register.
Reserved	0	Reserved. Write as 0.

Proximity Pulse Count Register (0x0E)

The Proximity Pulse Count Register sets the number of proximity pulses that will be transmitted. PPULSE defines the number of pulses to be transmitted at a 62.5kHz rate.

While the value can be programmed up to 255 pulses, the practical limit of the device is 32 pulses. It is recommended that 32 or fewer pulses be used to achieve maximum signal-to-noise ratio.

Figure 33:
Proximity Pulse Count Register

7	6	5	4	3	2	1	0
PPULSE							

Field	Bits	Description
PPULSE	7:0	Proximity Pulse Count. Specifies the number of proximity pulses to be generated.

Control Register (0x0F)

The Control Register provides four bits of control to the analog block. These bits control the diode drive current and diode selection functions.

Figure 34:
Control Register

	7	6	5	4	3	2	1	0
	PDRIVE		PDIODE		Reserved			

Field	Bits	Description	
PDRIVE	7:6	LED Drive Strength.	
		Field Value	LED Strength
		00	100%
		01	50%
		10	25%
		11	12.5%
PDIODE	5:4	Proximity Diode Select.	
		Field Value	Diode Selection
		00	Reserved
		01	Proximity uses the Channel 0 diode
		10	Proximity uses the Channel 1 diode
		11	Proximity uses both diodes
Reserved	3:0	Reserved. Write bits as 0.	

Note(s):

1. The PDRIVE values are relative to the factory-trimmed current necessary to meet the Prox Coun specification shown on page 8.

ID Register (0x12)

The ID Register provides the value for the part number. The ID Register is a read-only register.

Figure 35:
ID Register

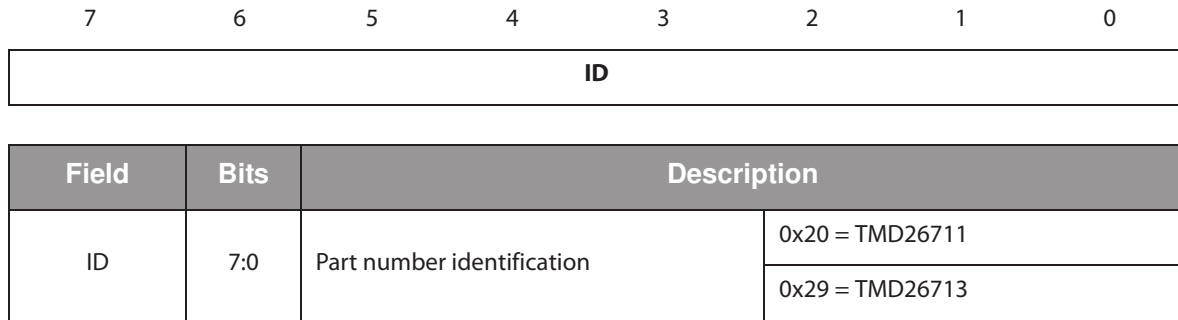

Status Register (0x13)

The Status Register provides the internal status of the device. This register is read only.

Figure 36:
Status Register

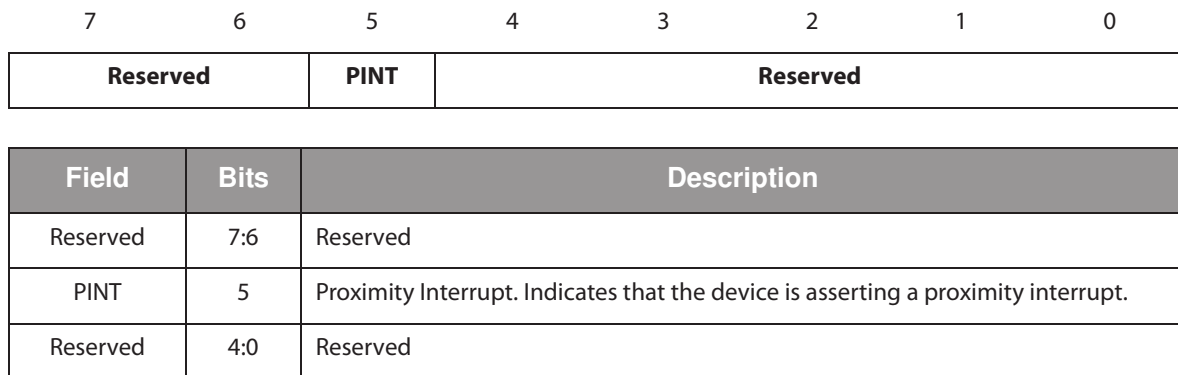

Proximity Data Register (0x18 - 0x19h)

Proximity data is stored as a 16-bit value. To ensure the data is read correctly, a two-byte I²C read transaction should be utilized with auto increment protocol bits set in the Command Register. With this operation, when the lower byte register is read, the upper eight bits are stored into a shadow register, which is read by a subsequent read to the upper byte. The upper register will read the correct value even if the next ADC cycle ends between the reading of the lower and upper registers.

Figure 37:
PDATA Registers

Register	Address	Bits	Description
PDATA_L	0x18	7:0	Proximity data low byte
PDATA_H	0x19	7:0	Proximity data high byte

**Application Information:
Hardware**

LED Driver Pin with Proximity Detection

In a proximity sensing system, the included IR LED can be pulsed with more than 100mA of rapidly switching current, therefore, a few design considerations must be kept in mind to get the best performance. The key goal is to reduce the power supply noise coupled back into the device during the LED pulses. Averaging of multiple proximity samples is recommended to reduce the proximity noise.

The first recommendation is to use two power supplies; one for the device V_{DD} and the other for the IR LED. In many systems, there is a quiet analog supply and a noisy digital supply. By connecting the quiet supply to the V_{DD} pin and the noisy supply to the LEDA pin, the key goal can be met. Place a $1\mu\text{F}$ low-ESR decoupling capacitor as close as possible to the V_{DD} pin and another at the LEDA pin, and a $22\mu\text{F}$ capacitor at the output of the LED voltage regulator to supply the 100mA current surge.

Figure 38:
Proximity Sensing Using Separate Power Supplies

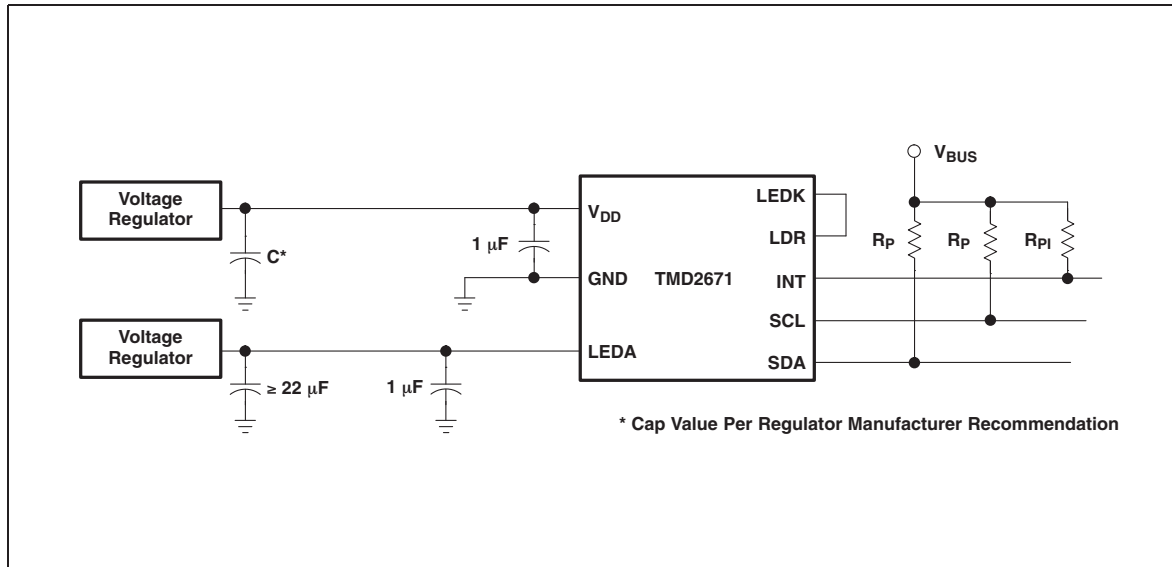

If it is not possible to provide two separate power supplies, the device can be operated from a single supply. A 22Ω resistor in series with the V_{DD} supply line and a $1\mu\text{F}$ low ESR capacitor effectively filter any power supply noise. The previous capacitor placement considerations apply.

Figure 39:
Proximity Sensing Using Single Power Supply

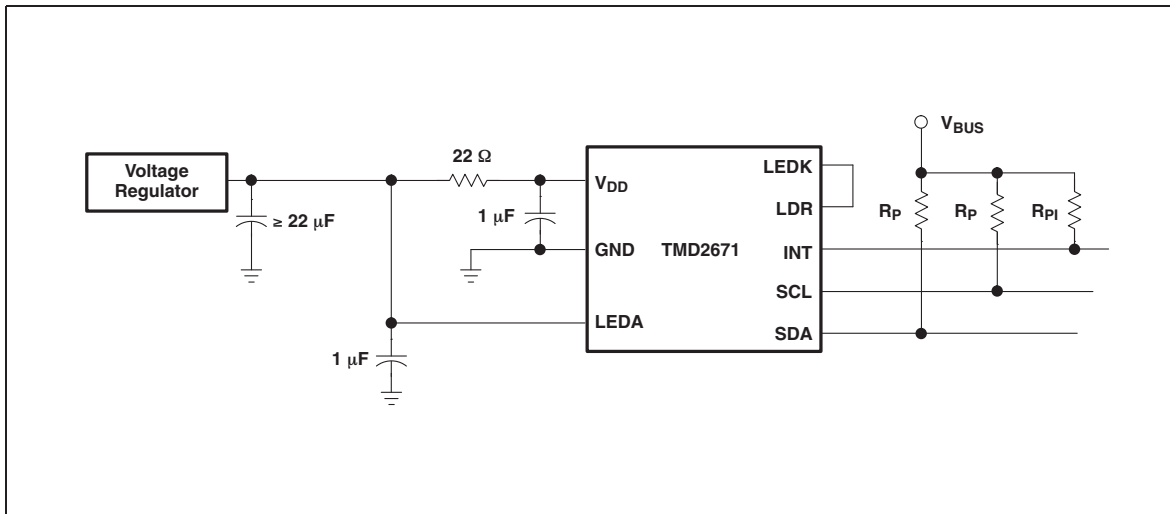

V_{BUS} in the above figures refers to the I²C bus voltage which is either V_{DD} or 1.8V. Be sure to apply the specified I²C bus voltage shown in the [Ordering Information](#) table for the specific device being used.

The I²C signals and the Interrupt are open-drain outputs and require pull-up resistors. The pull-up resistor (Rp) value is a function of the I²C bus speed, the I²C bus voltage, and the capacitive load. The **ams** EVM running at 400kbps, uses 1.5kΩ resistors. A 10kΩ pull-up resistor (RpI) can be used for the interrupt line.

PCB Pad Layout

Suggested PCB pad layout guidelines for the surface mount module are shown in Figure 40. Flash Gold is recommended surface finish for the landing pads.

Figure 40:
Suggested Module PCB Layout

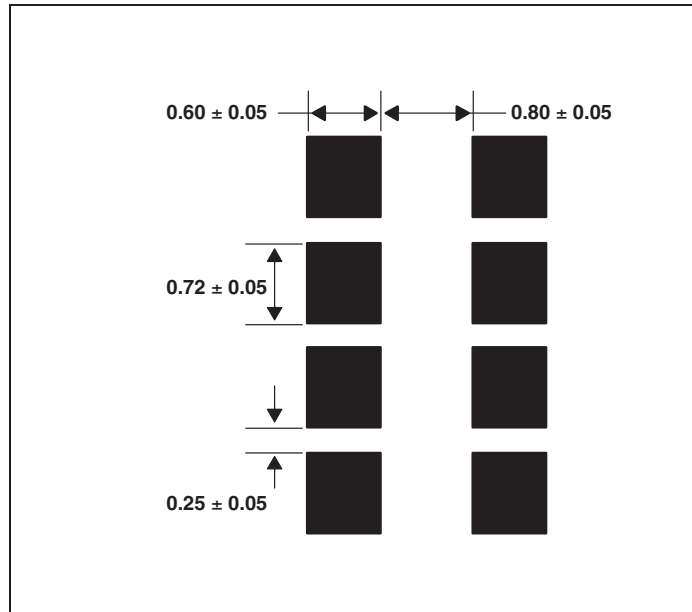

Note(s):

1. All linear dimensions are in mm.
2. This drawing is subject to change without notice.

Package Drawings & Markings

Figure 41:
Module Packaging Configuration

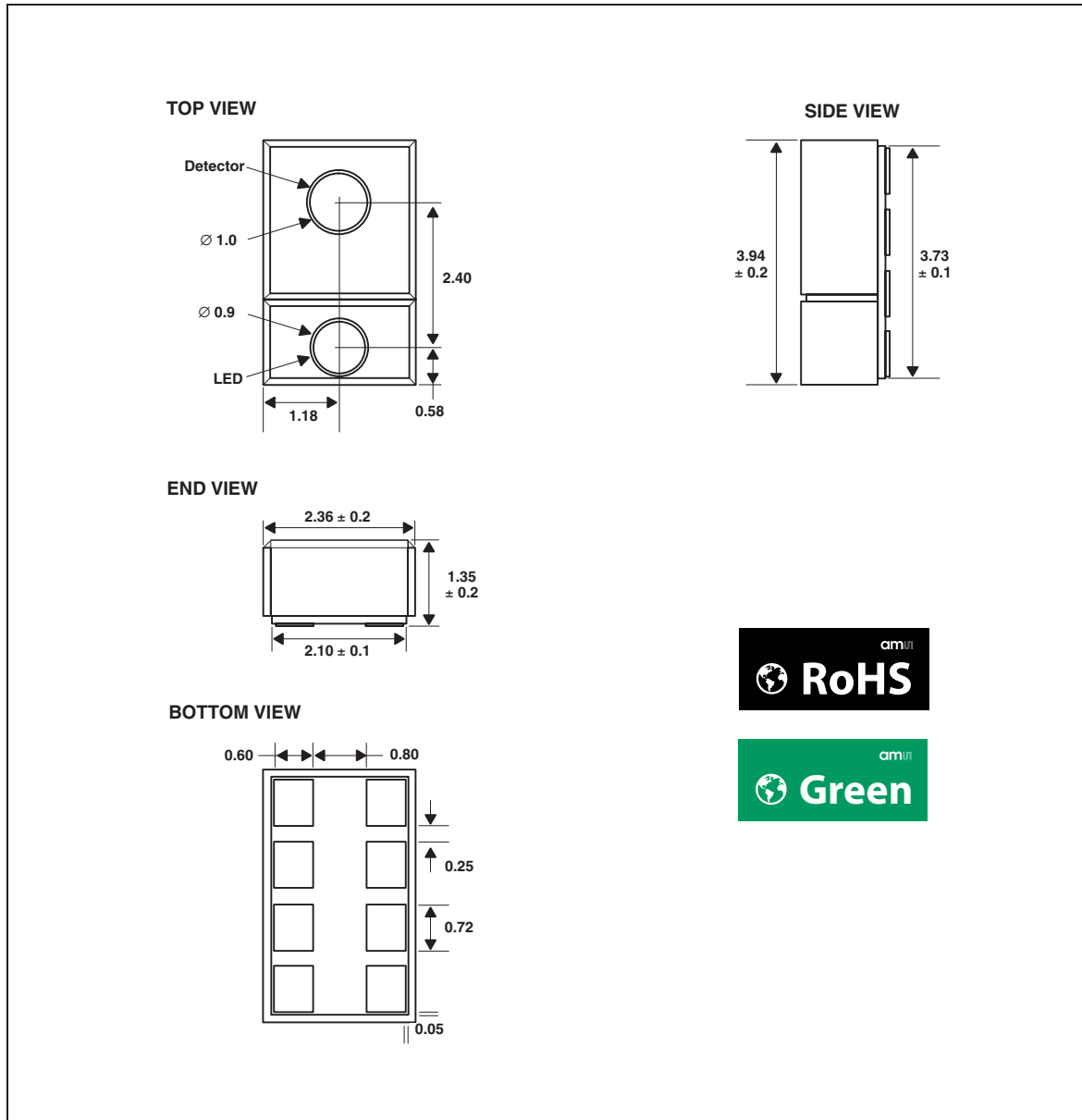

Note(s):

1. All linear dimensions are in millimeters. Dimension tolerance is $\pm 0.05\text{mm}$ unless otherwise noted.
2. Contacts are copper with NiPdAu plating.
3. This package contains no lead (Pb).
4. This drawing is subject to change without notice.

Package Mechanical Data

Figure 42:
Module Carrier Tape

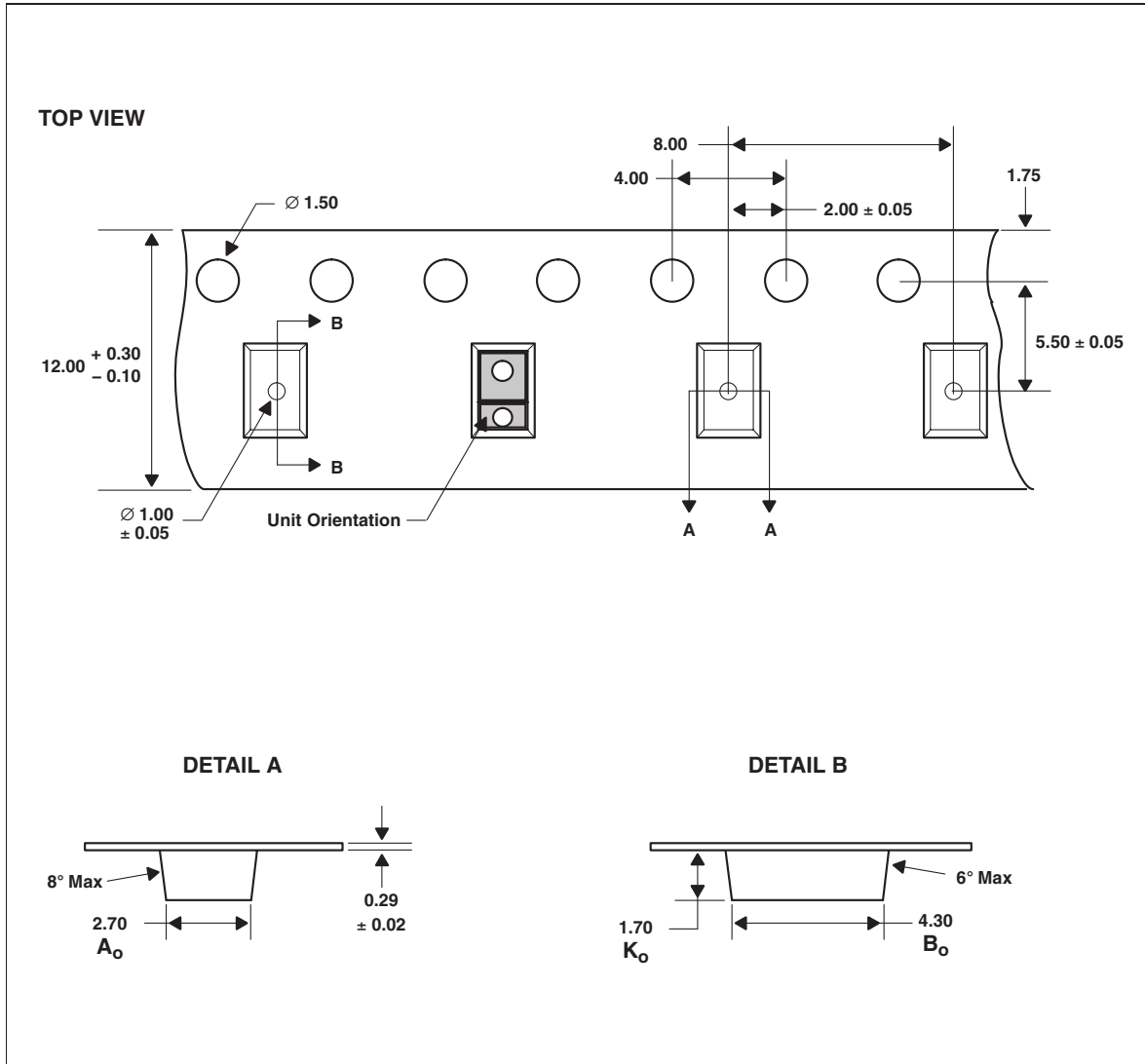

Note(s):

1. All linear dimensions are in millimeters. Dimension tolerance is ±0.10mm unless otherwise noted.
2. The dimensions on this drawing are for illustrative purposes only. Dimensions of an actual carrier may vary slightly.
3. Symbols on drawing A₀, B₀, and K₀ are defined in ANSI EIA Standard 481-B 2001.
4. Each reel is 330 millimeters in diameter and contains 2500 parts.
5. ams packaging tape and reel conform to the requirements of EIA Standard 481-B.
6. In accordance with EIA standard, device pin 1 is located next to the sprocket holes in the tape.
7. This drawing is subject to change without notice.

Soldering & Storage Information

The module has been tested and has demonstrated an ability to be reflow soldered to a PCB substrate. The process, equipment, and materials used in these test are detailed below.

The solder reflow profile describes the expected maximum heat exposure of components during the solder reflow process of product on a PCB. Temperature is measured on top of component. The components should be limited to a maximum of three passes through this solder reflow profile.

Figure 43:
Solder Reflow Profile

Parameter	Reference	Device
Average temperature gradient in preheating		2.5°C/s
Soak time	t_{soak}	2 to 3 minutes
Time above 217°C (T_1)	t_1	Max 60 s
Time above 230°C (T_2)	t_2	Max 50 s
Time above $T_{peak} - 10^\circ\text{C}$ (T_3)	t_3	Max 10 s
Peak temperature in reflow	T_{peak}	260°C
Temperature gradient in cooling		Max -5°C/s

Figure 44:
Solder Reflow Profile Graph

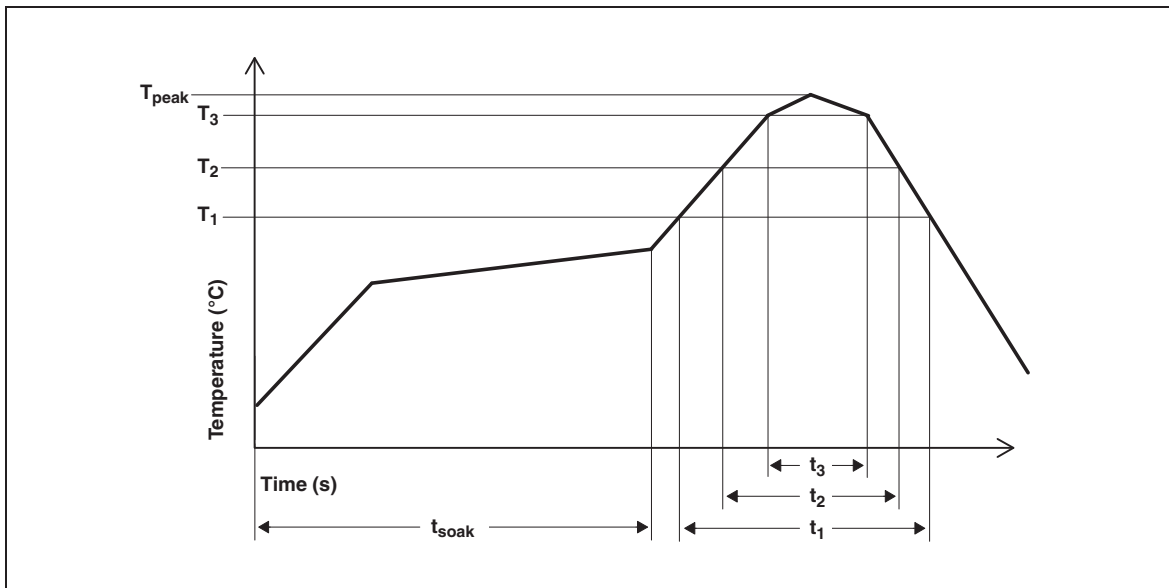

Note(s):

1. Not to scale - for reference only.

Moisture Sensitivity

Optical characteristics of the device can be adversely affected during the soldering process by the release and vaporization of moisture that has been previously absorbed into the package. To ensure the package contains the smallest amount of absorbed moisture possible, each device is dry-baked prior to being packed for shipping. Devices are packed in a sealed aluminized envelope called a moisture barrier bag with silica gel to protect them from ambient moisture during shipping, handling, and storage before use.

The Moisture Barrier Bags should be stored under the following conditions:

- Temperature Range: < 40°C
- Relative Humidity: < 90%
- Total Time: No longer than 12 months from the date code on the aluminized envelope if unopened.

Rebaking of the reel will be required if the devices have been stored unopened for more than 12 months and the Humidity Indicator Card shows the parts to be out of the allowable moisture region.

Opened reels should be used within 168 hours if exposed to the following conditions:

- Temperature Range: < 30°C
- Relative Humidity: < 60%

If rebaking is required, it should be done at 50°C for 12 hours.

The Module has been assigned a moisture sensitivity level of MSL 3.

Ordering & Contact Information

Figure 45:
Ordering Information

Ordering Code	Device	Address	Leads	Interface Description
TMD26711	TMD26711	0x39	8	I ² C Vbus = V _{DD} Interface
TMD26713	TMD26713	0x39	8	I ² C Vbus = 1.8 V Interface

Buy our products or get free samples online at:

www.ams.com/ICdirect

Technical Support is available at:

www.ams.com/Technical-Support

Provide feedback about this document at:

www.ams.com/Document-Feedback

For further information and requests, e-mail us at:

ams_sales@ams.com

For sales offices, distributors and representatives, please visit:

www.ams.com/contact

Headquarters

ams AG
Tobelbaderstrasse 30
8141 Premstaetten
Austria, Europe

Tel: +43 (0) 3136 500 0

Website: www.ams.com

RoHS Compliant & ams Green Statement

RoHS: The term RoHS compliant means that ams AG products fully comply with current RoHS directives. Our semiconductor products do not contain any chemicals for all 6 substance categories, including the requirement that lead not exceed 0.1% by weight in homogeneous materials. Where designed to be soldered at high temperatures, RoHS compliant products are suitable for use in specified lead-free processes.

ams Green (RoHS compliant and no Sb/Br): ams Green defines that in addition to RoHS compliance, our products are free of Bromine (Br) and Antimony (Sb) based flame retardants (Br or Sb do not exceed 0.1% by weight in homogeneous material).

Important Information: The information provided in this statement represents ams AG knowledge and belief as of the date that it is provided. ams AG bases its knowledge and belief on information provided by third parties, and makes no representation or warranty as to the accuracy of such information. Efforts are underway to better integrate information from third parties. ams AG has taken and continues to take reasonable steps to provide representative and accurate information but may not have conducted destructive testing or chemical analysis on incoming materials and chemicals. ams AG and ams AG suppliers consider certain information to be proprietary, and thus CAS numbers and other limited information may not be available for release.

Copyrights & Disclaimer

Copyright ams AG, Tobelbader Strasse 30, 8141 Premstaetten, Austria-Europe. Trademarks Registered. All rights reserved. The material herein may not be reproduced, adapted, merged, translated, stored, or used without the prior written consent of the copyright owner.

Devices sold by ams AG are covered by the warranty and patent indemnification provisions appearing in its General Terms of Trade. ams AG makes no warranty, express, statutory, implied, or by description regarding the information set forth herein. ams AG reserves the right to change specifications and prices at any time and without notice. Therefore, prior to designing this product into a system, it is necessary to check with ams AG for current information. This product is intended for use in commercial applications. Applications requiring extended temperature range, unusual environmental requirements, or high reliability applications, such as military, medical life-support or life-sustaining equipment are specifically not recommended without additional processing by ams AG for each application. This product is provided by ams AG "AS IS" and any express or implied warranties, including, but not limited to the implied warranties of merchantability and fitness for a particular purpose are disclaimed.

ams AG shall not be liable to recipient or any third party for any damages, including but not limited to personal injury, property damage, loss of profits, loss of use, interruption of business or indirect, special, incidental or consequential damages, of any kind, in connection with or arising out of the furnishing, performance or use of the technical data herein. No obligation or liability to recipient or any third party shall arise or flow out of ams AG rendering of technical or other services.

Document Status

Document Status	Product Status	Definition
Product Preview	Pre-Development	Information in this datasheet is based on product ideas in the planning phase of development. All specifications are design goals without any warranty and are subject to change without notice
Preliminary Datasheet	Pre-Production	Information in this datasheet is based on products in the design, validation or qualification phase of development. The performance and parameters shown in this document are preliminary without any warranty and are subject to change without notice
Datasheet	Production	Information in this datasheet is based on products in ramp-up to full production or full production which conform to specifications in accordance with the terms of ams AG standard warranty as given in the General Terms of Trade
Datasheet (discontinued)	Discontinued	Information in this datasheet is based on products which conform to specifications in accordance with the terms of ams AG standard warranty as given in the General Terms of Trade, but these products have been superseded and should not be used for new designs

Revision Information

Changes from TAOS144C (2013-Mar) to current revision 1-00 (2016-May-16)	Page
Content of TAOS datasheet was converted to the latest ams design	
Added Figure 1	2

Note(s):

1. Page and figure numbers for the previous version may differ from page and figure numbers in the current revision
2. Correction of typographical errors is not explicitly mentioned.

Content Guide

1	General Description
2	Key Benefits & Features
2	Applications
3	Block Diagram
4	Detailed Description
5	Pin Assignment
6	Absolute Maximum Ratings
7	Electrical Characteristics
11	Parameter Measurement Information
12	Typical Operating Characteristics
14	Principles of Operation
14	System State Machine
15	Proximity Detection
17	Optical Design Considerations
17	Interrupts
18	State Diagram
19	Power Management
20	I2C Protocol
21	Register Set
22	Command Register
23	Enable Register (0x00)
23	ALS Timing Register (0x01)
24	Proximity Time Control Register (0x02)
24	Wait Time Register (0x03)
25	Proximity Interrupt Threshold Register (0x08 – 0x0B)
25	Persistence Register (0x0C)
26	Configuration Register (0x0D)
26	Proximity Pulse Count Register (0x0E)
27	Control Register (0x0F)
28	ID Register (0x12)
28	Status Register (0x13)
29	Proximity Data Register (0x18 - 0x19h)
30	Application Information: Hardware
30	LED Driver Pin with Proximity Detection
32	PCB Pad Layout
33	Package Drawings & Markings
34	Package Mechanical Data
35	Soldering & Storage Information
36	Moisture Sensitivity
37	Ordering & Contact Information
38	RoHS Compliant & ams Green Statement
39	Copyrights & Disclaimer
40	Document Status
41	Revision Information