

- 1 HOUSING: FLAME RETARDANT, 94V-0 RATED, GLASS FILLED, NYLON OR POLYESTER, COLOR: BLACK  
CONTACTS: PHOS BRONZE.  
INSERTS & SCREWLOCKS: ZINC.
- 2 REFER TO APPLICATION SPEC FOR RECOMMENDED P.C. BOARD MOUNTING DIMENSIONS FOR AUTOMATIC INSERTION.
- 3 CONTACTS: PLATED WITH .000030 MIN GOLD FOR LENGTH OF .055 MIN FROM MATING END, .000100 MIN TIN ON SOLDER END, ALL OVER .000050 MIN NICKEL ON ENTRIE CONTACT.  
INSERTS & SCREWLOCKS: CLEAR CHROMATE COATING.

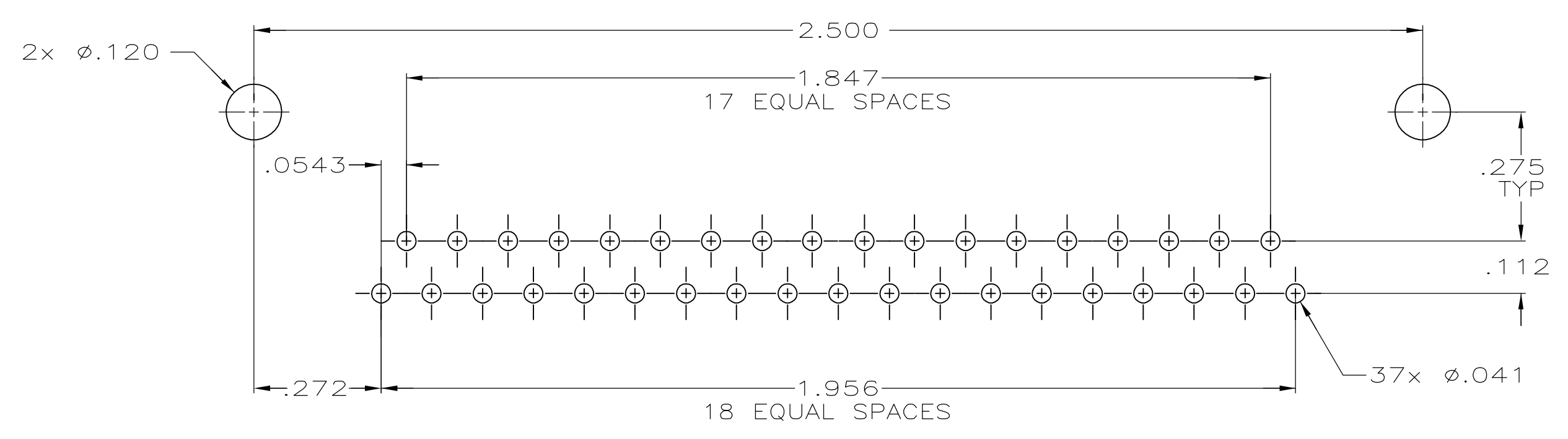
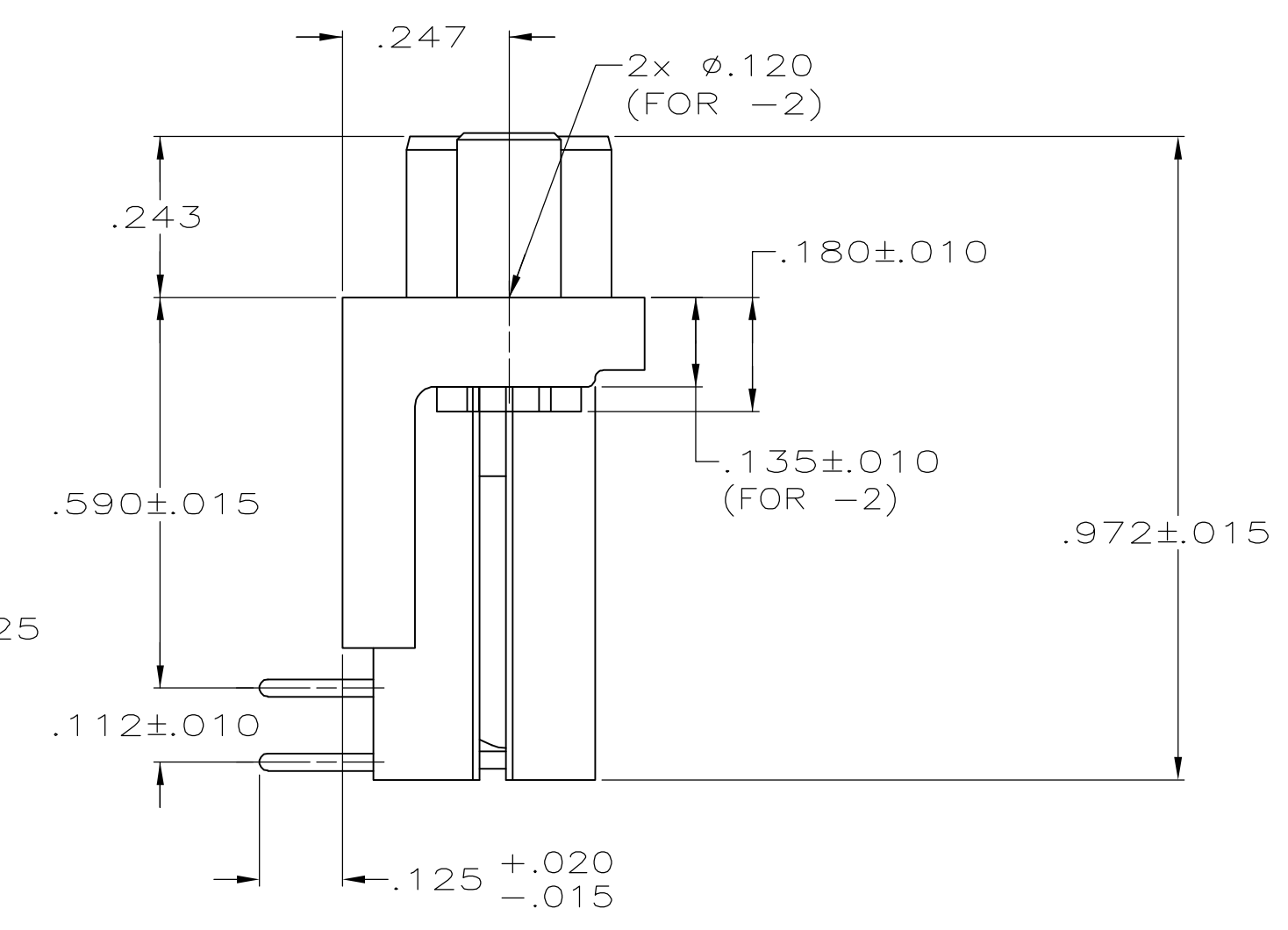
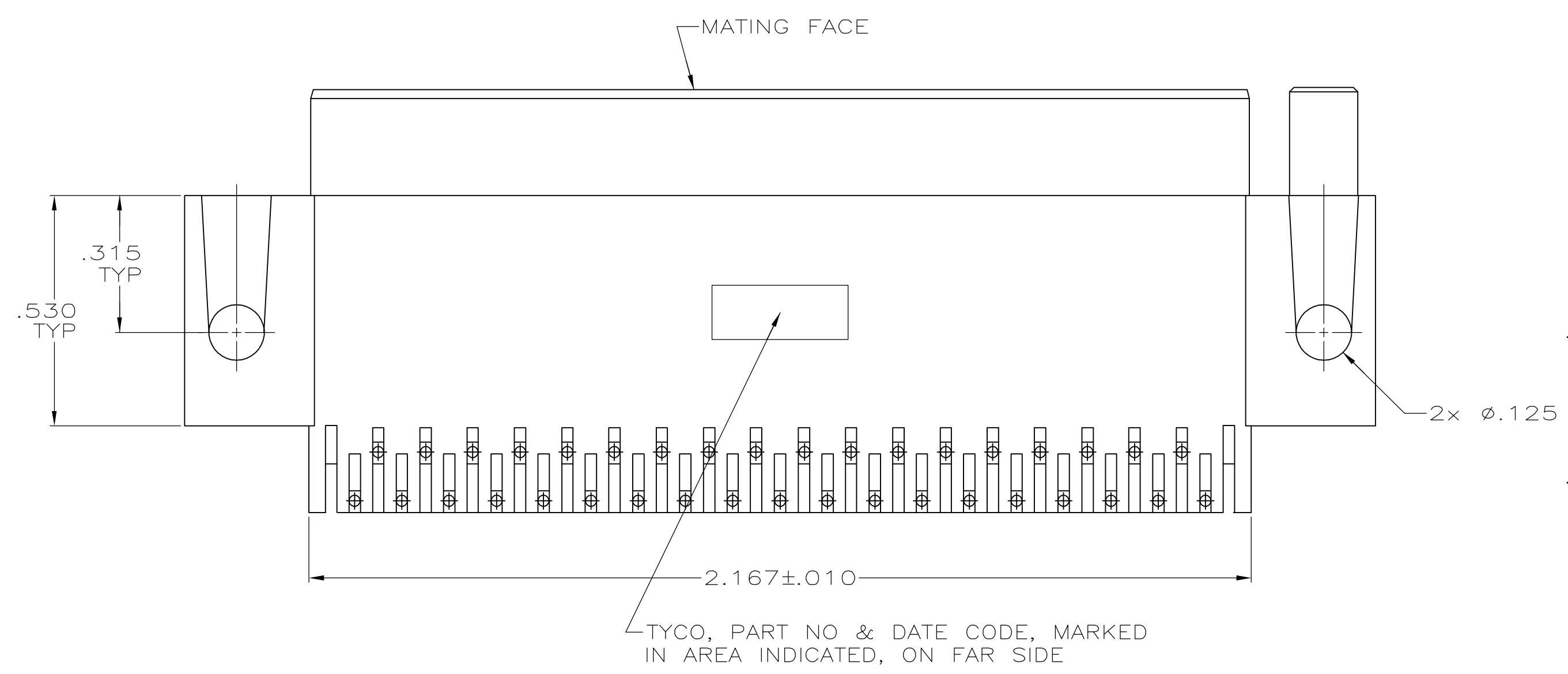

RECOMMENDED P.C. BOARD MOUNTING DIMENSIONS

WITH SCREWLOCKS	5747462-6
WITH INSERTS	5747462-4
WITH .120 DIA HOLE	5747462-2
REMARKS	PART NUMBER

**COPYRIGHT 2005  
 TYCO ELECTRONICS CORP  
 ALL RIGHTS RESERVED**

THIS DRAWING IS A CONTROLLED DOCUMENT.		DWN G. PETERS 16SEP05	Tyco Electronics Corporation Harrisburg, PA 17105-3608	
DIMENSIONS: INCHES		CHK S. BOLASH 16SEP05	APVD M. WALMSLEY 16SEP05	
TOLERANCES UNLESS OTHERWISE SPECIFIED:		NAME RECEPTACLE ASSY, SIZE 4, 37 POSN, RIGHT ANGLE, .590 SERIES, .026 DIA POSTS, AMPLIMITE HD-20		
0 PLC ± - 1 PLC ± - 2 PLC ± - 3 PLC ± .005 4 PLC ± -		PRODUCT SPEC 108-40025		
ANGLES ± z		APPLICATION SPEC 114-40015		
MATERIAL	FINISH	SIZE A1	CAGE CODE 00779	DRAWING NO 5747462
CUSTOMER DRAWING		WEIGHT	RESTRICTED TO	SCALE 4:1
		SHEET 1 OF 1	REV 0	