

# EV-T2HPCC-DC500A-3,0M50ECBK11 - DC charging cable



1148234

<https://www.phoenixcontact.com/us/products/1148234>

Please be informed that the data shown in this PDF document is generated from our online catalog. Please find the complete data in the user documentation. Our general terms of use for downloads are valid.



CHARX connect professional, HPC DC charging cable, with cooled vehicle charging connector and cooled cable, for charging electric vehicles (EV) with direct current (DC), with replaceable mating face frame, with replaceable DC power contacts, without panel feed-through, with digital temperature sensors, HPC CCS type 2, IEC 62196-3-1, 500 A / 1000 V (DC), PHOENIX CONTACT logo, cable: 3 m, black, straight

## Product description

DC charging cable with vehicle charging connector and free cable end for fast charging of electric vehicles (EV) with direct current (DC) via CCS type 2 vehicle charging inlets, for installation at charging stations for e-mobility (EVSE)

## Your advantages

- Complete product range
- The right charging cable for every application, from the carport to the charging park
- Ultra-fast HPC charging, with temporary power up to 500 kW
- Convenient handling due to the ergonomic design
- Available with your logo on request – for consistent branding of your charging station
- Developed and produced in accordance with the IATF 16949 automotive standard and ISO 9001
- Additional safety thanks to integrated leakage sensors and a wear indicator in the cable sheath
- Convenient communication interfaces via CAN bus and digital output
- Maintenance-friendly replacement of the mating face frame without draining the coolant

## Commercial data

Item number	1148234
Packing unit	1 pc
Minimum order quantity	1 pc
Sales key	EM01
Product key	XWBALD
GTIN	4063151140137
Weight per piece (including packing)	16,850 g
Weight per piece (excluding packing)	16,850 g
Customs tariff number	85444290
Country of origin	DE

# EV-T2HPCC-DC500A-3,0M50ECBK11 - DC charging cable



1148234

<https://www.phoenixcontact.com/us/products/1148234>

## Technical data

### Product properties

Product type	DC charging cable
Product family	CHARX connect professional
Application	for charging electric vehicles (EV) with direct current (DC) for installation at charging stations for electromobility (EVSE)
Type	HPC DC charging cable with cooled vehicle charging connector and cooled cable
Design	with replaceable mating face frame with replaceable DC power contacts without panel feed-through with digital temperature sensors
Technology	Combined Charging System High Power Charging
Affixed logo	PHOENIX CONTACT logo
Label	8.9 mm x 28.9 mm (customer logo on request)
Charging standard	HPC CCS type 2
Charging mode	Mode 4

### Cooling system

Cooling	in the vehicle charging connector and in the cable
Coolant	50% water, 50% glycol (Glysofor N)
Cooling capacity	600 W (Cable length: 3 m) 800 W (Cable length: 4 m) 900 W (Cable length: 5 m) 1050 W (Cable length: 6 m)
Cooling hose diameter	1x 11.5 mm Supply hose 2x 8.8 mm Return hoses
Flow rate	2 l/min
Operating pressure	1.00 bar ... 2.00 bar
Relief pressure	2.00 bar
Maximum permissible pressure	4.00 bar
Flow temperature	15 °C
Communication interface	CAN bus for reading the temperature and leakage sensor data Digital output for determining the functional status of the vehicle connector

### Electrical properties

Type of signal transmission	Pulse width modulation with modulated Powerline communication in accordance with ISO/IEC 15118 / DIN SPEC 70121
Note on the connection method	Crimp connection, cannot be disconnected
Coding	1500 Ω (between PE and PP)

# EV-T2HPCC-DC500A-3,0M50ECBK11 - DC charging cable



1148234

<https://www.phoenixcontact.com/us/products/1148234>

Temperature monitoring	2x NTC (replaceable, front DC contacts) 2x NTC (DC power wires inside)
Type of charging current	DC
Charging power	500 kW
Charging current	500 A
Type of charging current	DC Boost Mode
Charging power	up to 700 kW (Boost Mode, depending on the ambient conditions. For detailed information, see the packing slip in the download area for this item.)
Charging current	up to 700 A (Boost Mode, depending on the ambient conditions. For detailed information, see the packing slip in the download area for this item.)

## Power contact

Number	3 (PE, DC+, DC-)
Rated voltage	1000 V DC
Rated current	500 A (up to 40 °C)

## Signal contact

Number	2 (CP, PP)
Rated voltage	30 V AC
Rated current	2 A

## Temperature sensors (NTC)

Sensor type	NTC
Attachment point	2 sensors for the replaceable front DC contacts 2 sensors for the internal DC power wires
Switch-off temperature	90 °C

## Dimensions

### Vehicle charging connector

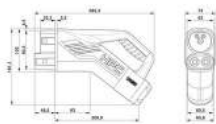
Dimensional drawing	 <p>Make sure that the vehicle charging connector is placed in an appropriate charging connector holder, which ensures a minimum protection rating of IP24 in accordance with IEC 61851-1, for the entire time between charging. To create this charging connector holder, use the dimensions of the vehicle charging connector. Detailed dimensions can also be found in the Download area.</p>
Width	72 mm
Height	181.1 mm
Depth	285.3 mm

## Material specifications

Color (Housing)	black (9005)
-----------------	--------------

# EV-T2HPCC-DC500A-3,0M50ECBK11 - DC charging cable



1148234

<https://www.phoenixcontact.com/us/products/1148234>

Color (Handle area)	black (9005)
Color (Mating face)	black (9005)
Color (Cable)	black (9005)
Material (Vehicle charging connector)	Plastic
Material (Cable outer sheath)	EVM-1 in accordance with EN 50620
Material (Contact surface)	Silver
Flammability rating according to UL 94	V0 (Mating face)

## Cable/line

Cable length	3 m ±45 mm
Wiring standards/regulations	Based on UL 62 (File E515623, Vol 1)
	Based on IEC 62893
Cable weight	max. 1938 kg/km
Cable type	straight
Cable structure	5 x 25 mm <sup>2</sup> + 7 x 0.75 mm <sup>2</sup>
External cable diameter	35.7 mm ±0.4 mm
Outer sheath, material	TPE-U in accordance with IEC 62893-1
Stripping length of the sheath	250 mm ±5 mm
Cable resistance	≤ 0.00078 Ω/m (based on a power core, at an ambient temperature of 20°C)
Bending radius	min. 357 mm (10x diameter)

## Mechanical properties

### Mechanical data

Insertion/withdrawal cycles	> 10000
Insertion force	< 100 N
Withdrawal force	< 100 N

## Environmental and real-life conditions

### Ambient conditions

Degree of protection (Vehicle charging connector)	IP54 (plugged in; when plugged in and ready to operate, the degree of protection is only ensued if both plug-in components are original products from Phoenix Contact or suitable standard-compliant products)
Ambient temperature (operation)	-30 °C ... 40 °C
	max. 55 °C (Current reduction required, observe the DC contact temperature limit value of 90°C)
Ambient temperature (storage/transport)	-40 °C ... 80 °C
Altitude	5000 m (above sea level)

## Standards and regulations

### Standards

Standards/regulations	IEC 62196-3-1
-----------------------	---------------

# EV-T2HPCC-DC500A-3,0M50ECBK11 - DC charging cable



1148234

<https://www.phoenixcontact.com/us/products/1148234>

## Drawings

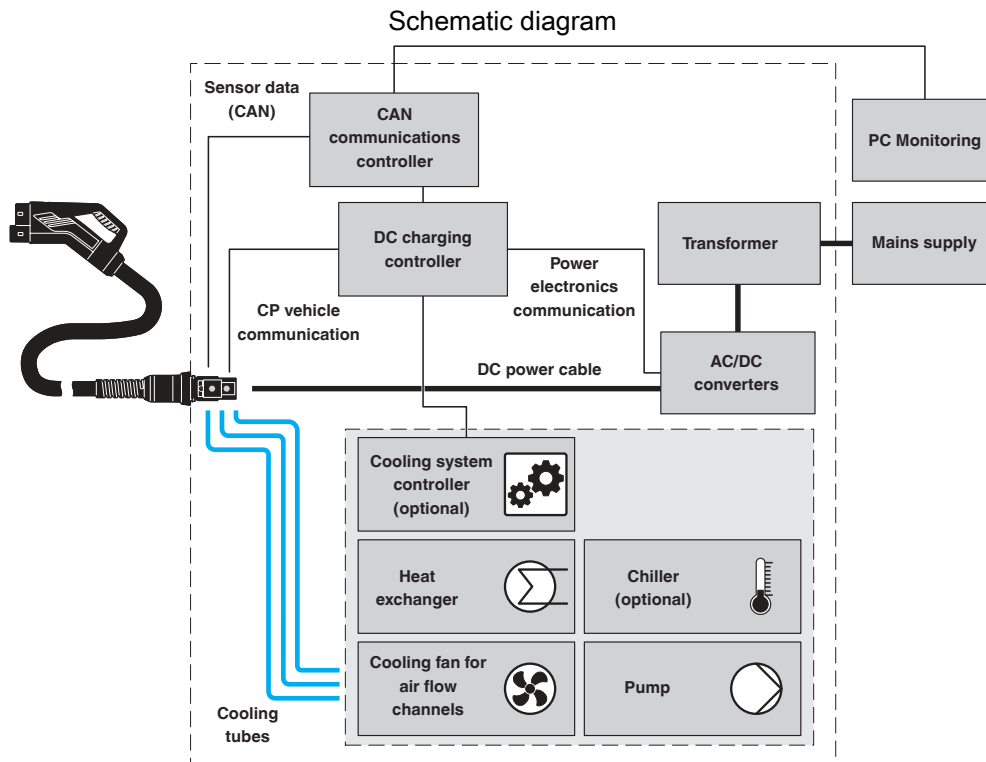

Standalone, decentralized system: cooling unit and controller are integrated into the charging station. The choice of cooling unit can be passive or active (i.e., with or without chiller).

## Dimensional drawing

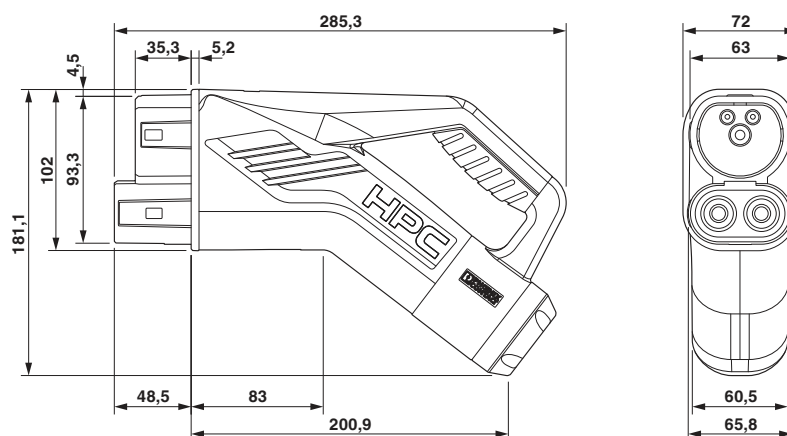

Make sure that the vehicle charging connector is placed in an appropriate charging connector holder, which ensures a minimum protection rating of IP24 in accordance with IEC 61851-1, for the entire time between charging. To create this charging connector holder, use the dimensions of the vehicle charging connector. Detailed dimensions can also be found in the Download area.

# EV-T2HPCC-DC500A-3,0M50ECBK11 - DC charging cable

1148234

<https://www.phoenixcontact.com/us/products/1148234>

Schematic diagram

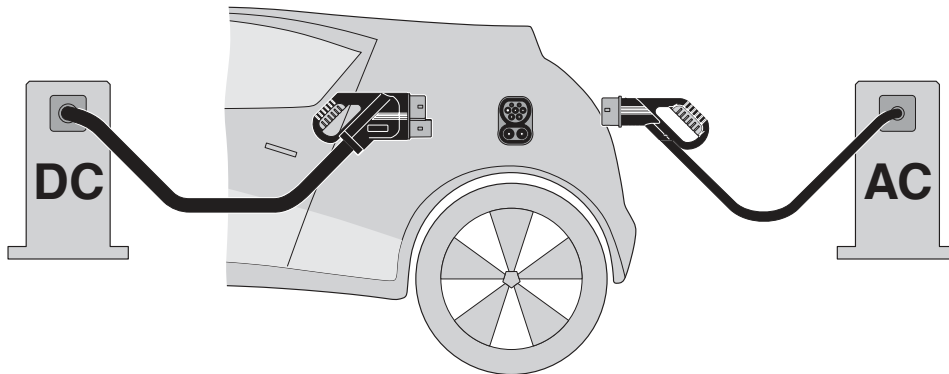

The Combined Charging System (CCS) principle - standard-compliant charging system for electric vehicles, which supports both conventional AC charging and fast DC charging. Both Vehicle Connectors fit into the CCS Vehicle Inlet.

Schematic diagram

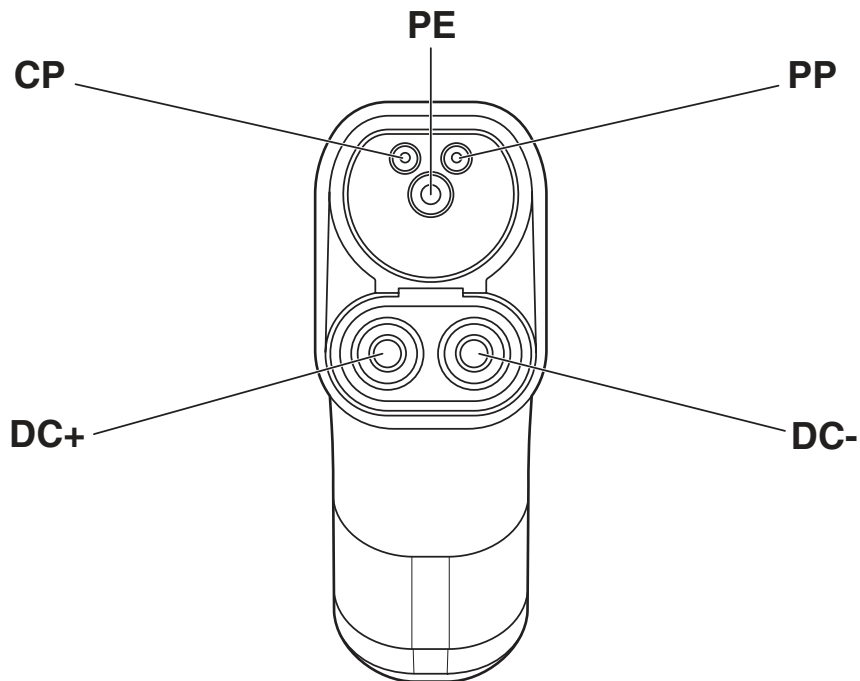

Pin assignment of the Vehicle Connector

# EV-T2HPCC-DC500A-3,0M50ECBK11 - DC charging cable

1148234

<https://www.phoenixcontact.com/us/products/1148234>

Schematic diagram

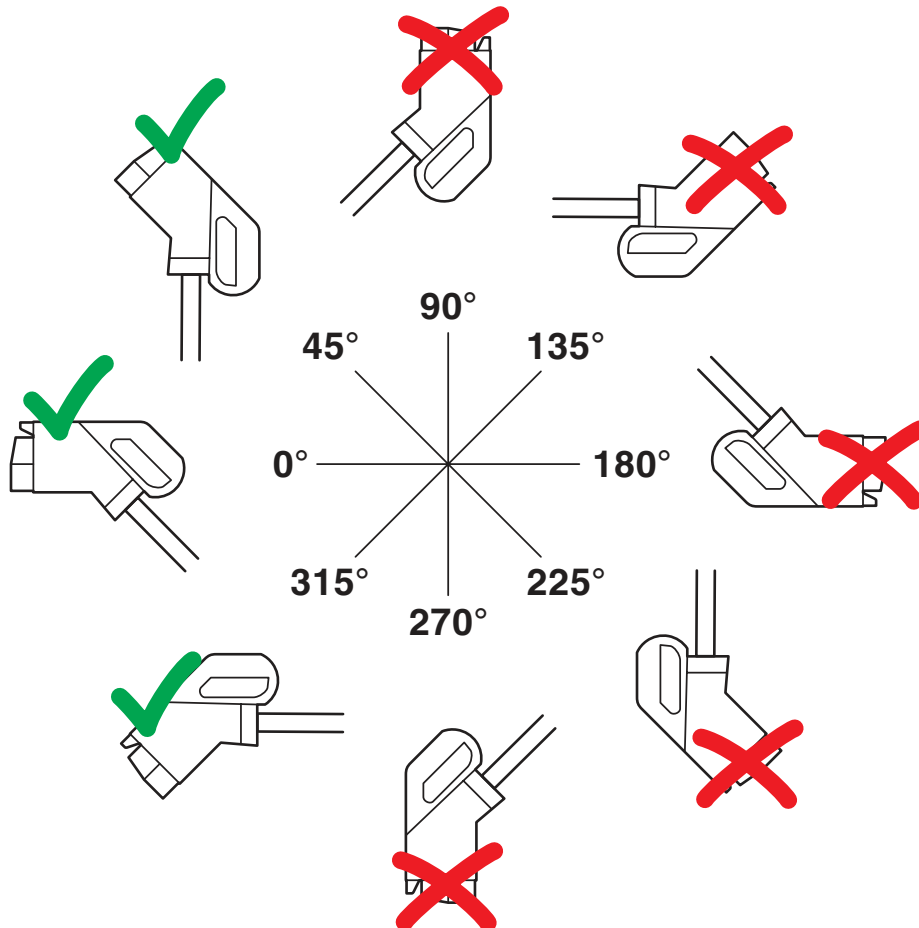

The resting position must be installed in the charging station such that the user cannot hang up the vehicle connector upside down (90° to 270°). However, positions rotated upward (45°) or downward (315°) are options for a resting position.

# EV-T2HPCC-DC500A-3,0M50ECBK11 - DC charging cable

1148234

<https://www.phoenixcontact.com/us/products/1148234>

## Schematic diagram

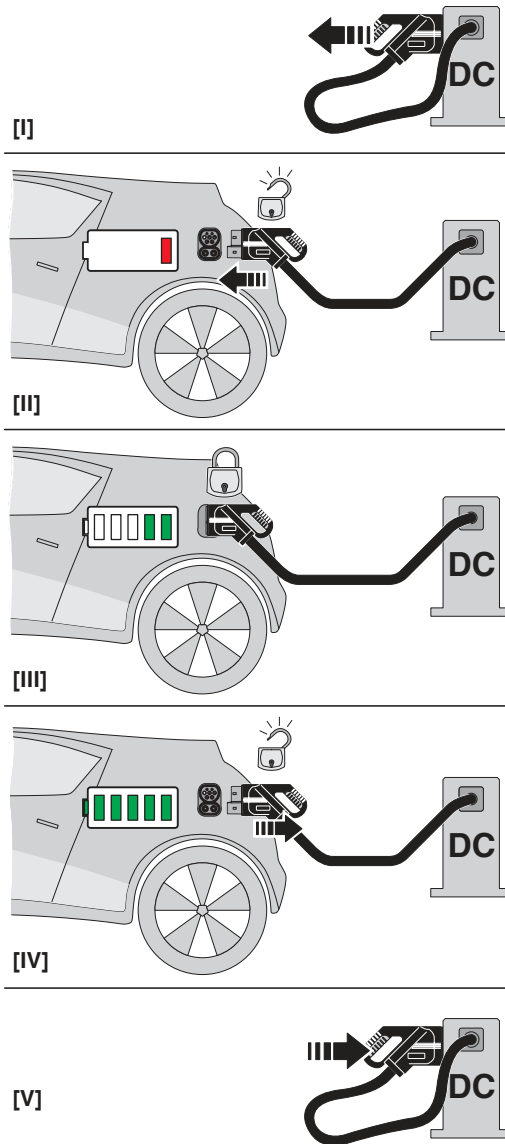

Operating instructions



# EV-T2HPCC-DC500A-3,0M50ECBK11 - DC charging cable

1148234

<https://www.phoenixcontact.com/us/products/1148234>

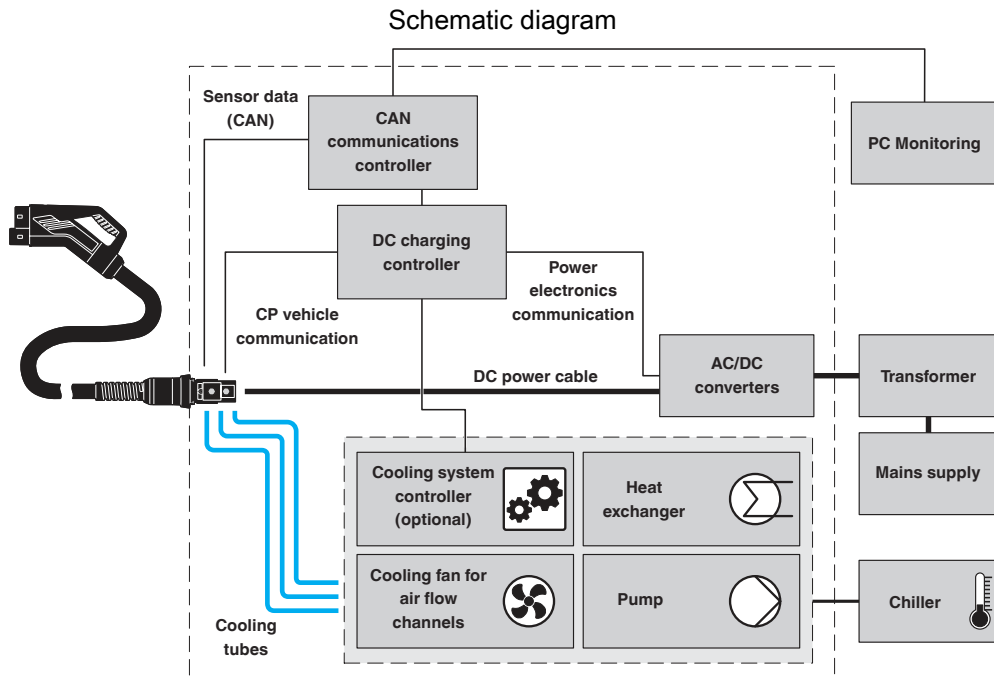

Central system: cooling unit and controller are positioned externally and supply multiple charging stations, each of which is equipped with a heat exchanger. The cooling is done actively using a chiller.

# EV-T2HPCC-DC500A-3,0M50ECBK11 - DC charging cable

1148234

<https://www.phoenixcontact.com/us/products/1148234>

## Schematic diagram

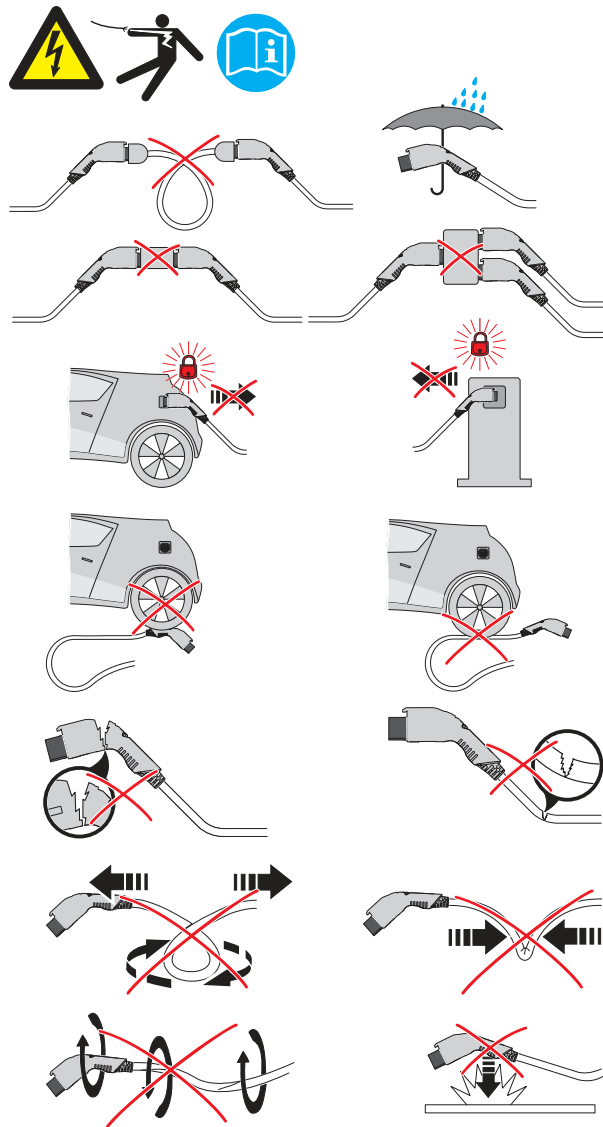

Warning signal note

# EV-T2HPCC-DC500A-3,0M50ECBK11 - DC charging cable



1148234

<https://www.phoenixcontact.com/us/products/1148234>

## Classifications

### ECLASS

ECLASS-11.0	27144705
ECLASS-12.0	27144705
ECLASS-13.0	27144705

### ETIM

ETIM 8.0	EC002897
----------	----------

### UNSPSC

UNSPSC 21.0	39121500
-------------	----------

# EV-T2HPCC-DC500A-3,0M50ECBK11 - DC charging cable



1148234

<https://www.phoenixcontact.com/us/products/1148234>

## Environmental product compliance

REACH SVHC	Lead 7439-92-1
China RoHS	Environmentally Friendly Use Period = 10;
	For information on hazardous substances, refer to the manufacturer's declaration available under "Downloads"

# EV-T2HPCC-DC500A-3,0M50ECBK11 - DC charging cable



1148234

<https://www.phoenixcontact.com/us/products/1148234>

## Accessories

### EV-T2CCS-MF-M4X10-BIT-CTS - Repair kit

1085799

<https://www.phoenixcontact.com/us/products/1085799>



CHARX connect, Repair kit, Accessories, with DC contact holder with integrated front part of the DC contacts, with replaceable mating face frame, with 5x M4X10 rounded head screws with Torx security drive, with special bit for insulated screwdriver, for replacement of the mating face frame of vehicle charging connectors, HPC CCS type 2, IEC 62196-3-1, housing: black, Replacement without draining the coolant

---

### EV-T2CCS-MF-M4X10-CTS - Repair kit

1281249

<https://www.phoenixcontact.com/us/products/1281249>



CHARX connect, Repair kit, Accessories, with DC contact holder with integrated front part of the DC contacts, with replaceable mating face frame, with 5x M4X10 rounded head screws with Torx security drive, for replacement of the mating face frame of vehicle charging connectors, HPC CCS type 2, IEC 62196-3-1, housing: black, Replacement without draining the coolant

# EV-T2HPCC-DC500A-3,0M50ECBK11 - DC charging cable



1148234

<https://www.phoenixcontact.com/us/products/1148234>

## EV-T2CCS-MF-M4X10-BIT - Repair kit

1085798

<https://www.phoenixcontact.com/us/products/1085798>



CHARX connect, Repair kit, Accessories, with replaceable mating face frame, with 5x M4X10 rounded head screws with Torx security drive, with special bit for insulated screwdriver, for replacement of the mating face frame of vehicle charging connectors, HPC CCS type 2, IEC 62196-3-1, housing: black, Replacement without draining the coolant

---

## EV-T2CCS-MF-M4X10 - Repair kit

1085797

<https://www.phoenixcontact.com/us/products/1085797>



CHARX connect, Repair kit, Accessories, with replaceable mating face frame, with 5x M4X10 rounded head screws with Torx security drive, for replacement of the mating face frame of vehicle charging connectors, HPC CCS type 2, IEC 62196-3-1, housing: black, Replacement without draining the coolant

# EV-T2HPCC-DC500A-3,0M50ECBK11 - DC charging cable



1148234

<https://www.phoenixcontact.com/us/products/1148234>

## EV-T2CCS-M4X20-BIT-CTS - Repair kit

1295670

<https://www.phoenixcontact.com/us/products/1295670>



CHARX connect, Repair kit, Accessories, with DC contact holder with integrated front part of the DC contacts, with special bit for insulated screwdriver, HPC CCS type 2, IEC 62196-3-1, housing: black, Replacement without draining the coolant

---

## EV-T2CCS-M4X20-CTS - Repair kit

1295577

<https://www.phoenixcontact.com/us/products/1295577>



CHARX connect, Repair kit, Accessories, with DC contact holder with integrated front part of the DC contacts, HPC CCS type 2, IEC 62196-3-1, housing: black, Replacement without draining the coolant

# EV-T2HPCC-DC500A-3,0M50ECBK11 - DC charging cable



1148234

<https://www.phoenixcontact.com/us/products/1148234>

## EV-GRIP-D35,7MM - Cable handle

1091431

<https://www.phoenixcontact.com/us/products/1091431>



CHARX connect, Cable handle, Accessories, For vehicle charging connector, HPC CCS type 2, HPC CCS type 1, IEC 62196-3-1, housing: black, Please note: The item can only be used with the outer cable diameter indicated.

---

## G-INS-M63-L68L-PNES-BK - Cable gland

1411139

<https://www.phoenixcontact.com/us/products/1411139>



Cable gland, material for screw connection: PA, external cable diameter 34 mm .  
.. 44 mm, shielding: no, connecting thread: M63 x 1.5, color: jet black RAL 9005



# EV-T2HPCC-DC500A-3,0M50ECBK11 - DC charging cable



1148234

<https://www.phoenixcontact.com/us/products/1148234>

## EV-HPC-PCU-01 - Cooling unit

1237881

<https://www.phoenixcontact.com/us/products/1237881>



CHARX connect, Cooling unit, Accessories, with variable-speed fan, with variable-speed pump, for cooling the cooling liquid of a Phoenix Contact HPC DC charging cable, HPC CCS type 2, HPC CCS type 1, length: 1.5 m

---

## EV-HPC-QC - Quick coupling

1346562

<https://www.phoenixcontact.com/us/products/1346562>



CHARX connect, Quick coupling, Accessories, Counterpart for connecting the coolant lines of a PHOENIX CONTACT HPC DC charging cable, HPC CCS type 2, HPC CCS type 1

# EV-T2HPCC-DC500A-3,0M50ECBK11 - DC charging cable



1148234

<https://www.phoenixcontact.com/us/products/1148234>

## EV-LABEL-K - Label

1309761

<https://www.phoenixcontact.com/us/products/1309761>

CHARX connect, Label, Accessories, for CCS type 2 vehicle charging connector, DIN EN 17186, adhesive



---

## EV-LABEL-L - Label

1309765

<https://www.phoenixcontact.com/us/products/1309765>

CHARX connect, Label, Accessories, for CCS type 2 vehicle charging connector, DIN EN 17186, adhesive



# EV-T2HPCC-DC500A-3,0M50ECBK11 - DC charging cable



1148234

<https://www.phoenixcontact.com/us/products/1148234>

## CHARX PS/3AC/920DC/87.5KW - DC power module

1162690

<https://www.phoenixcontact.com/us/products/1162690>



CHARX power basic, Fast charging module for setting up DC charging stations, Rack mounting, input: 3-phase, output: 200 V DC...920 V DC / 125 A. The corresponding system control cabinet CHARX PS-CAB/4x87.5KW (Item No. 1165442) is necessary for operating the DC power module

---

## CHARX PS-M2/3AC/1000DC/30KW - DC power module

1232243

<https://www.phoenixcontact.com/us/products/1232243>



CHARX power basic, Fast charging module for setting up DC charging stations, 19" rack mounting, CAN bus, input: 3-phase, output: 150 V DC...1000 V DC / 0 A...100 A

# EV-T2HPCC-DC500A-3,0M50ECBK11 - DC charging cable



1148234

<https://www.phoenixcontact.com/us/products/1148234>

## CHARX PS-M2/825DC/1000DC/30KW - DC power module

1296467

<https://www.phoenixcontact.com/us/products/1296467>

CHARX power basic, Fast charging module for setting up DC charging stations, 19" rack mounting, CAN bus, output: 150 V DC...1000 V DC / 0 A...100 A



---

Phoenix Contact 2023 © - all rights reserved

<https://www.phoenixcontact.com>

Phoenix Contact USA  
586 Fulling Mill Road  
Middletown, PA 17057, United States  
(+717) 944-1300  
[info@phoenixcon.com](mailto:info@phoenixcon.com)