

THIS DRAWING IS UNPUBLISHED. RELEASED FOR PUBLICATION
 © COPYRIGHT BY TYCO ELECTRONICS CORPORATION. ALL RIGHTS RESERVED.

LOC	DIST	REVISIONS			
P	LTR	DESCRIPTION	DATE	DWN	APVD
AF	14				
	C1	REV PER ECR 05-002915	25MAY05	JR	KR

D

C

B

A

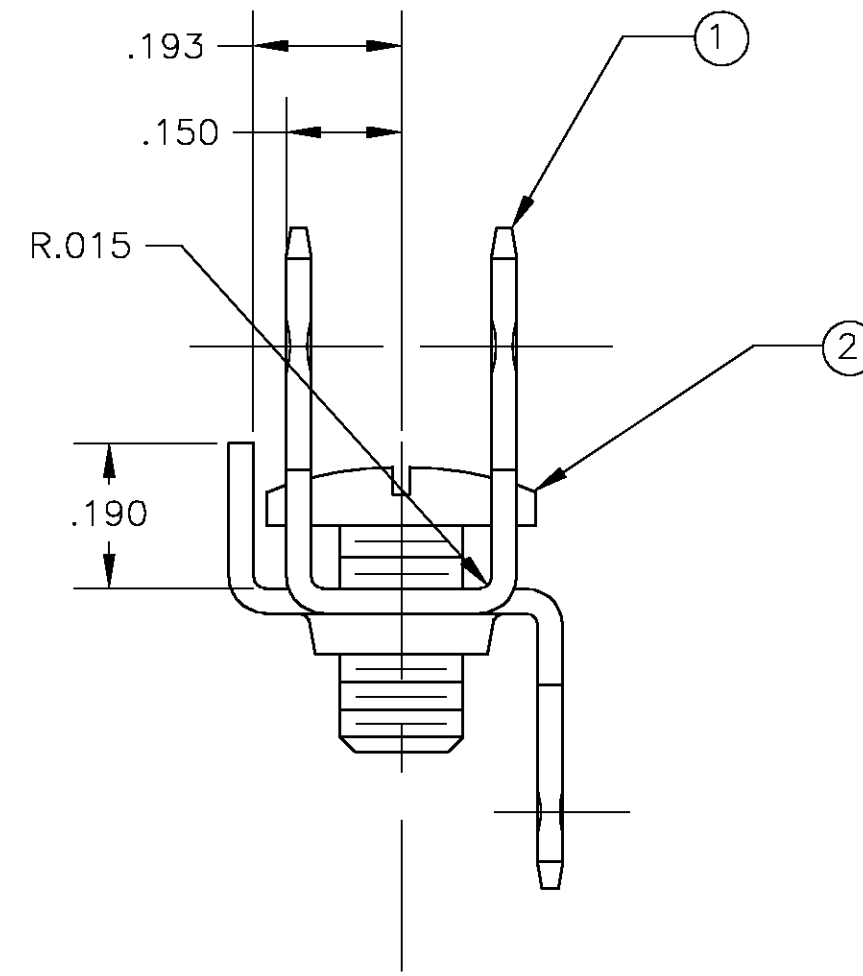
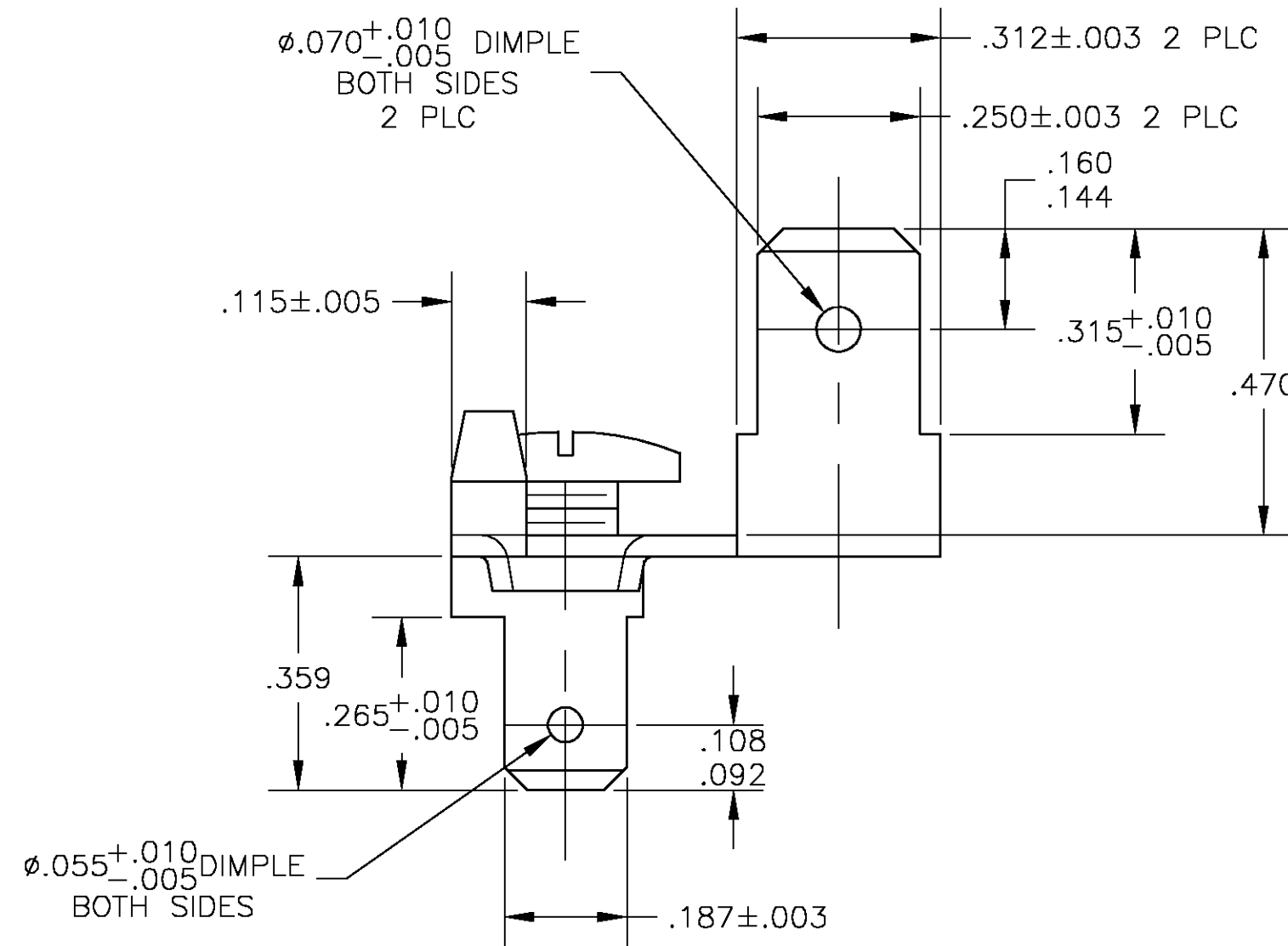
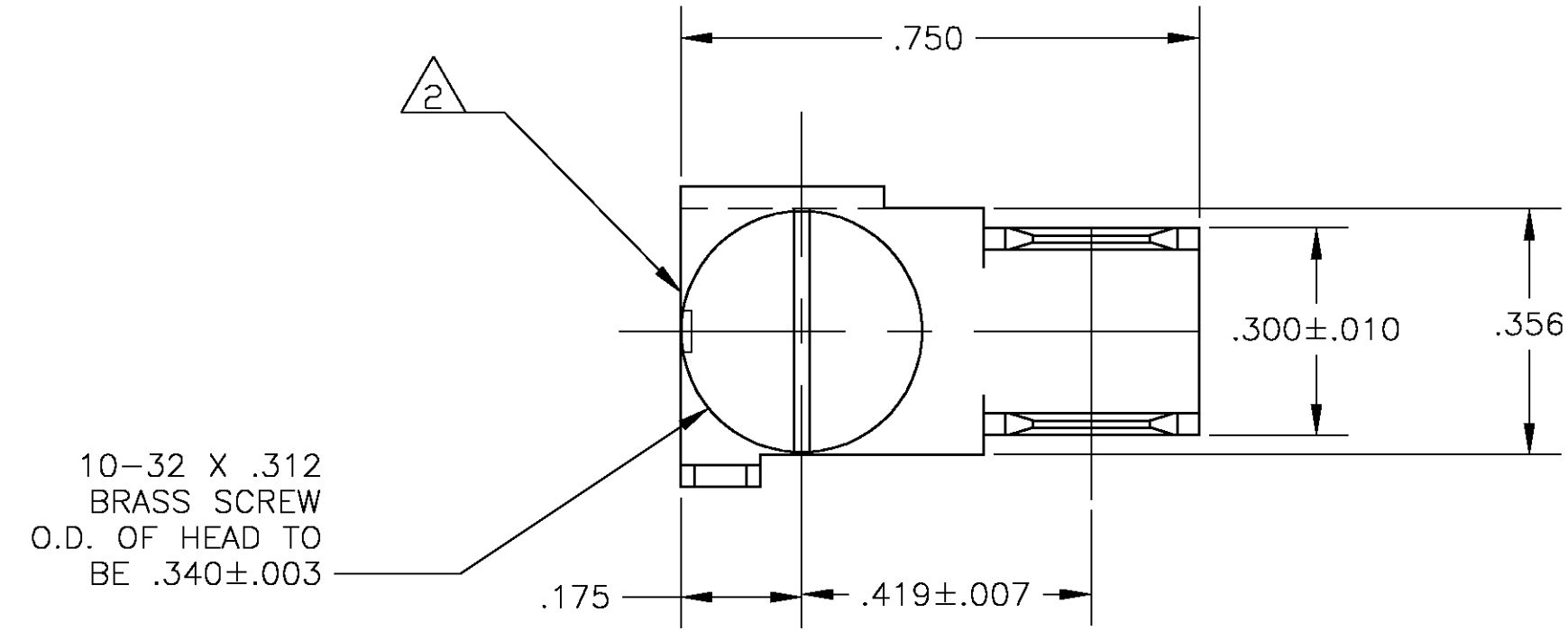

- 1 MATERIAL: .032±.001 THK BRASS, 100-86, HEAT TREAT 0.082
- 2 .010 MAX CUT-OFF ALLOWED
- 3 ASSEMBLY SCREW AND TORQUE 2-8 LB-IN
- 4 THREADS DEFORMED SO AS NOT TO ALLOW REMOVAL OF THE SCREW.
- 5 PART TO BE CLEAN AND OIL FREE
- 6 MATERIAL: BINDING HEAD .340 DIA, #10-32 .312 LONG. BRASS SCREW (ELECTRICAL TAPE)
- 7 MATERIAL: BINDING HEAD .340 DIA, #10-32 .312 LONG. BRASS SCREW (ELECTRICAL TAPE) BRIGHT NICKEL FINISH

D

C

B

A

1	7	-	1	1	T20737542	FASTON TAB ASSEMBLY NICKEL PLATED BRASS SCREW	157727-2
-	1	6	1	1	T20737542	FASTON TAB ASSEMBLY BRASS SCREW	157727-1
SCREW 157423-2	(e)	SCREW 157423-1	(e)	FASTON TAB 157728-1	(1)	EMERSON P/N	DESCRIPTION
							PART NO.

THIS DRAWING IS A CONTROLLED DOCUMENT.

DWN	JR RUTH	25MAY05	 Tyco Electronics Corporation Harrisburg, Pa 17105-3608			
CHK	K RANDOLPH	26MAY05				
APVD	K RANDOLPH	26MAY05				
NAME	ASSEMBLY, TAB, FASTON, .250 AND 187 SERIES					
DIMENSIONS: INCHES	TOLERANCES UNLESS OTHERWISE SPECIFIED:	PRODUCT SPEC	SIZE	CAGE CODE	DRAWING NO	RESTRICTED TO
0 PLC ± -	1 PLC ± -	APPLICATION SPEC	A2	00779	C=157727	-
1 PLC ± -	2 PLC ± -	WEIGHT	CUSTOMER DRAWING		SCALE	SHEET
2 PLC ± -	3 PLC ± .005	FINISH	4:1	1	1	REV
3 PLC ± -	4 PLC ± -					C1
4 PLC ± -	ANGLES ± 1'					

157727