

PHOTONIC DETECTORS INC.

Silicon Photodiode, U.V. Enhanced Photoconductive Type PDU-C114-Q

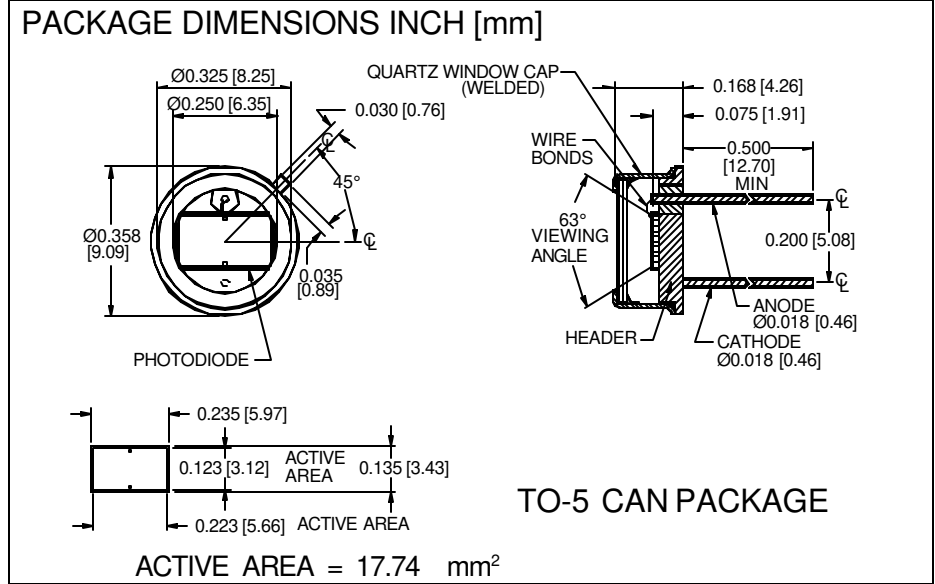

FEATURES

- High speed
- U.V. enhanced
- Low capacitance
- Quartz window

DESCRIPTION

The **PDU-C114-Q** is a silicon, PIN planar diffused, U.V. enhanced photodiode. Ideal for high speed photoconductive applications. Packaged in a TO-5 metal can with a flat quartz window.

APPLICATIONS

- Spectrometers
- Fluorescent analysers
- U.V. meters
- Colorimeters

ABSOLUTE MAXIMUM RATING (TA=25°C unless otherwise noted)

SYMBOL	PARAMETER	MIN	MAX	UNITS
V _{BR}	Reverse Voltage		30	V
T _{STG}	Storage Temperature	-55	+150	°C
T _O	Operating Temperature Range	-40	+125	°C
T _S	Soldering Temperature*		+240	°C
I _L	Light Current		500	mA

*1/16 inch from case for 3 secs max

SPECTRAL RESPONSE

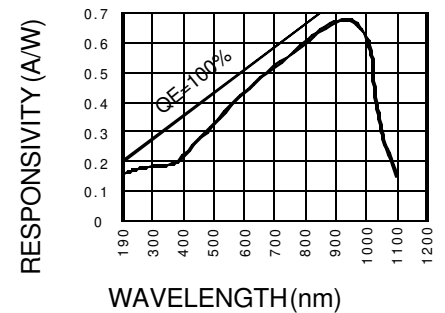

ELECTRO-OPTICAL CHARACTERISTICS (TA=25°C unless otherwise noted)

SYMBOL	CHARACTERISTIC	TEST CONDITIONS	MIN	TYP	MAX	UNITS
I _{SC}	Short Circuit Current	H = 100 fc, 2850 K	190	235		μA
I _D	Dark Current	H = 0, V _R = 5 V		3	8	nA
R _{SH}	Shunt Resistance	H = 0, V _R = 10 mV	75	250		MΩ
TC R _{SH}	RSH Temp. Coefficient	H = 0, V _R = 10 mV		-8		% / °C
C _J	Junction Capacitance	H = 0, V _R = 5 V**		200		pF
λ _{range}	Spectral Application Range	Spot Scan	190		1100	nm
R	Responsivity	V _R = 0 V, λ = 254 nm	.12	.18		A/W
V _{BR}	Breakdown Voltage	I = 10 μA	15	25		V
NEP	Noise Equivalent Power	V _R = 10 mV @ Peak		3.8x10 ⁻¹⁴		W/√Hz
tr	Response Time	RL = 1 KΩ V _R = 5 V		65		nS

Information in this technical data sheet is believed to be correct and reliable. However, no responsibility is assumed for possible inaccuracies or omission. Specifications are subject to change without notice. **f=1 MHz

[FORM NO. 100-PDU-C114-Q REV N/C]