

ADA compliant, tactile keypad for audible system navigation



Storm Assistive Technology Products provide improved accessibility for those with impaired vision, restricted mobility or limited fine motor skills.

Kiosks, ATMs, ticketing machines and voting terminals usually present information about available products and services via a visual display or touch screen. Nav-Pad™ is a highly tactile interface that improves accessibility, making navigation and selection of screen based menus possible for those with impaired vision or restricted movement. Nav-Pad™ is available as a non-encoded switch matrix version or as an encoded USB compatible device.

Nav-Pad™ was developed in association with the Trace Research & Development Center with support from the University of Wisconsin. Nav-Pad™ is a compliant tactile interface device for use as part of an ADA audible menu navigation system or EZ-Access® implementation.

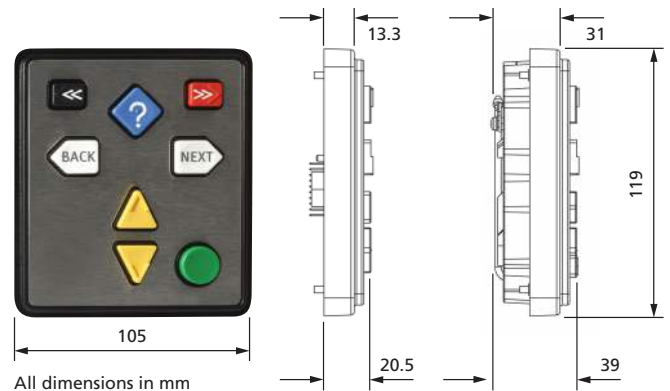

- Available in standard 5 key, and 8 key configurations to suit most applications.
- Available as a non-encoded switch matrix terminated via a male, goldplated, square pin, 0.1" (2.54mm) pitch connector with locking ramp.
- Also available as an encoded USB compatible device, supplied with an attached 'hard-wired' 2.5m USB cable.
- Weather resistant.
- Keypad colours, shapes and tactile symbols make them readily identifiable by both sight and touch.

Storm, Storm ATP, Storm Interface, Nav-Pad and Audio-Module are trademarks of Keymat Technology Ltd. All rights reserved. EZ Access® is a trademark of the Wisconsin Alumni Research Foundation.



RETAIL

Environmental

Vibration & Shock:
Impact Resistance:
Operational temperature:
Weather Resistance:

ETSI 6M3
IK09 (10J Rating)
-20°C to +70°C (dry)
IP65 (when panel mounted)



CORPORATE

Performance

Operational Key Life:
Certification:

>4 million cycles per key
CE / FCC / UL



CIVIC

Specification

Rating:
Connection:
Panel Cutout

5V ± 0.25V (USB 2.0)
Mini USB B Socket
109.5mm x 95.5mm
5mm Radius Corners
1.2 – 2mm panel thickness (recommended)

Underpanel Seal

Included



Nav-Pad™ Keypads



8 Key Layout



5 Key Layout

Storm Nav-Pad™ keypads are constructed to survive in exposed or hostile outdoor environments the keypads will withstand heavy use and abuse. They are sealed against the ingress of liquids and dust to survive regular wash down and sanitation procedures. Nav-Pad™ keypads feature an optional integral USB interface to ensure hassle free, single cable connection to the host system. (Please note: The USB cable is supplied 'hard-wired').

CONTACT MATRIX AS SEEN FROM REAR

PIN	ROW / COLUMN
10	NOT USED
9	R3
8	R4
7	NOT USED
6	C3
5	C2
4	C1
3	R2
2	R1
1	NOT USED

OUTPUTS - MATRIX & USB VERSIONS

MATRIX (Row/Column)	LEGEND	KEY COLOR	USB (Keycode)	Description
R1C1	<<	BLACK	F23	Home/Menu
R1C2	?	BLUE	F17	EZ-Help
R1C3	>>	RED	F24	End
R2C1	BACK	WHITE	F21	Back
R2C3	NEXT	WHITE	F22	Next
R3C2		YELLOW	F18	Up
R4C2		YELLOW	F19	Down
R4C3		GREEN	F20	Action

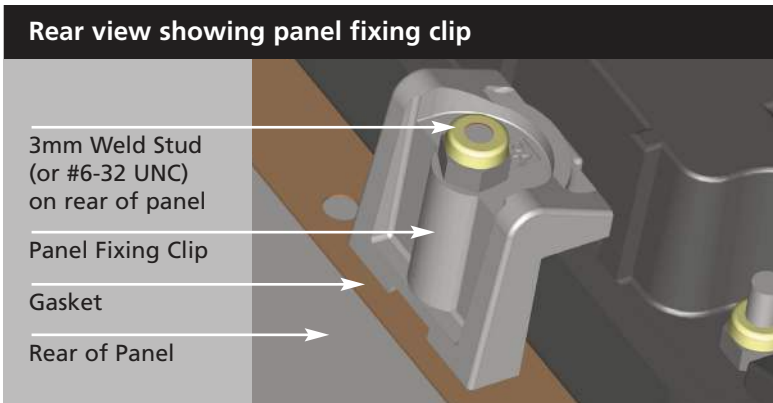

Nav-Pad™ Keypad Range	Part Numbers
8 Key format, USB Interface	EZ08-22201
5 Key format, USB Interface	EZ05-22201
8 Key format, Switch Matrix	EZ08-21001
5 Key format, Switch Matrix	EZ05-21001

Accessories	Part Number
• Set of Fixing Clips	6000-MK00

Whilst every effort is made to ensure details are correct at time of print, specifications are subject to change without notice.



For more information & to order:
www.storm-interface.com

Storm Interface products include technology protected by international patents and design registration. All rights reserved. Storm is a trademark of Keymat Technology Ltd. Storm Interface is a trading name of Keymat Technology Ltd.

Nav-Pad Classic Dec 2016
 Designed & produced by NIK Design Ltd
www.nikdesign.co.uk



FM 39602

