

# Designer's Guide to the ISL95813 Evaluation Board

## Description

The ISL95813 single-phase controller provides a fully compliant VR12.6 power supply solution for Intel™ microprocessors. It provides a tightly regulated output voltage that is programmed through a high speed serial bus interface with the CPU. This interface also allows the CPU to acquire real-time information from the voltage regulator (VR), which includes load current and VR temperature.

Based on Intersil's Robust Ripple Regulator (R3™) technology, the PWM modulator provides faster transient response and settling time when compared against traditional modulation schemes. Its variable frequency topology also allows for natural period stretching discontinuous conduction mode (DCM) for increased efficiency and power savings in light load situations.

The ISL95813 has several other key features that include: DCR current sensing with single NTC thermal compensation; discrete resistor current sensing; differential remote voltage feedback; and user-programmable boot voltage,  $I_{MAX}$ ,  $T_{MAX}$ , voltage transition slew rate, and switching frequency.

## What's Inside

The Evaluation Board Kit contains the following documents:

- ISL95813EV1Z Rev C Board
- [ISL95813](#) datasheet
- AN1846 (this document)

## What's Needed

The following materials will be needed to perform testing on the ISL95813:

- 5V, 3A power supply
- Adjustable 20A Power Supply (Up to 20V)
- 12V, 3A power supply (optional, used with on-board load generator)
- Electronic load
- 4-channel oscilloscope
- Precision multi-meter
- Gen 4 Intel VT Tool
  - To use the SVID emulator hardware and software instead of the VT Tool, resistors R10, R12, and R16 must be depopulated

## Startup Procedure

1. Set the 5V supply to 5V and keeping the output off, connect the (+) end to P1 and the (-) end to P4.
2. Set the second supply to the desired input voltage (4.6V-19V) and with the output off, connect the (+) end to J9 and the (-) end to J12.
3. If using the on-board load generator set the third supply to 12V and with the output off, connect the (+) end to P2 and the (-) end to P3.
4. Ensure jumpers J1, J17, and J19 are shorted. S1 and S2 should be in the OFF position.
5. If using Intel's test tool, plug the interposer and tool into the CPU socket.
6. Turn on the 5V supply and then the  $V_{IN}$  supply.
7. Plug in the power cable to the VT Tool if in place.
8. Finally, if using the on board transient generator power on the 12V supply.
9. Flip S1 to the ON position. D1 should change from RED to GREEN.
10. Measure  $V_{OUT}$  with a multi-meter from TP9 (+) to TP10 (-). It should read  $1.7V \pm 8.5mV$ . If using the VT Tool measure  $V_{OUT}$  across TP29 (+) and TP28 (-).
11. Validation and testing of the ISL95813 can now begin.

## Using the On-Board Transient Generator

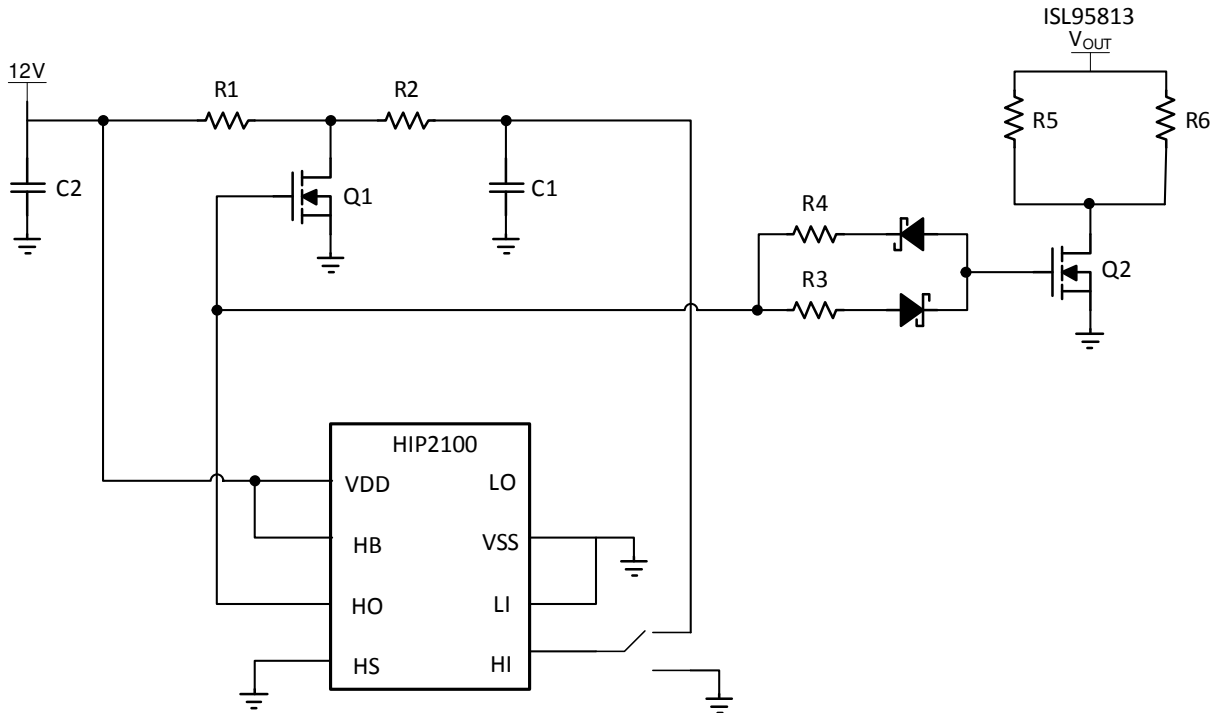
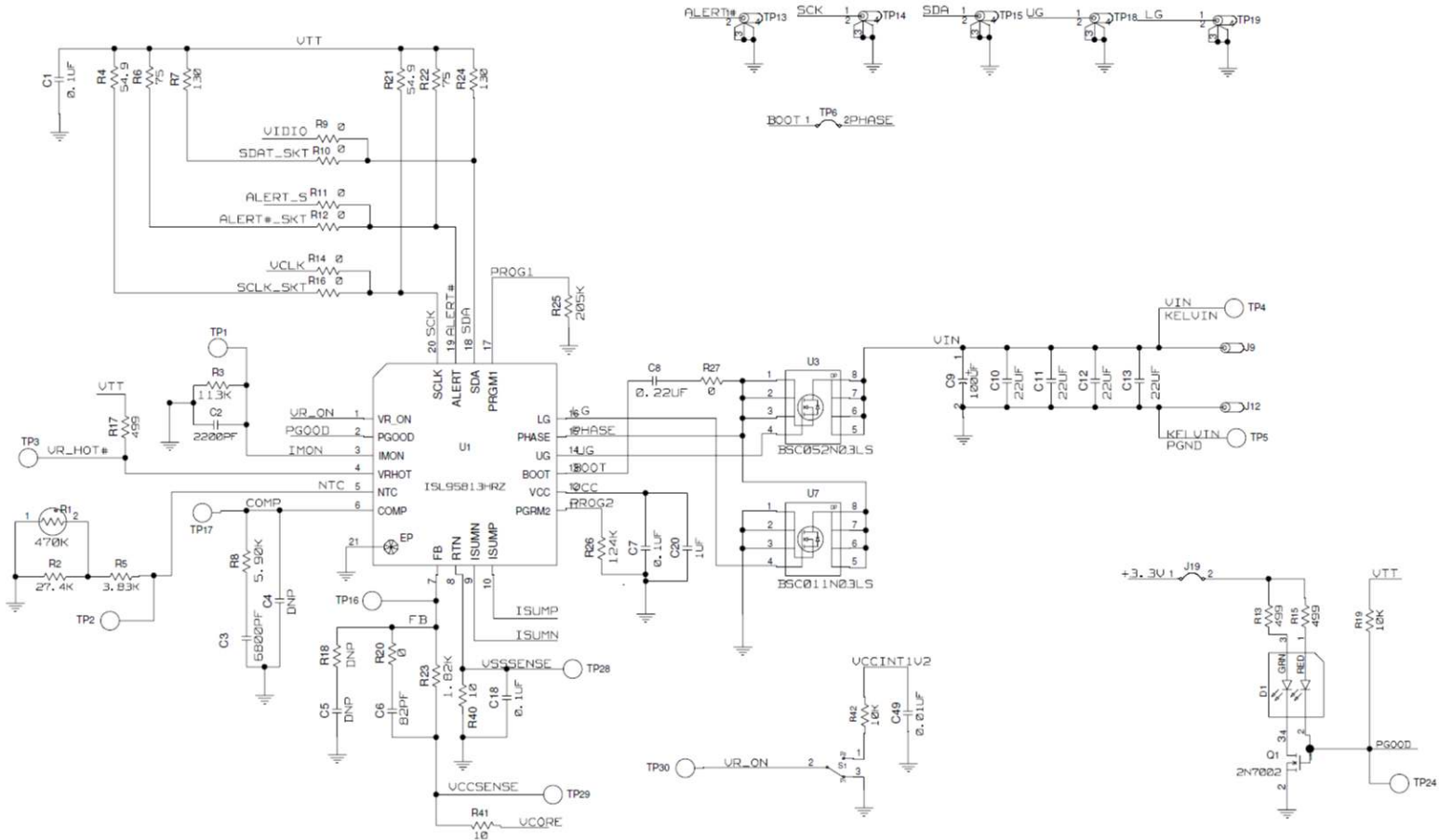

FIGURE 1. EVALUATION BOARD TRANSIENT GENERATOR

- When HI is switched to GND (turn off transient generator):
  - HO go low
  - Q1 turns off
  - Assuming Q2 is initially on, it will then shut off
  - C1 charges to 12V
- When HI is switched to C1:
  - HO goes hi
  - Q1 turns on and C1 discharges through R2
  - Q2 turns on and pulls current from V<sub>OUT</sub> (Load Step)
  - When C1 discharges enough HI switches low and HO goes low too
  - Q1 and Q2 turn off (Load Release)
  - C1 charges through R1+R2 until HI switches HI again and the cycle repeats
- Setting Parameters:
  - $\tau_{ON} = C1 \times R2$
  - $\tau_{OFF} = C1 \times R1 \times R2$
  - $I_{LOAD} = \frac{V_{OUT}}{R5 \parallel R6}$
  - R3 controls the slope of the Load Step
  - R4 controls the slope of the Load Release

# Evaluation Board Schematic





Evaluation Board Schematic (Continued)

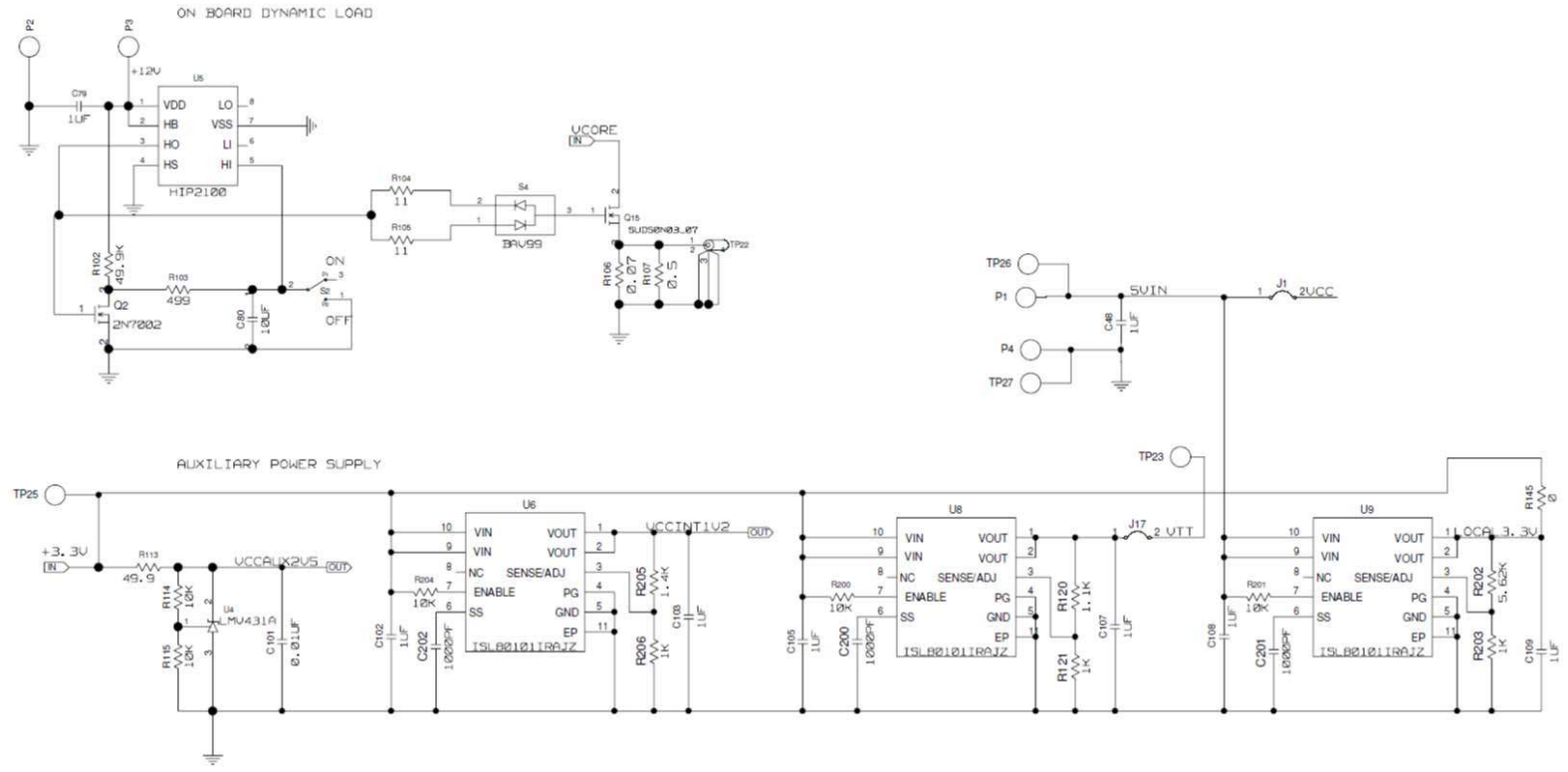

# Evaluation Board Schematic (Continued)

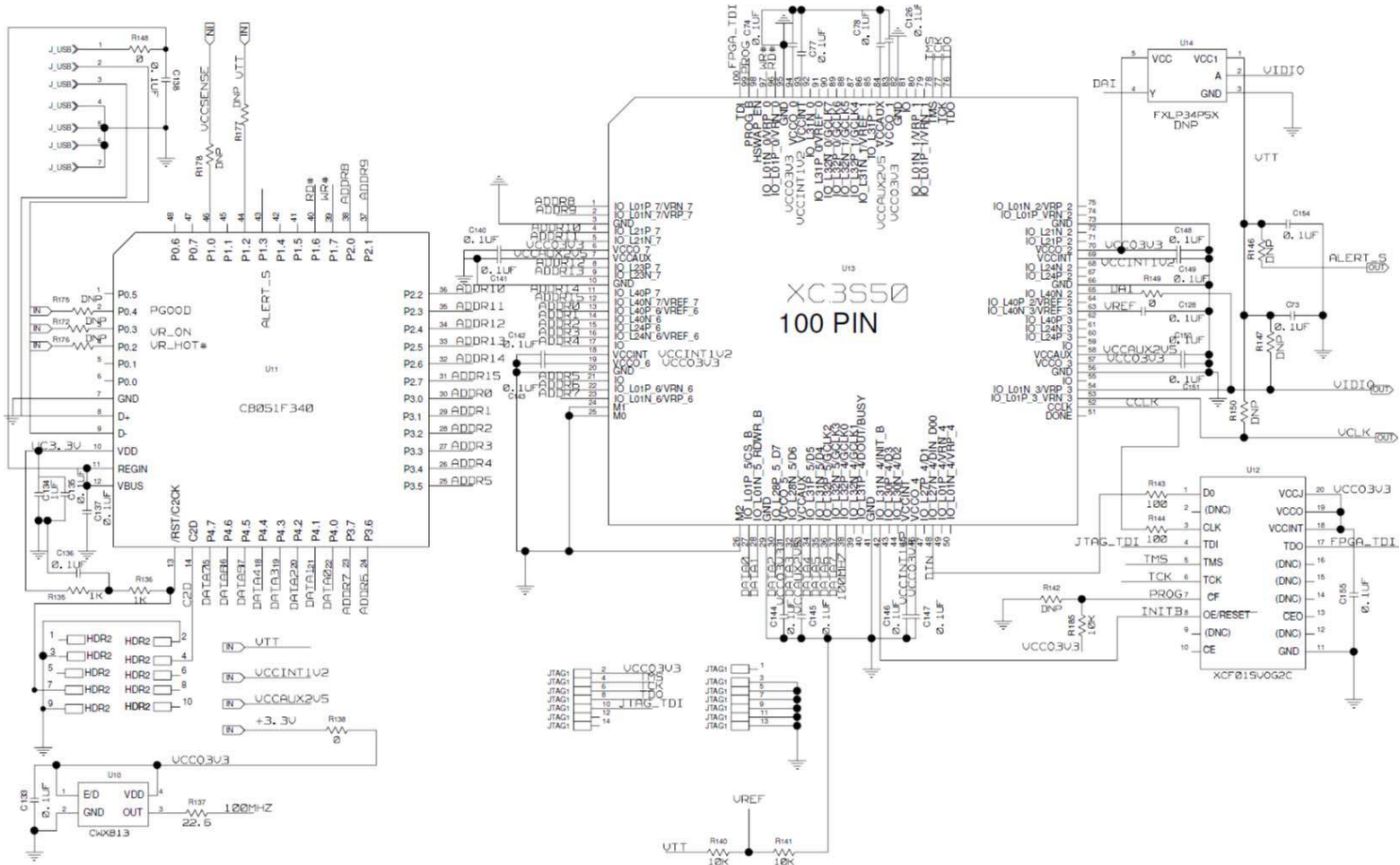

# Evaluation Board Schematic (Continued)

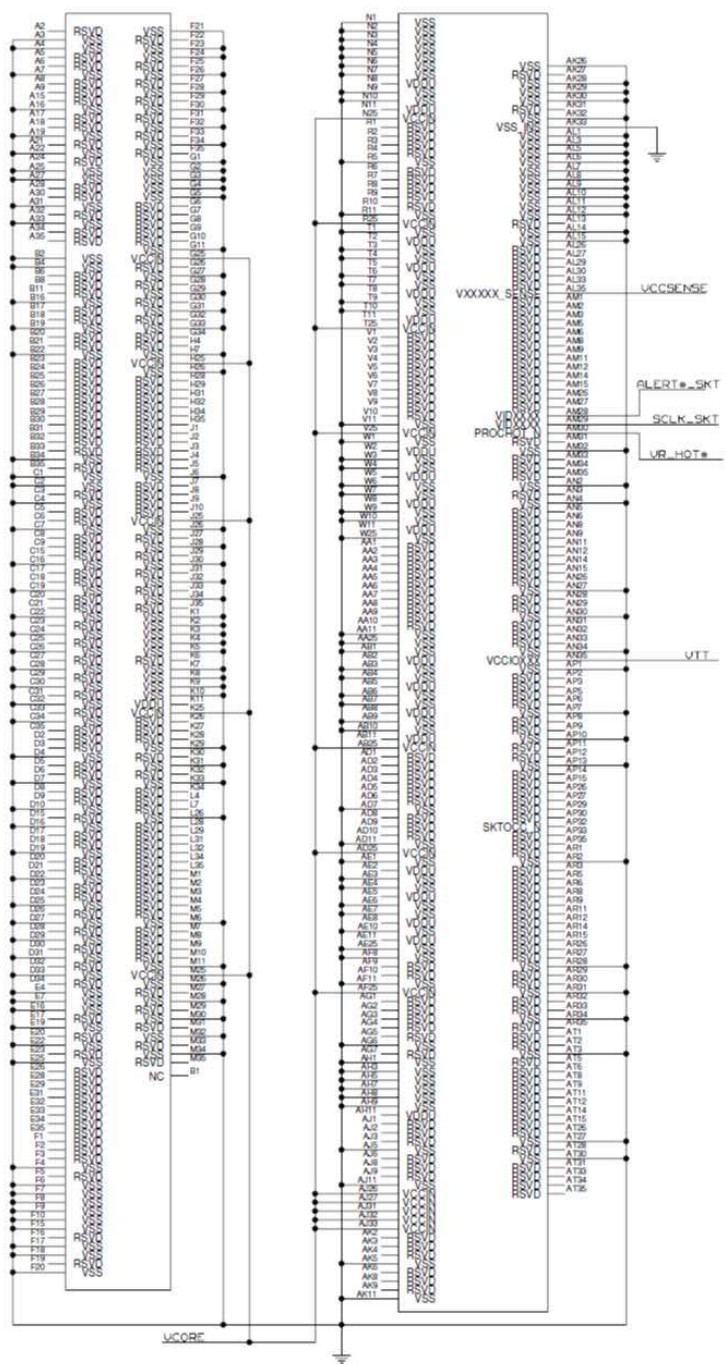
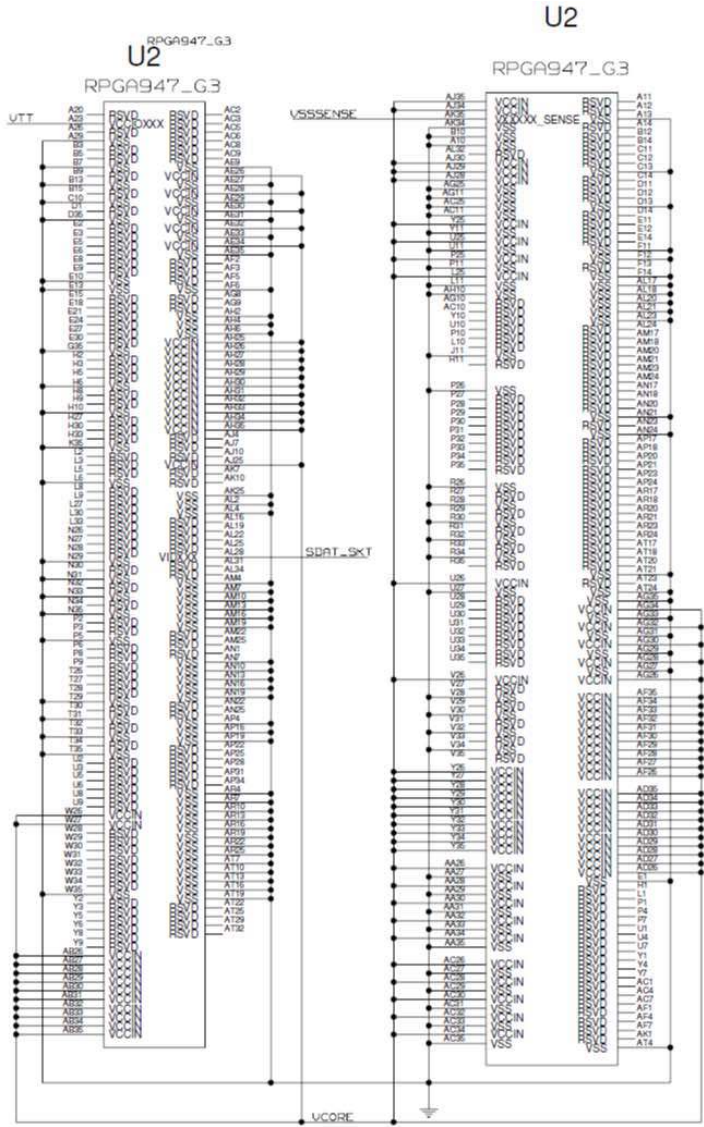

**Layer Plots** The following figures showcase the layout of the ISL95813 Evaluation Board. Layers 2 and 5 are excluded as they're both simply ground planes.

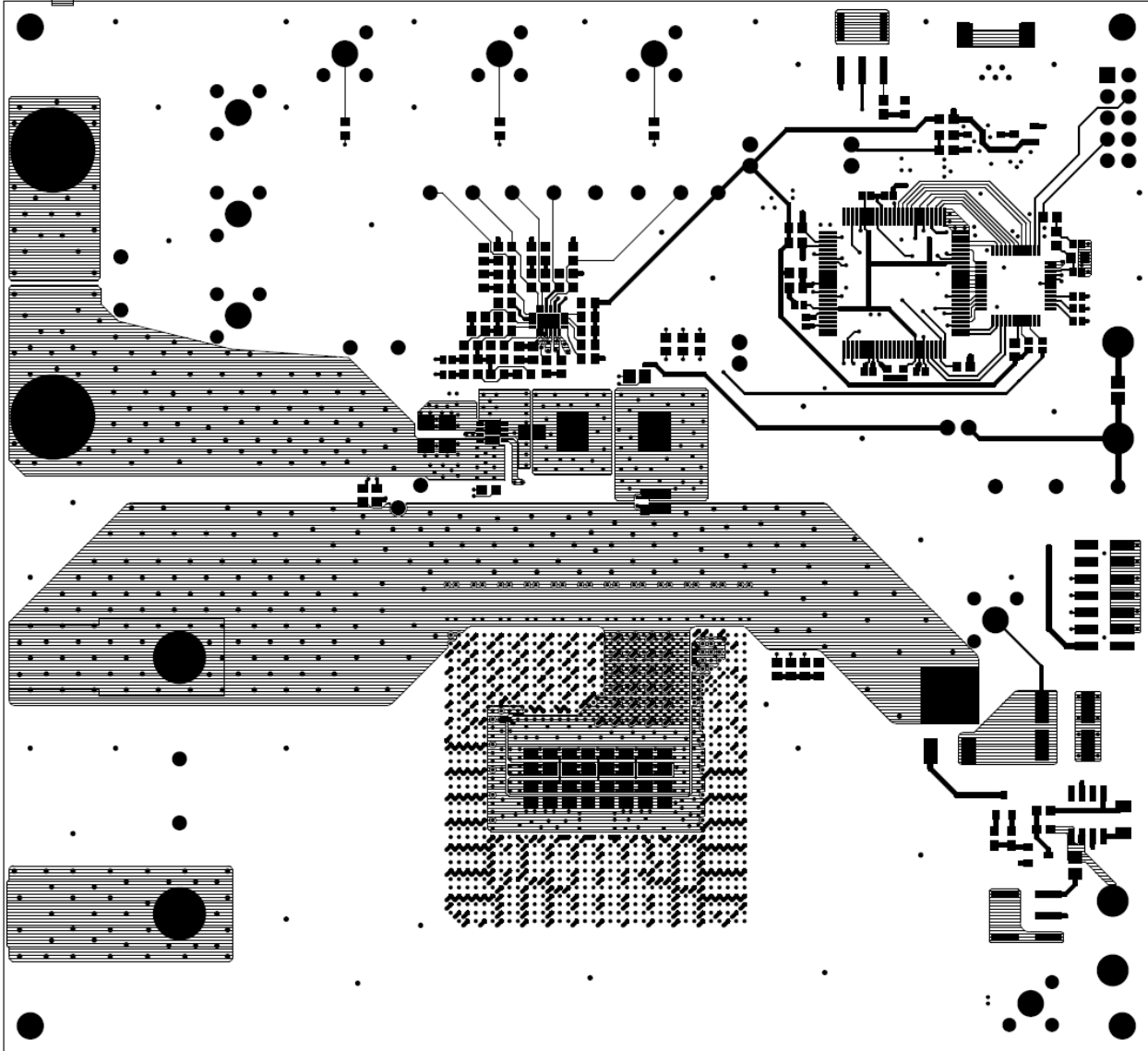

FIGURE 2. EVAL BOARD LAYER 1 (TOP)



**Layer Plots** The following figures showcase the layout of the ISL95813 Evaluation Board. Layers 2 and 5 are excluded as they're both simply ground planes. (Continued)

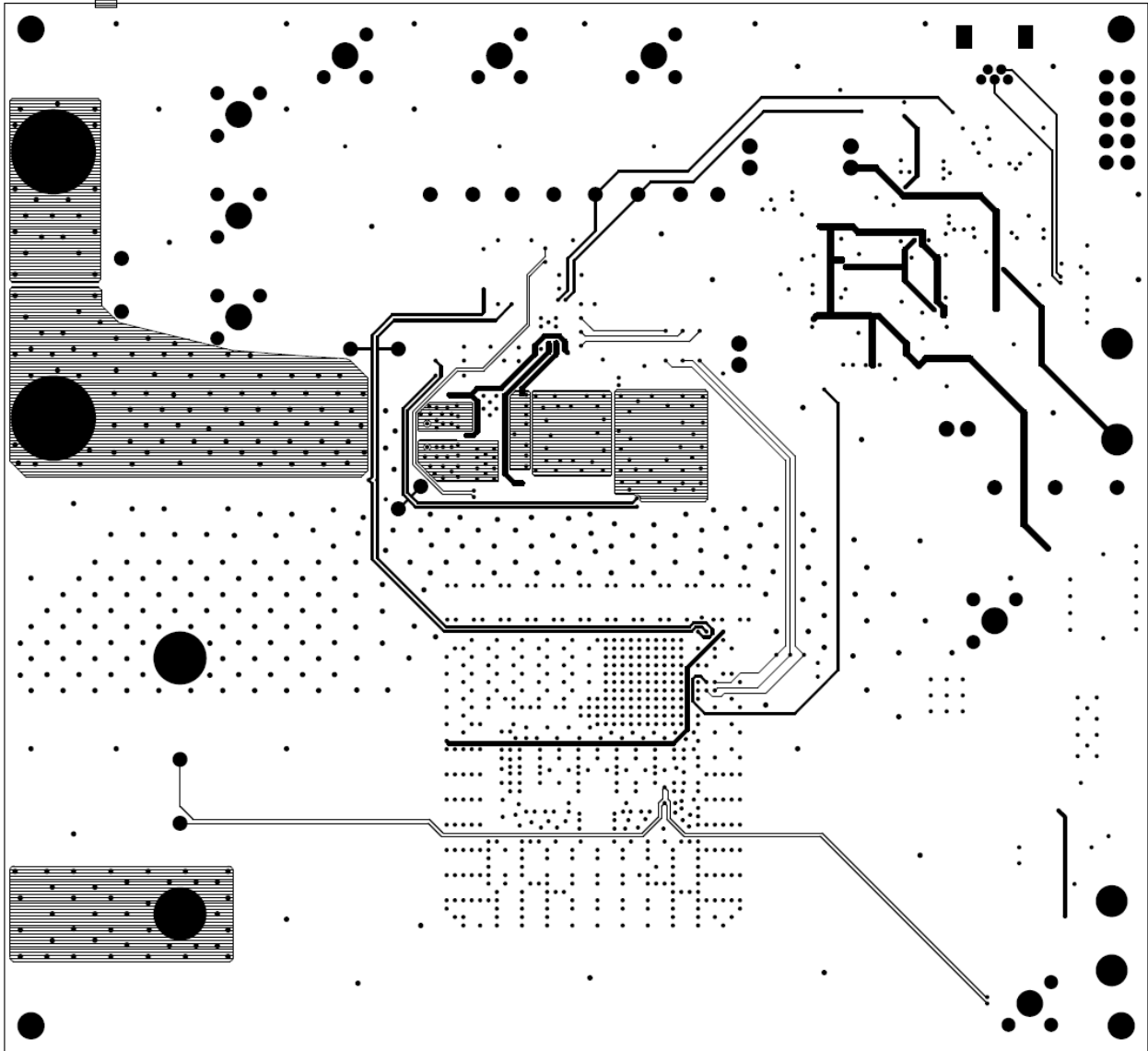

FIGURE 3. EVAL BOARD LAYER 3 (INTERNAL)

**Layer Plots** The following figures showcase the layout of the ISL95813 Evaluation Board. Layers 2 and 5 are excluded as they're both simply ground planes. (Continued)

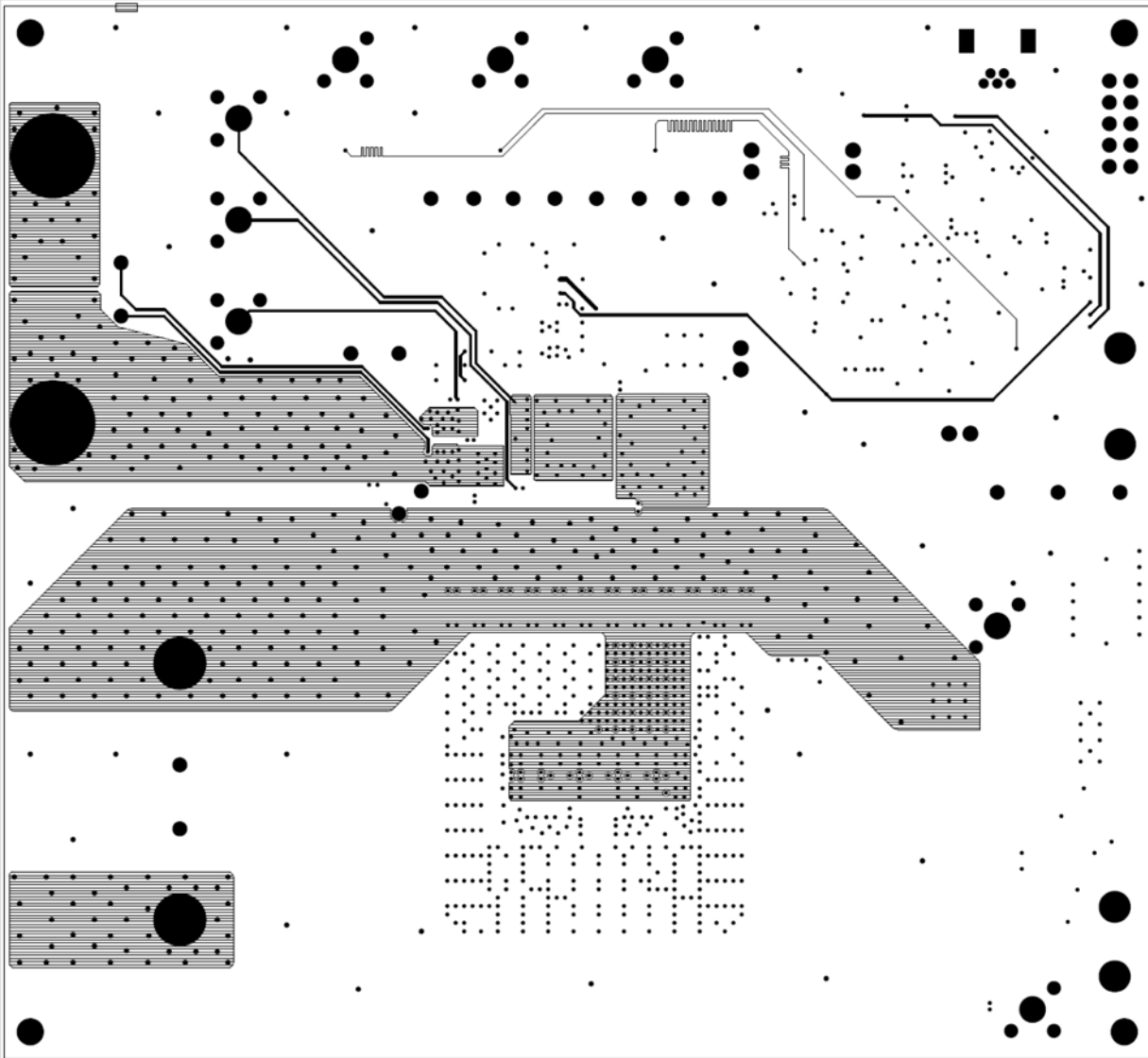

FIGURE 4. EVAL BOARD LAYER 4 (INTERNAL)

**Layer Plots** The following figures showcase the layout of the ISL95813 Evaluation Board. Layers 2 and 5 are excluded as they're both simply ground planes. (Continued)

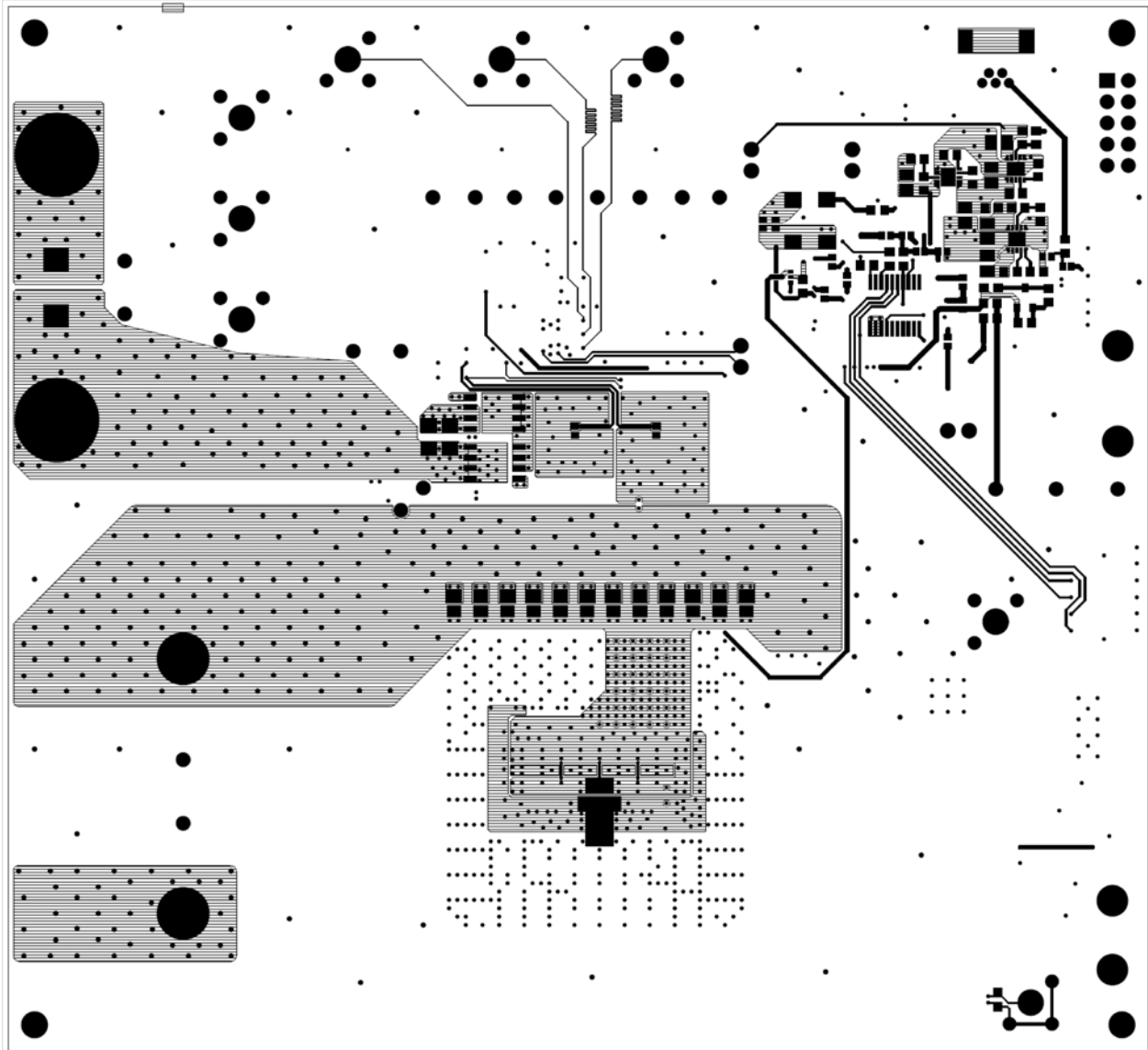
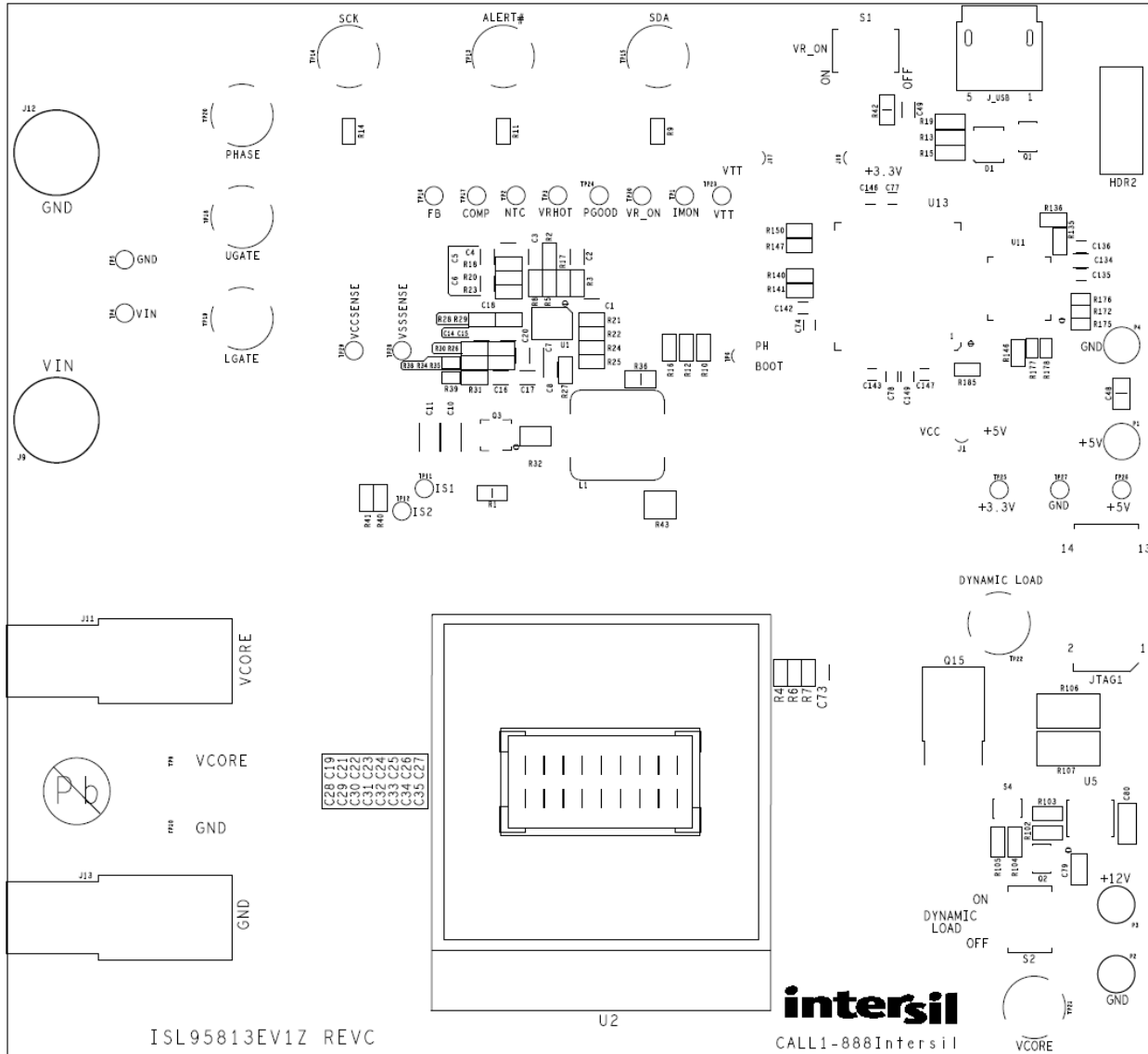

FIGURE 5. EVAL BOARD LAYER 6 (BOTTOM)

# Application Note 1846

**Layer Plots** The following figures showcase the layout of the ISL95813 Evaluation Board. Layers 2 and 5 are excluded as they're both simply ground planes. (Continued)



**FIGURE 6. TOP LAYER SILKSCREEN**

# Application Note 1846

**Layer Plots** The following figures showcase the layout of the ISL95813 Evaluation Board. Layers 2 and 5 are excluded as they're both simply ground planes. (Continued)

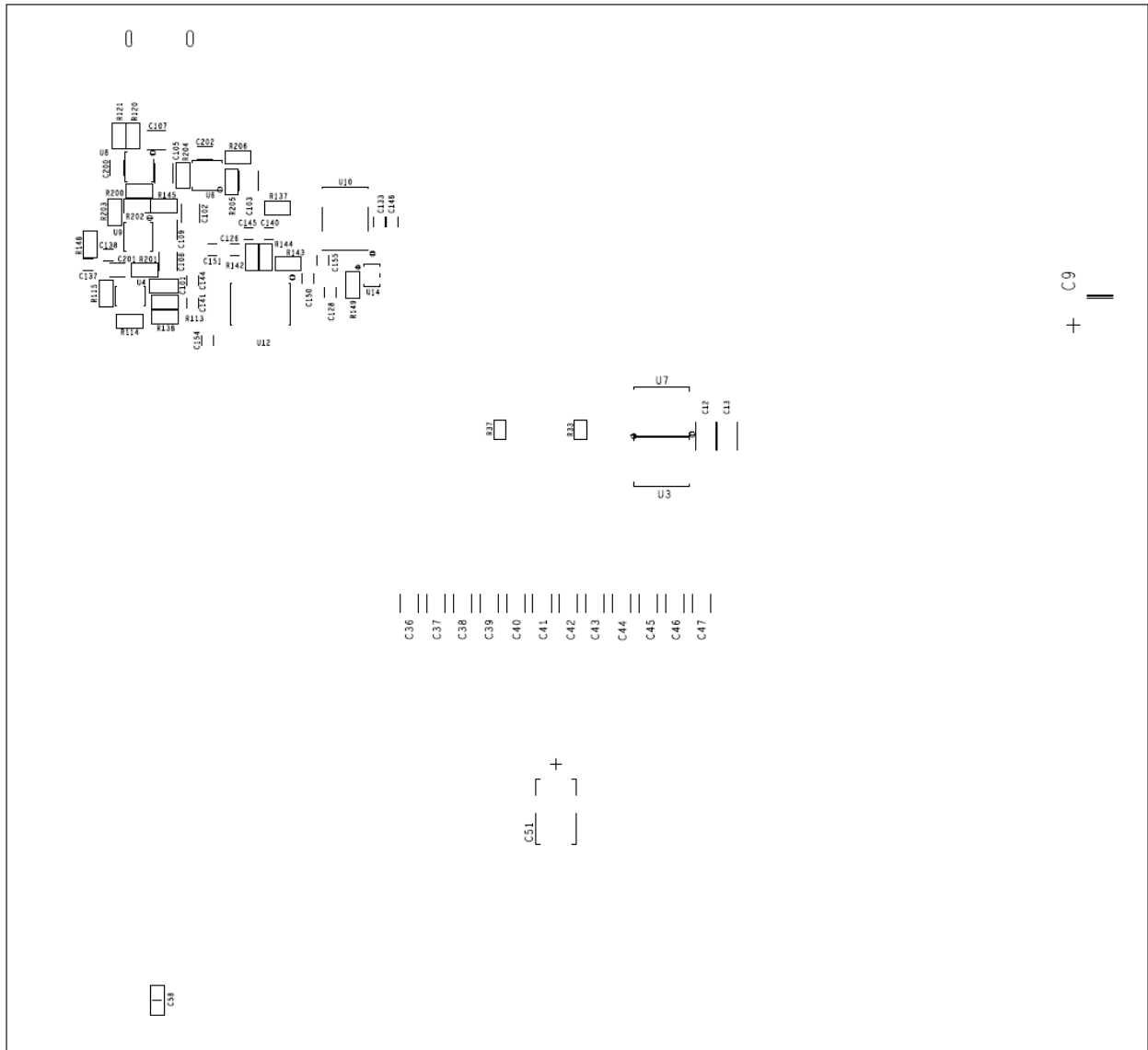

FIGURE 7. BOTTOM LAYER SILKSCREEN

## Application Note 1846

### Evaluation Board Bill of Materials Items highlighted in red are not populated.

DESIGNATOR	DESCRIPTION	PN	MFR	QTY	BOTTOM
C1, C7, C18, C73	0.1μF, 0603, 16V Ceramic	any	any	4	
C74, C77, C78, C133, C135, C136, C142, C143, C146-C148	0.1μF, 0402, 16V Ceramic	any	any	25	C126, C128, C137, C138, C140, C141, C144, C145, C149, C150, C151, C154, C155
C6	82pF, 0603, 16V, Ceramic	any	any	1	
	1000pF, 0603, 16V, Ceramic	any	any	3	C200-C202
C2	2200pF, 0603, 16V, Ceramic	any	any	1	
C3	6800pF, 0603, 16v, Ceramic	any	any	1	
C49	0.01μF, 0603, 16V Ceramic	any	any	2	C101
C15	0.056μF, 0603, 16V Ceramic	any	any	2	C58
C20, C134	1μF, 0603, 16V, Ceramic	any	any	2	
C48, C79	1μF, 0805, 16V, Ceramic	any	any	8	C102, C103, C105, C107, C108, C109
C8	0.22μF, 0603, 16V Ceramic	any	any	1	
C80	10μF, 1206, 16V Ceramic	any	any	1	
C10, C11	22μF, 1206, 25V, Ceramic	any	any	4	C12, C13
C19, C21-C27, C30-C33	22μF, 0805, 6.3V, Ceramic	any	any	14	C39, C40
	100μF, 25V, Tant	T491X107K025ZT	Kemet	1	C9
D1	LED, SMD, 3x2.5mm, 4P, RED/GREEN, 12/20MCD, 2V	SSL-LXA3025IGC-TR	Lumex	1	
S4	DIODE-SWITCHING, SMD, SOT23, 70V, 0.2A, ROHS	BAV99LT1G-T	ON Semi	1	
L1	0.15μH, 0.9mΩ, 7x7mm	MPCH0740LR15	Tokin	1	
Q1, Q2	N-Channel MOSFET, SOT23-3, 2N7002	2N7002-TP	Micro Commercial Co	2	
Q15	N-Channel MOSFET, TO-252	SUD50N03-07	Vishay	1	
R9, R10, R11, R12, R16, R20, R27	0Ω, 0603	any	any	13	R33, R37, R138, R145, R148, R149
R32	0Ω, 0805	any	any	1	
R107	RES 0.50Ω 1W 1% 2512 SMD	WSL2512R5000FEA	Vishay	1	
R106	RES 0.07Ω 1W 1% 2512 SMD	WSL2512R0700FEA	Vishay	1	
R40, R41	10Ω, 0603, 1%	any	any	2	
R104, R105	11Ω, 0603, 1%	any	any	2	
	22.6Ω, 0603, 1%	any	any	1	R137
	49.9Ω, 0603, 1%	any	any	1	R113
R4, R21	54.9Ω, 0603, 1%	any	any	2	
R6, R22	75Ω, 0603, 1%	any	any	2	
	100Ω, 0603, 1%	any	any	2	R143, R144
R7, R24	130Ω, 0603, 1%	any	any	2	

## Application Note 1846

### Evaluation Board Bill of Materials Items highlighted in red are not populated. (Continued)

DESIGNATOR	DESCRIPTION	PN	MFR	QTY	BOTTOM
R13, R15, R17, R103	499Ω, 0603, 1%	any	any	4	
R29	549Ω, 0603, 1%	any	any	1	
R135, R136	1kΩ, 0603, 1%	any	any	5	R121, R203, R206
	1.1kΩ, 0603, 1%	any	any	1	R120
R23	1.82kΩ, 0603, 1%	any	any	2	R205
R35	2.61kΩ, 0603, 1%	any	any	1	
R5	3.83kΩ, 0603, 1%	any	any	1	
R34	3.65kΩ, 0603, 1%	ERJ-3EKF3651V	Panasonic	1	
	5.62kΩ, 0603, 1%	any	any	1	R202
R8	5.90kΩ, 0603, 1%	any	any	1	
R19, R42, R140, R141, R185	10kΩ, 0603, 1%	any	any	10	R114, R115, R200, R201, R204
R30	11kΩ, 0603, 1%	any	any	1	
R2	24.3kΩ, 0603, 1%	any	any	1	
R102	49.9kΩ, 0603, 1%	any	any	1	
R3	113kΩ, 0603, 1%	any	any	1	
R26	154kΩ, 0603, 1%	any	any	1	
R25	205kΩ, 0603, 1%	any	any	1	
R36	THERMISTOR, SMD, 0603, 10K, 1/10W, 5%	ERT-J1VR103J	Panasonic	1	
R1	THERMISTOR-NTC, SMD, 0603, 470K, 1/10W, 5%	NCP18WM474J03RB	MURATA	1	
R43	Precision 4 Terminal Current Sense Resistor	RL1632L4		1	
S1, S2	SWITCH-TOGGLE, SMD, 6PIN, SPDT, 2POS, ON-ON, ROHS	GT11MSCBE	C&K	2	
J9	Banana Jack - Red	111-0702-001	Emerson	1	
J11, J13	HDWARE, MTG, CABLE TERMINAL, 6-14AWG, LUG&SCREW, ROHS	KPA8CTP	Berg	2	
J12	Banana Jack - Black	111-0703-001	Emerson	1	
J_USB	CONN-USB MINI-B RECEPTACLE, TH, 5CIRCUIT, R/A, ROHS	54819-0519	Molex	1	
HDR2	CONN-HEADER, TH, 2X5, 2.54mm, TIN, VERTICAL, ROHS	901310125	Molex	1	
JTAG1	CONN-HEADER, SHROUDED, SMD, 14P, 2mmPITCH, CENTER SLOT, ROHS	87832-1420	Molex	1	
P1-P4	Turret Binding Posts	1514-2	Keystone	4	
TP1-TP5, TP9-TP12, TP16, TP17, TP23-TP30	Conn-Gen, Compact Test Point, Vertical, White	5007	Keystone	20	
TP6, J1, J17, J19	Berg, 3 Pin Jumper, 100 mil spacing	any	any	4	
TP13-TP15, TP18-TP22	CONN-SCOPE PROBE TEST PT, COMPACT, PCB MNT, ROHS	131-4353-00	Tektronix	8	
U1	Single Phase Buck Regulator Controller	ISL95813	Intersil	1	
U2	CONN-DEV.SOCKET, SMD, 47x39.5, 947P, RPGA, ROHS	PZ94726-3641-41H	Foxconn	1	
	MOSFET N-CH 30V 17A TDSO-N	BSC052N03LS	Infineon	1	U3
	MOSFET N-CH 30V 100A 8TDSO-N	BSC011N03LS	Infineon	1	U7

## Application Note 1846

### Evaluation Board Bill of Materials Items highlighted in red are not populated. (Continued)

DESIGNATOR	DESCRIPTION	PN	MFR	QTY	BOTTOM
	IC-PREC.VOLTAGE REF., SMD, SOT-23, 1.24-10V, 12mA, ROHS	LM4041DIM3-ADJ/NOPB-T	National Semi	1	U4
	IC-ADJ.V, 1A LDO REGULATOR, 10P, DFN, 3X3, ROHS	ISL80101IRAJZ	Intersil	3	U6, U8, U9
U5	HIP2100 High Freq Half Bridge Driver	HIP2100	Intersil	1	
	OSC-CLOCK , CRYSTAL, SMD, 5X7, 3.3V, 100MHz, 25ppm, ROHS	CWX813-100.0M	Connor-Winfield	1	U10
U11	IC-FLASH, 64K, MICROCONTROLLER, 48P, TQFP, 48MHZ, ROHS	C8051F340-GQ	Silicon Laboratories	1	
	IC-PLATFORM FLASH PROM, 1Mb, 20P, TSSOP, ROHS	XCF01SVOG20C	Xilinx	1	U12
U13	IC-STD.FPGA SPARTAN-3, SMD, 100P, VTQFP, ROHS	XC3S50-4VQG100C	Xilinx	1	
R107	0.1Ω, 2512, 1%	any	any	1	
R18, R28, R31 R38, R39, R146, R147, R150	Res, 0603	any	any	8	R142
R172, R175, R176, R177, R178	Res, 0402	any	any	5	
C4, C5, C14, C16, C17	Ceramic, 0603	any	any	7	
Q3	Power Stage, 25V, QFN	FDPC8011S	Fairchild	1	
	22μF, 0805, 6.3V, Ceramic	any	any	12	C36-C47
C51	220μF, 2.5V POSCAP	any	Sanyo	1	C51
U14		FLXP34P5X		1	U14

Intersil Corporation reserves the right to make changes in circuit design, software and/or specifications at any time without notice. Accordingly, the reader is cautioned to verify that the Application Note or Technical Brief is current before proceeding.

For information regarding Intersil Corporation and its products, see [www.intersil.com](http://www.intersil.com)