

PAGE 1/2

ISSUE 25-11-22

SERIE : SPnT

PART NUMBER : R574F83285

RF CHARACTERISTICS

Number of ways : 12
Frequency range : 0 - 18 GHz
Impedance : 50 Ohms

Frequency (GHz)	DC - 3	3 - 8	8 - 12.4	12.4 - 15	15 - 18
VSWR max	1,20	1,40	1,60	1,70	1,80
Insertion loss max	0.20 dB	0.40 dB	0.60 dB	0.70 dB	0.80 dB
Isolation min	80 dB	70 dB	60 dB	60 dB	50 dB
Average power (*)	240 W	150 W	120 W	110 W	100 W

TERMINATION IMPEDANCE : 50 Ohms
TERM. AVG. POWER AT 25° C : 1 W per termination / 3 W total power

ELECTRICAL CHARACTERISTICS

Actuator : LATCHING
Nominal current ** : 500 mA
Actuator voltage (Vcc) : 28V (24 to 30V)
Terminals : 44 pins D-SUB male connector
Self cut-off time : 40 ms < CT < 120 ms
BCD inputs (E) - High level : 3.5 to 5.5 V / 800µA at 5.5 V
- Low level : 0 to 1.5 V / 20µA at 0.8 V

MECHANICAL CHARACTERISTICS

Connectors : SMA female per MIL-C 39012
Life : 2 million cycles per position
Switching Time*** : < 50 ms
Construction : Splashproof
Weight : < 400 g

ENVIRONMENTAL CHARACTERISTICS

Operating temperature range : -40°C to +85°C
Storage temperature range : -55°C to +85°C

(* Average power at 25°C per RF Path)

(** At 25° C ±10%)

(*** Nominal voltage ; 25° C)



PAGE 2/2

ISSUE 25-11-22

SERIE : SPnT

PART NUMBER : R574F83285

DRAWING

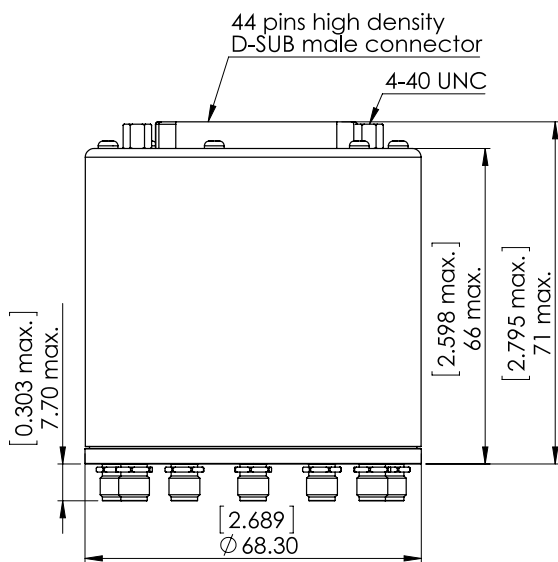
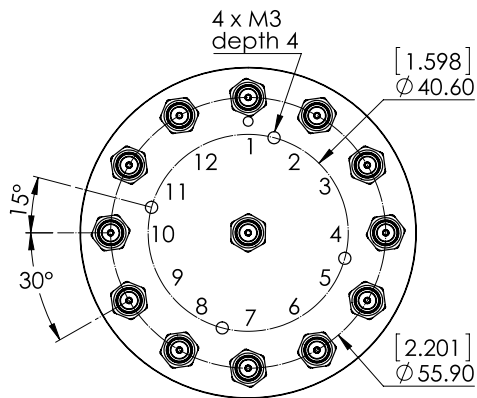

General tolerances : ±0,5 mm [0,02 in]

BCD TRUTH TABLE				
E4	E3	E2	E1	RF continuity
0	0	0	0	All ports open (Forced Reset)
0	0	0	1	IN ↔ 1
0	0	1	0	IN ↔ 2
0	0	1	1	IN ↔ 3
0	1	0	0	IN ↔ 4
0	1	0	1	IN ↔ 5
0	1	1	0	IN ↔ 6
0	1	1	1	IN ↔ 7
1	0	0	0	IN ↔ 8
1	0	0	1	IN ↔ 9
1	0	1	0	IN ↔ 10
1	0	1	1	IN ↔ 11
1	1	0	0	IN ↔ 12

LABEL

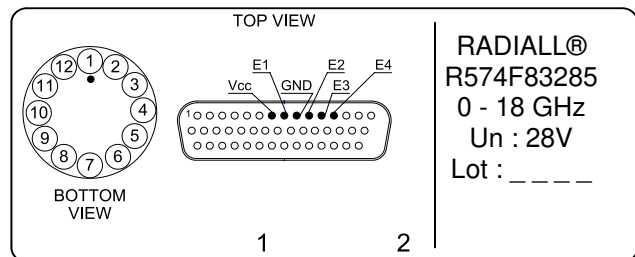

SCHEMATIC DIAGRAM

