

AS1320

Demoboard Application Note

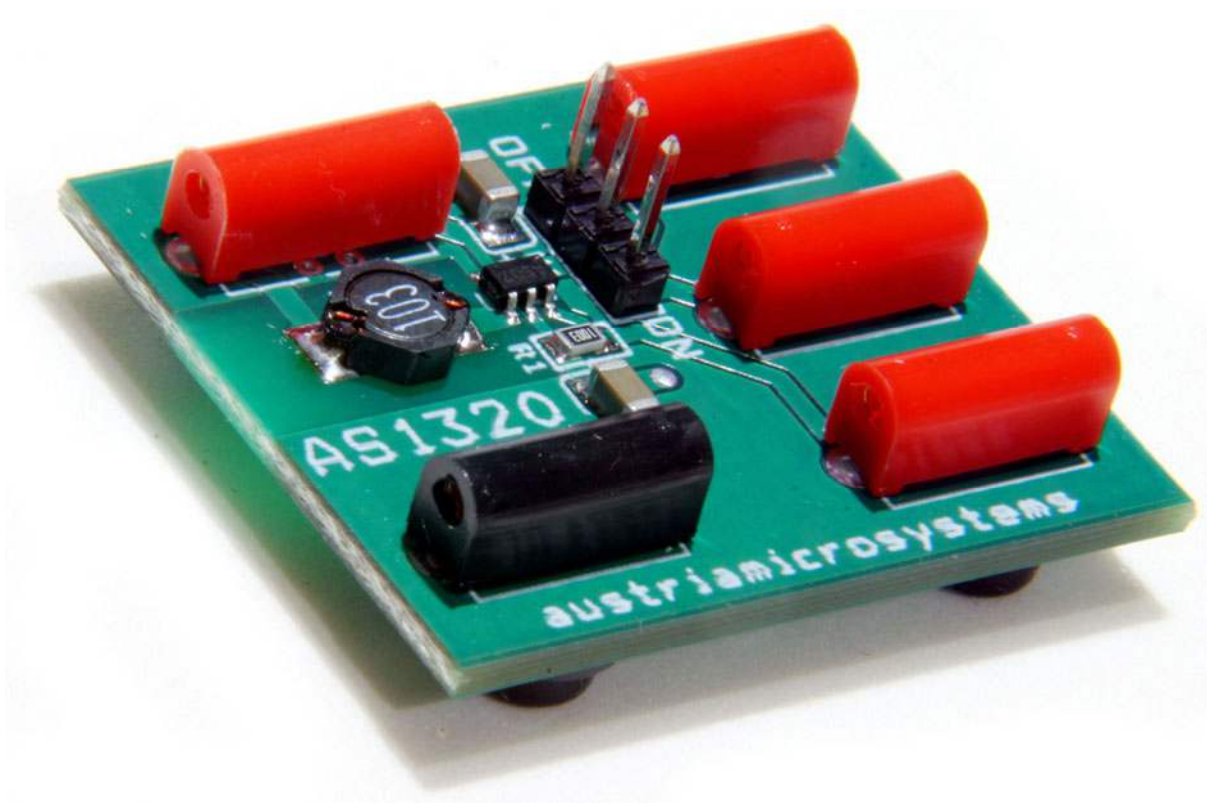

General Description

Jumper Description

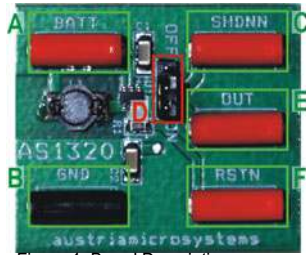

Figure 1: Board Description

Label	Jumper	Description	Info
A	BATT	Power Supply Connectors for VBATT and Ground.	+1.5V to +3.5V
B	GND		
C	SHDNN	Active-Low Logic Shutdown Input	1/ON = The AS1320 is on.
D	OFF/ON	SHDNN Shutdown Jumper	0/OFF = The AS1320 is off and the current into BATT is $\leq 1 \mu\text{A}$ (typ).
E	OUT	Power Output Connector	Fixed power output of 3.3V
F	RSTN	Active-Low Reset Output Connector	

Operational sequence

1. If not present get the datasheet for the AS1320 from www.austriamicrosystems.com. Drive the IC on the Demoboard only with the recommended settings and values as described in the datasheet.
2. Connect a +1.5V to +3.5V power supply (BATT "A" and GND "B").
3. Perform measurements at the output OUT "E"

Have fun using the Demoboard. If there are questions do not hesitate to contact us. See contact information at the end of the application note.

Layout of demoboard

Board schematics and layout

Figure 2: Schematics

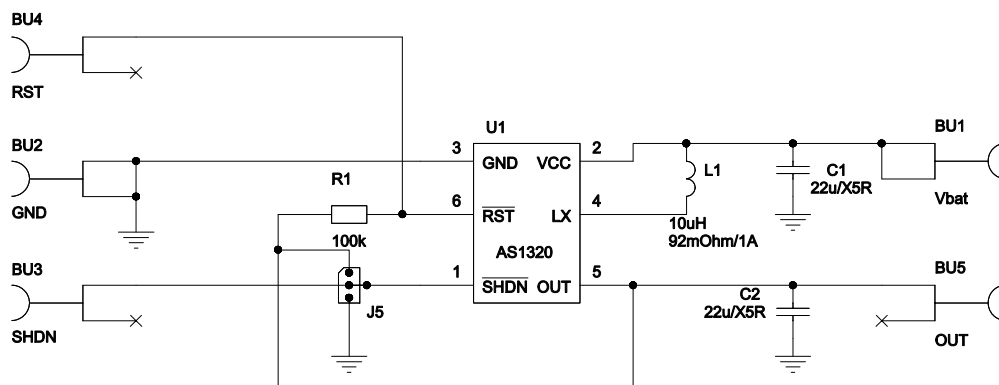

Figure 3: Top view

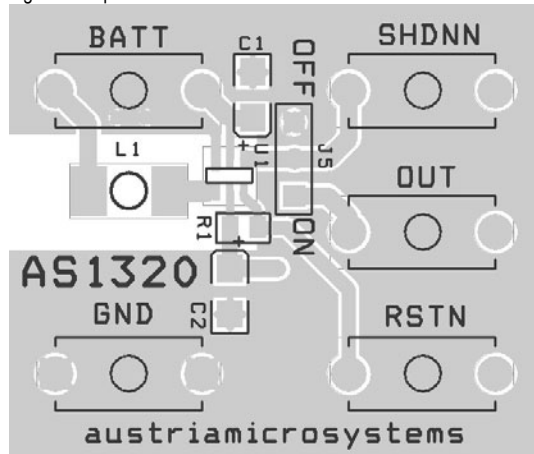
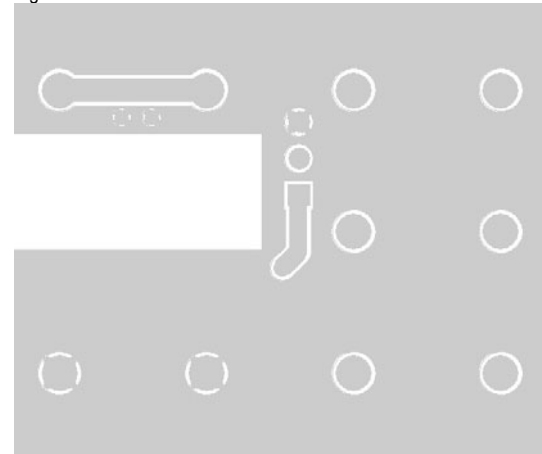
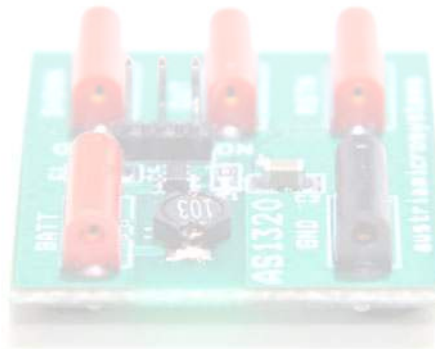

Figure 4: Bottom view



Assembly List

Label	Value	Type
C1	22uF	1206 X5R Ceramic
C2	22uF	1206 X5R Ceramic
L1	10uH	MOS6020-103



Copyright

Copyright © 2006 austriamicrosystems. Trademarks registered ©. All rights reserved. The material herein may not be reproduced, adapted, merged, translated, stored, or used without the prior written consent of the copyright owner. To the best of its knowledge, austriamicrosystems asserts that the information contained in this publication is accurate and correct.

Contact Information

Headquarters:

austriamicrosystems AG
 Standard Linear
 A 8141 Schloss Premstätten, Austria
 T. +43 (0) 3136 500 0
 F. +43 (0) 3136 5692

For Sales Offices, Distributors and Representatives, please visit: www.austriamicrosystems.com