

CBM-90-IRD-X33-850nm

Mosaic Array Series

Infrared Chip On Board LEDs



Table of Contents

Technology Overview	2
Ordering Information	3
Binning Structure	4
Optical and Electrical Characteristics	5
Mechanical Dimensions	8
Packaging Information	9
Revision History	11

Features

- Mosaic Array Infrared LED chipset with surface emitting area of 9 mm²
- Vertical chip LED technology for high power density and uniform emission
- High thermal conductivity copper coreboard package
- Can be operated at variable drive currents up to 18A

Applications

- Medical and Scientific Instrumentation
- Fiber-coupled illumination
- Inspection
- Machine Vision

Technology Overview

Luminus CBM-90-IRD-X33 LEDs benefit from innovations in device technology, chip packaging and thermal management. This suite of technologies give engineers and system designers the freedom to develop solutions both high in power and efficiency.

Luminus LED Technology

Luminus' Devices vertical chip LED technology enables large area LED chips with uniform brightness over the entire LED chip surface. The optical power and brightness produced by these large monolithic chips enable solutions which replace arc and halogen lamps where arrays of traditional high power LEDs cannot.

Packaging Technology

Thermal management is critical in high power LED applications. With a thermal resistance from junction to heat sink of 0.5° C/W, Luminus CBM-90 LEDs have the lowest thermal resistance of any LED on the market. This allows the LED to be driven at higher current densities while maintaining a low junction temperature, thereby resulting in brighter solutions and longer lifetimes.

Reliability

Luminus CBM-90-IRD-X33 LEDs have passed a rigorous suite of environmental and mechanical stress tests, including mechanical shock, vibration, temperature cycling and humidity. They are fully qualified for use in a wide range of high performance and high efficacy applications.

REACH & RoHS Compliance

The Luminus CBM-90-IRD-X33 LED is compliant to the Restriction of Hazardous Substances Directive or RoHS. The restricted materials including lead, mercury cadmium hexavalent chromium, polybrominated biphenyls (PBB) and polybrominated diphenyl ether (PBDE) are not used.

Static Electricity

The products are sensitive to static electricity, and care should be taken when handling them. Static electricity or surge voltage will damage the LEDs. It is recommended to wear an anti-electrostatic wristband or an anti-electrostatic gloves when handling the LEDs. All devices, equipment and machinery must be properly grounded. It is recommended that measures be taken against surge voltage to the equipment that mounts the LEDs.

Reference: APN-002815 Electrical Stress Damage to LEDs and How to Prevent It

Understanding Luminus CBM-90-IRD-X33 LED Test Specifications

Every Luminus LED is fully tested to ensure it meets the high quality standards customers have come to expect from Luminus products.

Testing Temperature

Luminus CBM-90-IRD-X33 LEDs are tested and binned at 40°C heatsink temperature. Temperature curves are provided to allow users to scale the data for actual operating temperature conditions.

Ordering Information

All CBM-90-IRD-X33 products are packaged and labeled with part numbers as outlined in below. When shipped, each tray will contain only a single flux wavelength and Vf bin. The part number designation is as follows:

Ordering Part Numbers

Typ. Centroid Wavelength	Minimum Flux Bin	Lens Angle	Ordering Part Number
850 nm	K	120 (Lambertian)	CBM-90-IRD-X33-K850

Part Number Nomenclature

CBM

—

90

—

IRD

—

X33

—

F###

Product Family	Chip Area	Color	Package Configuration	Bin Kit ^{1,2}
CBM: Copper-core PCB, Multi Chip Array, No Encapsulation	90: 9 mm ²	IRD = Dual junction Infrared	X33: 28 mm x 26.75 mm - Common Anode Package See Mechanical Drawing section	See below for flux and wavelength binning information

CBM-90-IRD Binning Structure

All CBM-90-IRD LEDs are tested for radiometric power / peak wavelength and placed into one of the following flux / wavelength bins.

Radiometric Power Bins¹

Bin Code	Binning at 13.5A, $T_{hs} = 40\text{ }^{\circ}\text{C}$	
	Minimum Power (W)	Maximum Power (W)
K	11	12.1
L	12.1	13.31
M	13.31	14.64
N	14.64	16.11
P	16.11	17.72

Note 1: Luminus maintains a +/-6% tolerance in flux measurements.

Wavelength Bins

Bin Code	Binning at 13.5A, $T_{hs} = 40\text{ }^{\circ}\text{C}$	
	Minimum Peak Wavelength (nm)	Maximum Peak Wavelength (nm)
840	840	845
845	845	850
850	850	855
855	855	860
860	860	865
865	865	870

Note 2: The 3 digit wavelength bin as marked on the product label may be followed by a letter which is for internal use only.

Typical Device Performance¹

Parameter	Symbol	Value	Unit
Forward Current	I_f	13.5	A
Output Power Typical	PO_{typ}	13	W
Minimum Forward Voltage ¹	V_{fmin}	3.0	V
Forward Voltage Typical	V_f	3.6	V
Maximum Forward Voltage ¹	V_{fmax}	4.0	V
Viewing Angle	$2 \varnothing_{1/2}$	120	deg
Peak Wavelength Typical	λ_p	855	nm
Centroid Wavelength Typical	λ_c	850	nm
FWHM Typical	$\Delta\lambda_{1/2}$	35	nm
Temperature Coefficient of Forward voltage	TC_{Vf}	-2	mV/°C
Temperature Coefficient of Radiometric Power	TC_{PO}	-0.3	%/°C
Temperature Coefficient of Wavelength	TC_{λ}	0.2	nm/°C
Thermal Resistance (Electrical) ²	$R_{th(i-b)}$	0.5	°C/W
Emitting Area		10.24	mm ²
Emitting Area Dimensions		3.2 x 3.2	mm x mm

Note 1: Parts are tested and binned at a current of 13.5A, 20ms single pulse and a constant heatsink temperature of $T_{hs} = 40^\circ\text{C}$.

Note 2: Measurements are in accordance with JEDEC 51-14. For more about thermal resistance calculation, please see <https://luminusdevices.zendesk.com/hc/en-us/articles/4416807960717-Thermal-Heatsink-Required-Rth-Calculator>

Absolute Maximum Ratings^{3,6}

Parameter	Symbol	Value	Unit
Absolute Minimum Current (CW or pulse) ^{4,5}		0.2	A
Absolute Maximum Current (CW) ^{4,5}		18.0	A
Reverse Voltage	V_R	5	V
Storage Temperature	T_{STG}	-40~100	°C
Maximum Junction Temperature ^{4,5}	T_{jmax}	115 °C	°C

Note 3: To prevent damage refer to operating conditions and derating curves for appropriate maximum operating conditions

Note 4: Luminus CBM-90-IRD-X33 LEDs are designed for operation up to an absolute maximum forward drive current as specified above. Product lifetime data is specified at typical forward drive currents. Sustained operation at absolute maximum currents will result in a reduction of device lifetime compared to typical forward drive currents. Actual device lifetimes will also depend on junction temperature.

Note 5: Maximum operating case temperature combined with maximum drive current defines the total maximum operating condition for the device. To prevent damage, please operate devices within specified conditions.

Note 6: Caution must be taken not to stare at the light emitted from these LEDs. Under special circumstances, the high intensity could damage the eye.

Optical and Electrical Characteristics

Relative Radiometric Power vs. Forward Current

$\phi_v/\phi_v(13.5A)$, Single Pulse 20ms, $T_{hs} = 40^\circ C$

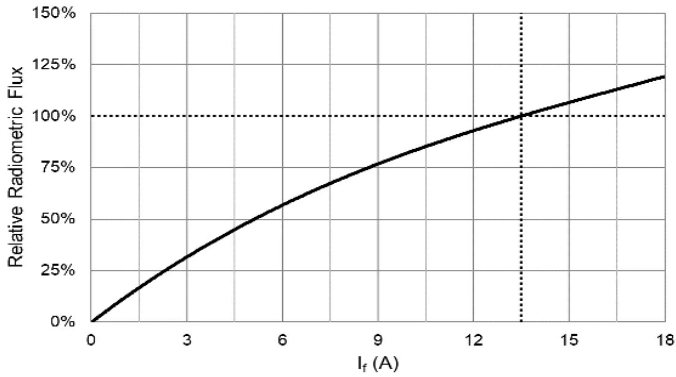

Relative Radiometric Power vs. Temperature

$\phi_v/\phi_v(40^\circ C)$, Single Pulse 20ms, $I_f = 13.5A$

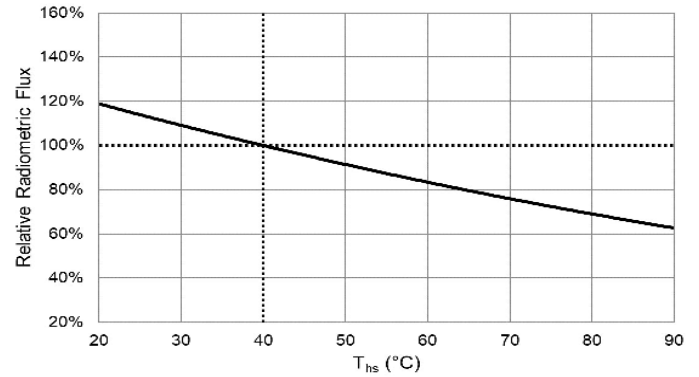

Forward Voltage vs. Forward Current

$V_f(I_f)$, Single Pulse 20ms, $T_{hs} = 40^\circ C$

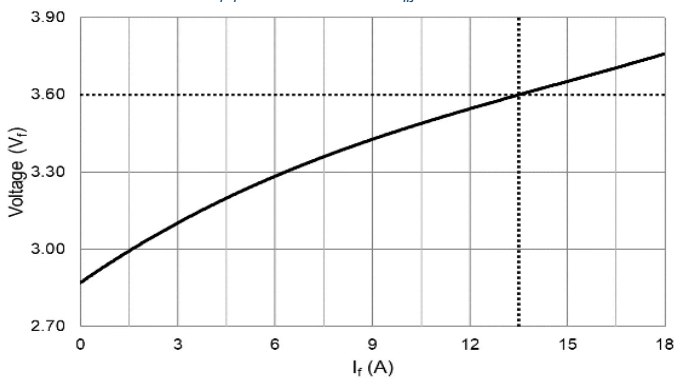

Forward Voltage Shift vs. Temperature

$\Delta V_f = V(T_{hs}) - V(40^\circ C)$, Single Pulse 20ms, $I_f = 13.5A$

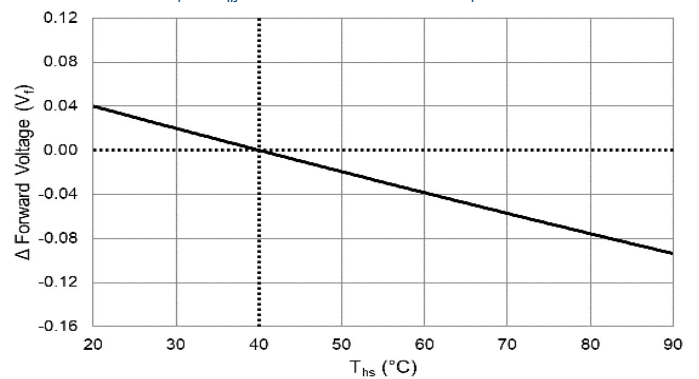

Typical Spectrum

$\Phi_{ref} = f(\lambda)$, Single Pulse 20ms, $I_f = 13.5A$, $T_{hs} = 25^\circ C$

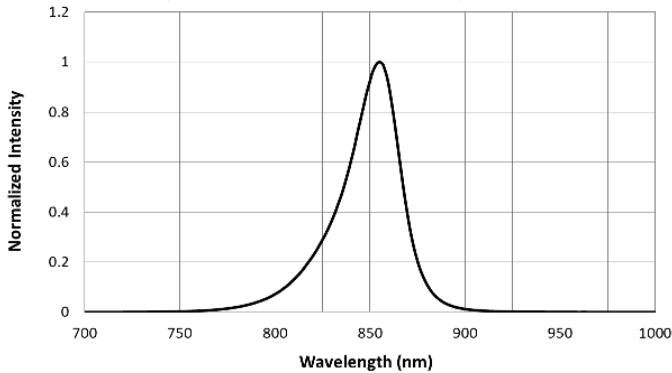

Peak Wavelength Shift vs. Temperature

$\Delta WL = WL(T_{hs}) - WL(40^\circ C)$, Single Pulse 20ms, $I_f = 13.5A$

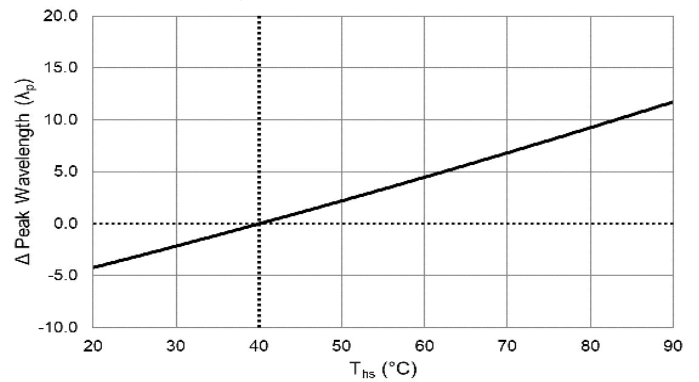

Mechanical Dimensions

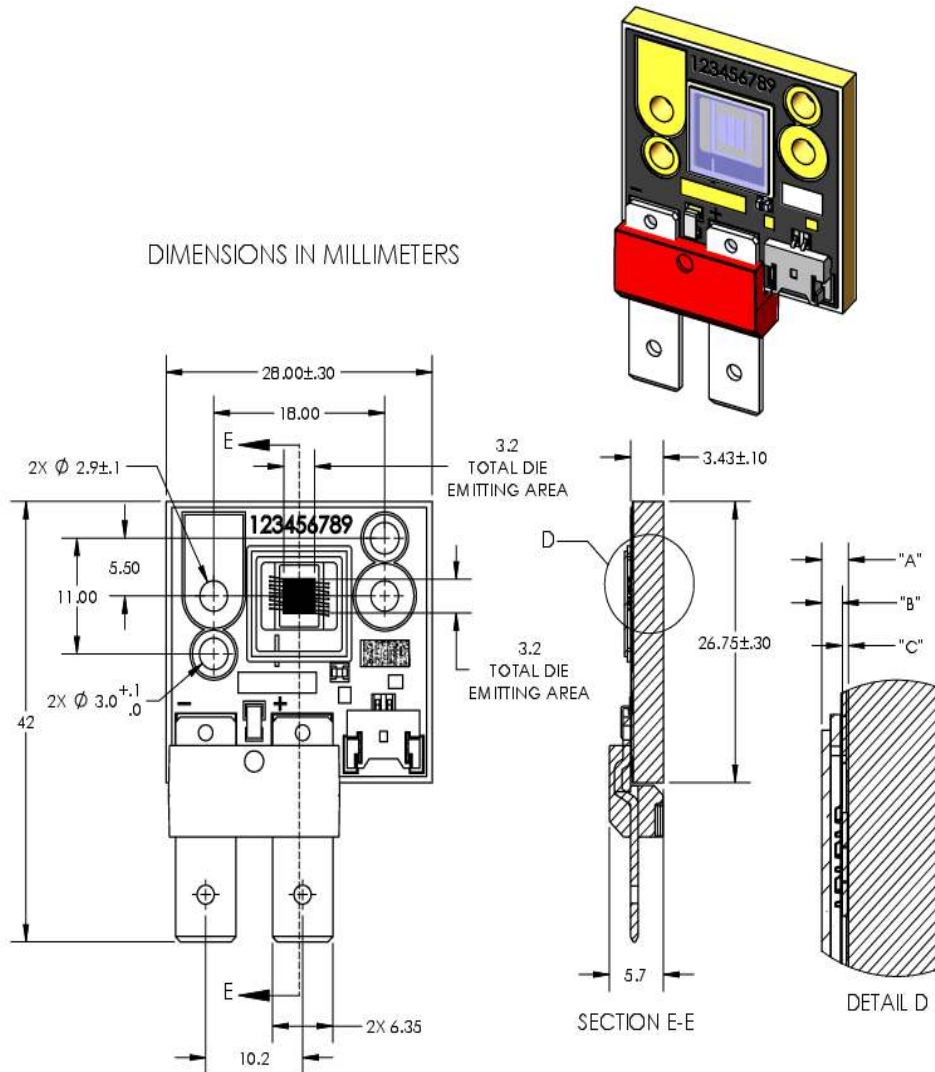

DIMENSION NAME	DESCRIPTION	NOMINAL DIMENSION	TOLERANCE
"A"	TOP OF METAL SUBSTRATE TO TOP OF WINDOW	.93	±.13
"B"	TOP OF DIE EMITTING AREA TO TOP OF WINDOW	.73	±.13
"C"	TOP OF METAL SUBSTRATE TO TOP OF DIE EMITTING AREA	.21	±.02

DWG-002978 REV01

Recommended connector for Anode and Cathode:

Panduit Disco Lok™ Series P/N: DNF14-250FIB-C or JST Manufacturing Co: SPS-61T-250 for AWG 16 to 14.

Panduit Disco Lok™ Series P/N: DNF10-250FIB-L or JST Manufacturing Co: SPS-91T-250 for AWG 12 to 10.

(Check NEC standards for ampacity of the power cable being used.)

Recommended Female for Thermistor Connector:

MOLEX P/N 51146-0200 (Not recommended for new designs), GCT P/N WTB06-020H-A or equivalent.

Shipping Tray Outline

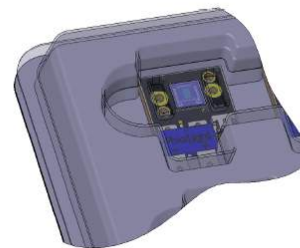
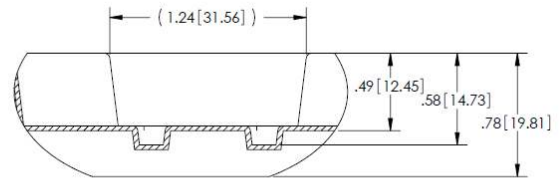
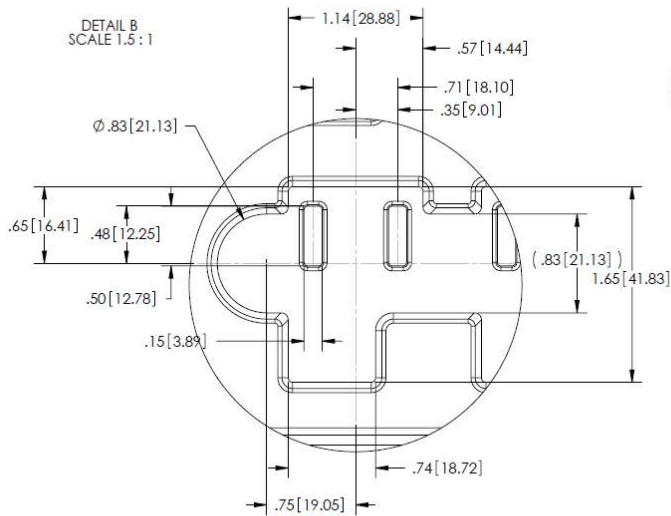
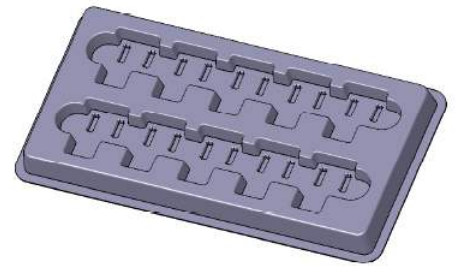
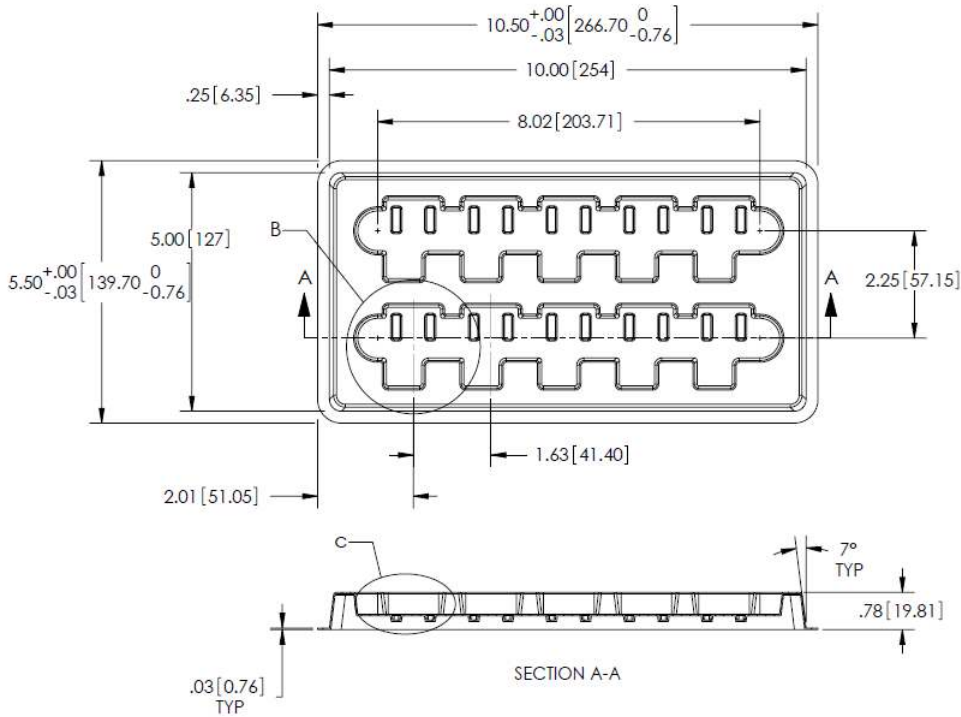

TOP TRAY SHOWN TRANSPARENT FOR REFERENCE ONLY

Shipping Label

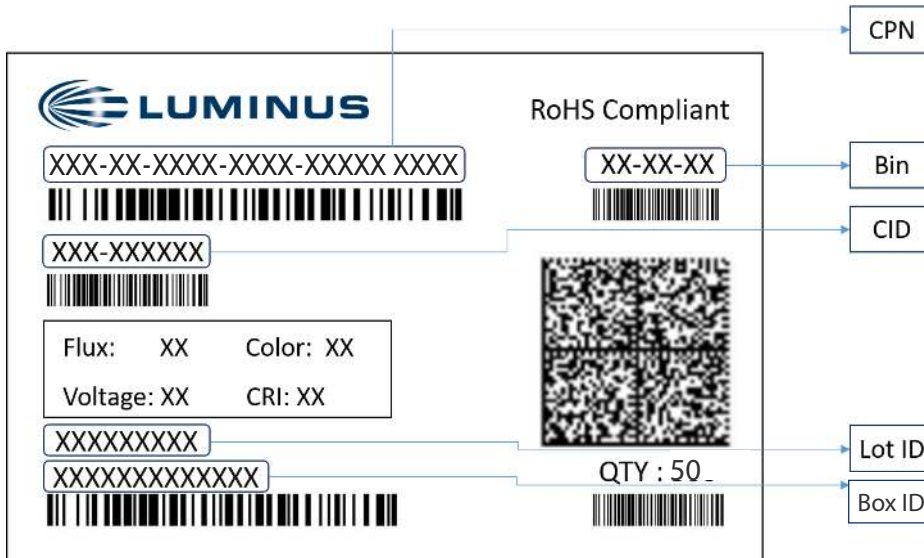

Label Fields:

- CPN: Luminus ordering part number
- CID: Customer's part number
- QTY: Quantity of devices in pack
- Flux: Bin as defined on page 4
- Voltage: NA
- Color: Bin as defined on page 4
- CRI: NA

Packing Configuration:

- Maximum: stack of 5 trays with 10 devices per tray per pack
- Partial pack or tray may be shipped
- Each pack is enclosed in antistatic bag
- Shipping label is placed on top of each pack

Revision History

Rev	Date	Description of Change
01	03/04/2020	Initial Release to Production Updated thermal coefficient of radiometric power and typical FWHM on page 5 Updated graphs on page 7 Updated mechanical drawing on page 8
02	08/04/2020	Updated product picture on front page Updated temperature coefficient of radiometric power and thermal resistance on page 5 Updated mechanical drawing on page 8
03	02/22/2022	Update technology overview Update ordering information Add Note 2. in binning structure Update typical spectrum Update shipping tray outline Update shipping label
04	07/11/2022	Update characteristic graphs and some editorial changes

The products, their specifications and other information appearing in this document are subject to change by Luminus Devices without notice. Luminus Devices assumes no liability for errors that may appear in this document, and no liability otherwise arising from the application or use of the product or information contained herein. None of the information provided herein should be considered to be a representation of the fitness or suitability of the product for any particular application or as any other form of warranty. Luminus Devices' product warranties are limited to only such warranties as accompany a purchase contract or purchase order for such products. Nothing herein is to be construed as constituting an additional warranty. No information contained in this publication may be considered as a waiver by Luminus Devices of any intellectual property rights that Luminus Devices may have in such information. Big Chip LEDs™ is a registered trademark of Luminus Devices, Inc., all rights reserved.

This product is protected by U.S. Patents 6,831,302; 7,074,631; 7,083,993; 7,084,434; 7,098,589; 7,105,861; 7,138,666; 7,166,870; 7,166,871; 7,170,100; 7,196,354; 7,211,831; 7,262,550; 7,274,043; 7,301,271; 7,341,880; 7,344,903; 7,345,416; 7,348,603; 7,388,233; 7,391,059 Patents Pending in the U.S. and other countries.