

This document is the property of Amphenol Corporation and is delivered on the express condition that it is not to be disclosed, reproduced or used, in whole or in part, for manufacture or sale by anyone other than Amphenol Corporation without its prior consent, & that no right is granted to disclose or to use any information in this document.

CUSTOMER DRAWING

REVISIONS

SYM	ECN	DESCRIPTION	DATE	APPROVED
1	CDXXXX	PROPOSAL	Jan.3,2020	YH
2	CDXXXX	ADD PACKING	Feb.18,2020	YH
3	CDXXXX	ADD AIC MATING CARD	May.18,2020	YH
3	CD2228	OFFICIAL RELEASE	May.18,2020	YH

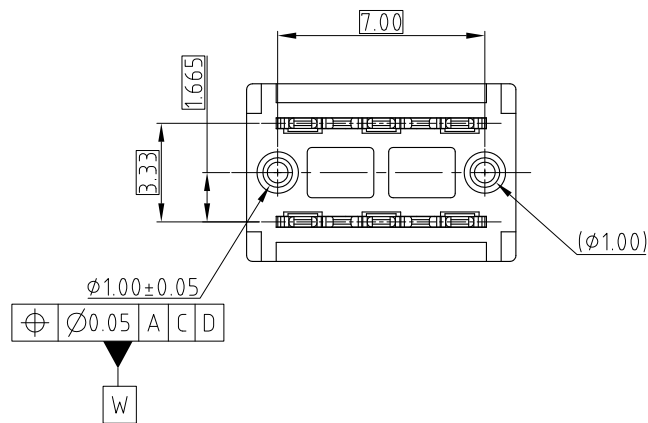
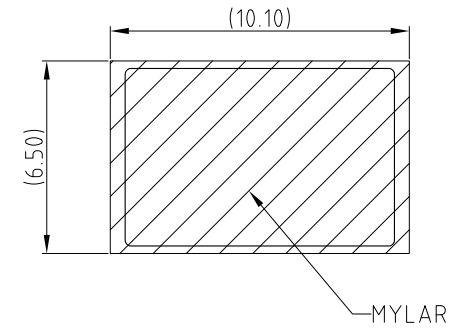
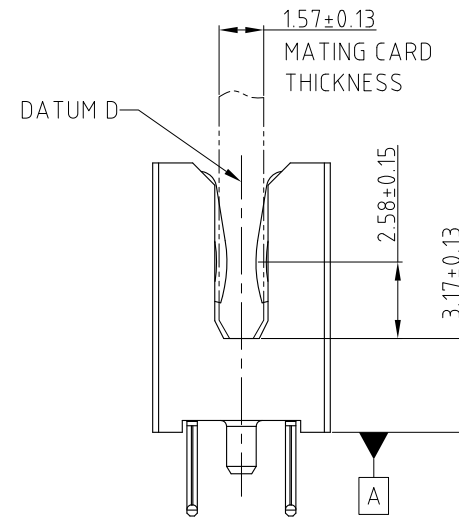
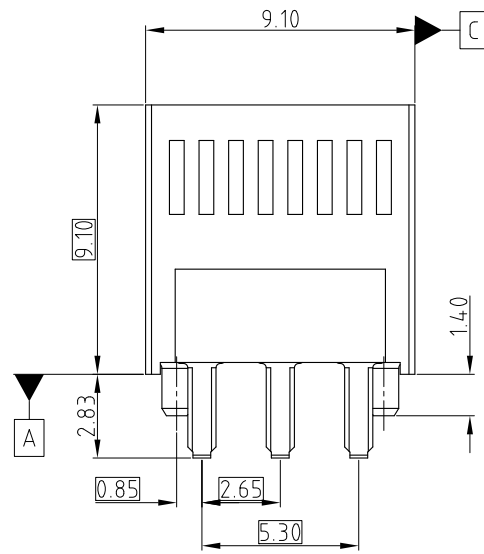
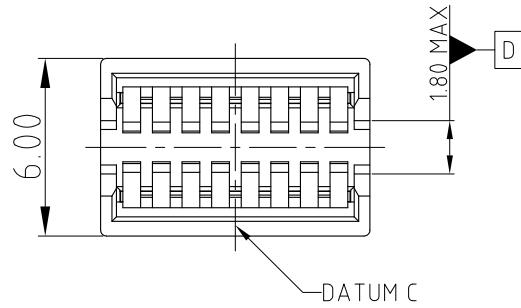

NOTE:

- MATERIAL:
HOUSING: HIGH TEMPERATURE THERMOPLASTIC, BLACK, UL94-V0
CONTACT: COPPER ALLOY
- FINISHED:
CONTACT: MATING AREA: 0.76 μ m MIN Au THICKNESS PLATED
OVER 1.27-2.54 μ m NICKEL UNDERPLATED
SOLDER AREA: 1.27 μ m MIN TIN OVER 1.27-2.54 μ m NICKEL UNDERPLATED
- ELECTRICAL PERFORMANCE:
RATED CURRENT: 25A EACH POWER PIN.
INSULATION RESISTANCE: 1000M Ω MIN
- DURABILITY: 200 CYCLES.
- MATERIAL IS FULFILLED RoHS & HALOGEN FREE.
- ORDER P/N: ME10000101P1011



UNLESS OTHERWISE SPECIFIED TOLERANCES	
U.S.	METRIC
.X +/-	0.50
.XX +/-	0.25
.XXX +/-	0.15
FRACTIONS +/-	5°
ANGLES +/-	

APPROVAL		DATE
DRAWN	Yunx.liu	May.18,2020
CHECKED	LY.YI	May.18,2020
APPROVED		
DRAWING FILE :		
INTERNAL\ME\CME10000101P1011		
ANGLE OF PROJECTION		

Amphenol		
TITLE		
MINI COOL EDGE 2PIN V/T HIGH POWER CONNECTOR		
SIZE	DRAWING NO.	REV.
A3	C ME10000101P1011	3
SCALE	NONE	SHEET 1 OF 3

This document is the property of Amphenol Corporation and is delivered on the express condition that it is not to be disclosed, reproduced or used, in whole or in part, for manufacture or sale by anyone other than Amphenol Corporation without its prior consent, & that no right is granted to disclose or to use any information in this document.

CUSTOMER DRAWING

REVISIONS				
SYM	ECN	DESCRIPTION	DATE	APPROVED
		SEE SHEET 1		

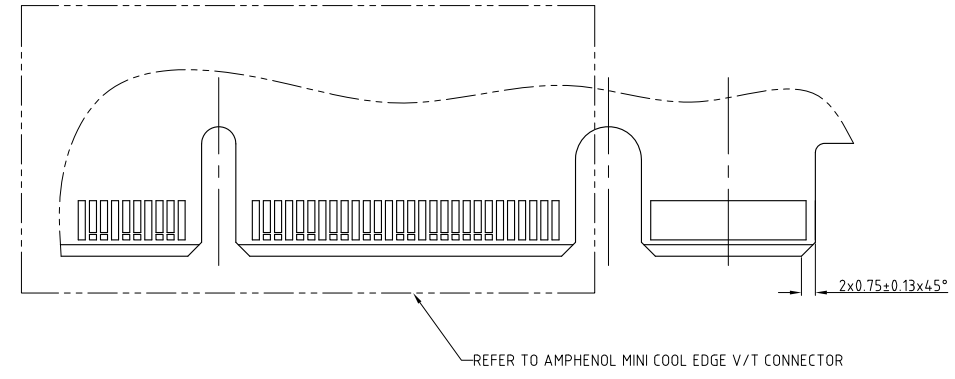
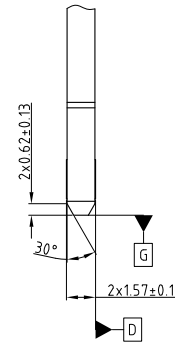
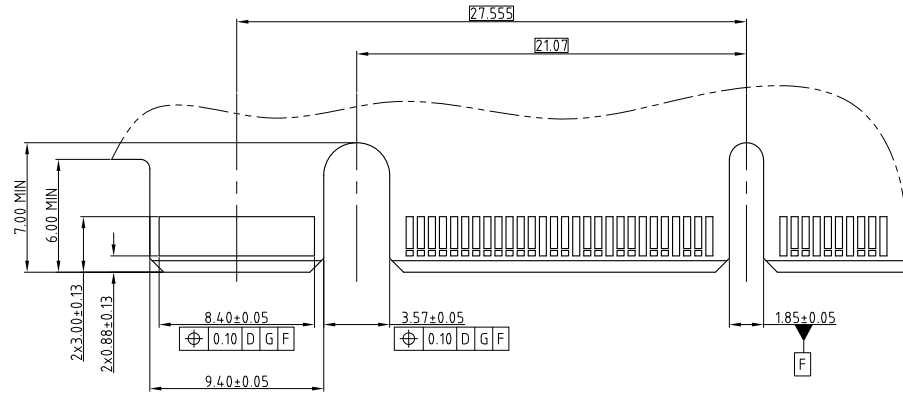

RECOMMENDED AIC MATING CARD

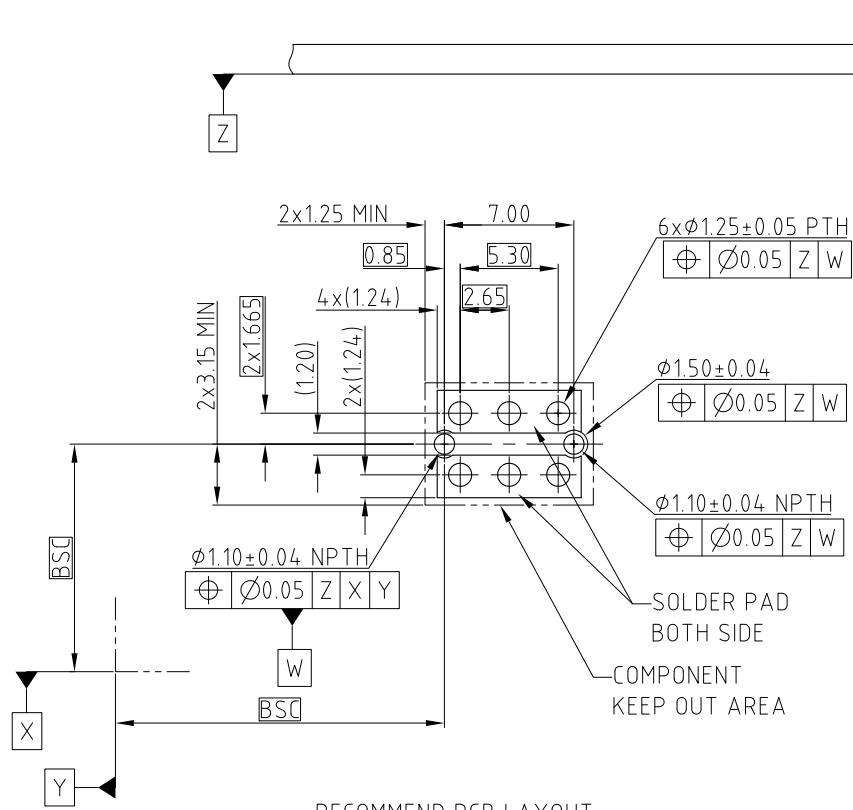

RECOMMEND PCB LAYOUT



UNLESS OTHERWISE SPECIFIED TOLERANCES	
.X +/-	U.S.
.XX +/-	METRIC
.XXX +/-	
FRACTIONS +/-	SEE SHEET 1
ANGLES +/-	
FOR MATERIALS AND FINISHES SEE NOTES	
REMOVE SHARP EDGES	
DIMENSIONS	
—U.S.—	INCHES
(METRIC)	(mm)

APPROVAL	DATE
DRAWN Yunx.liu	May.18,2020
CHECKED LY.YI	May.18,2020
APPROVED	
DRAWING FILE : INTERNAL\ME\CME10000101P1011	
ANGLE OF PROJECTION	

Amphenol		
TITLE MINI COOL EDGE 2PIN V/T HIGH POWER CONNECTOR		
SIZE A3	DRAWING NO. C ME10000101P1011	REV. 3
SCALE	NONE	SHEET 2 OF 3

This document is the property of Amphenol Corporation and is delivered on the express condition that it is not to be disclosed, reproduced or used, in whole or in part, for manufacture or sale by anyone other than Amphenol Corporation without its prior consent, & that no right is granted to disclose or to use any information in this document.

CUSTOMER DRAWING

REVISIONS				
SYM	ECN	DESCRIPTION	DATE	APPROVED
		SEE SHEET 1		

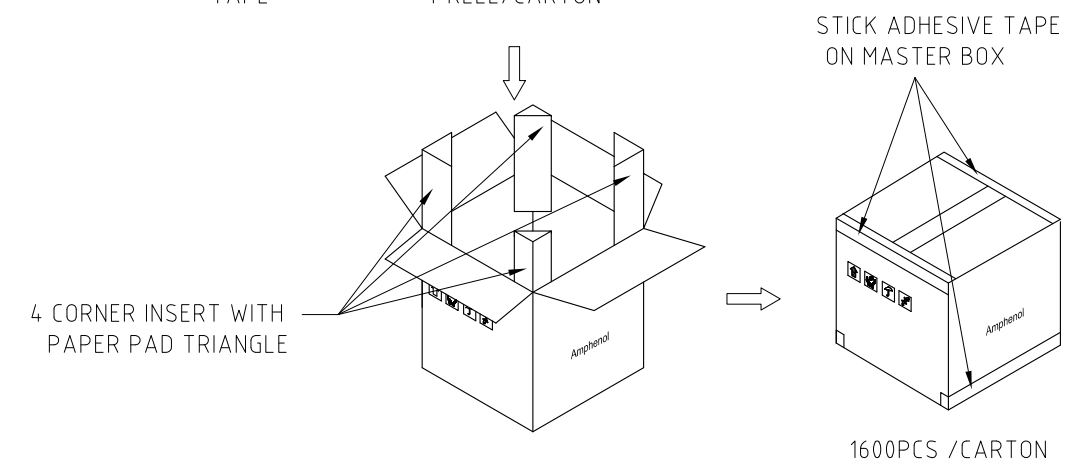
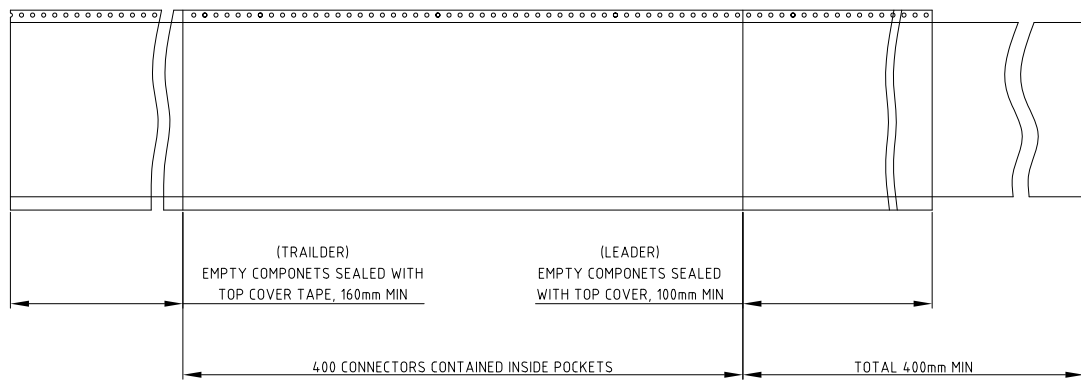
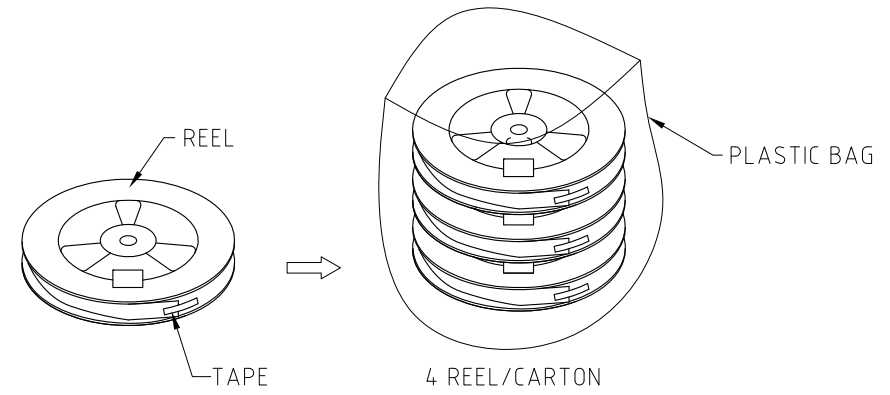
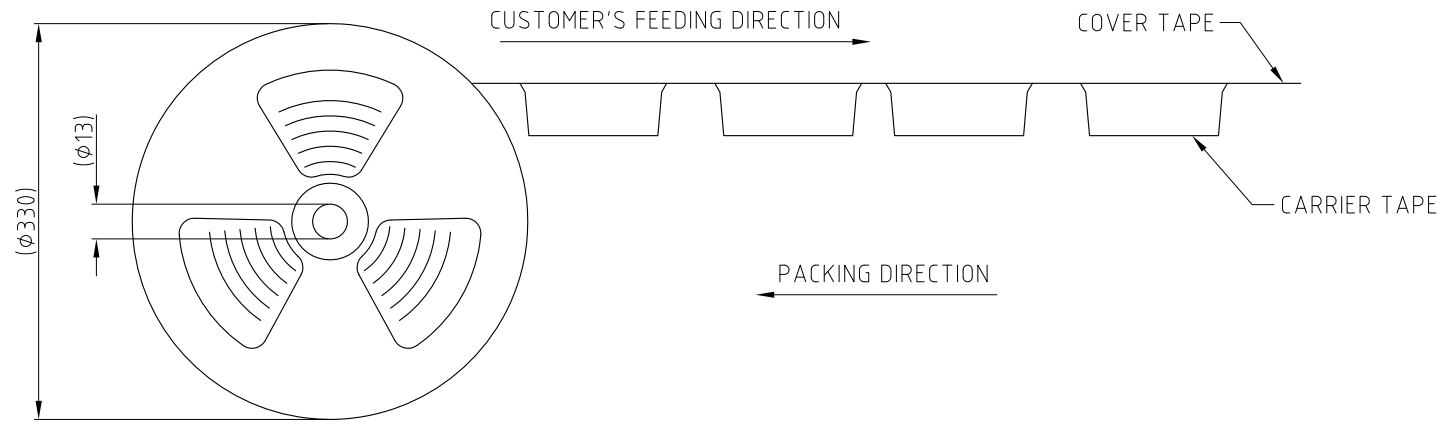
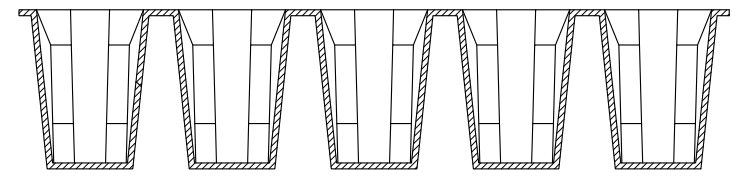
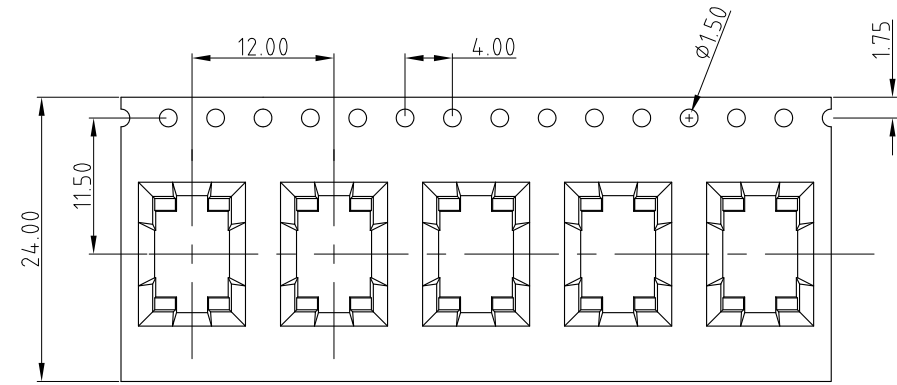
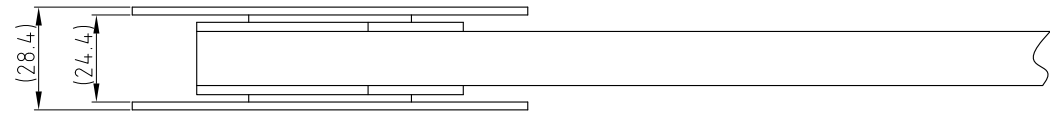

UNLESS OTHERWISE SPECIFIED TOLERANCES U.S. METRIC .X +/- .XX +/- .XXX +/- FRACTIONS +/- ANGLES +/- FOR MATERIALS AND FINISHES SEE NOTES REMOVE SHARP EDGES DIMENSIONS U.S. INCHES (METRIC) (MM)	APPROVAL	DATE
	DRAWN Yunx.liu	May.18,2020
	CHECKED Ly.yi	May.18,2020
	APPROVED	
	DRAWING FILE : INTERNAL\ME\CME10000101P1011	
ANGLE OF PROJECTION		

Amphenol		
TITLE MINI COOL EDGE 2PIN V/T HIGH POWER CONNECTOR		
SIZE A3	DRAWING NO. C ME10000101P1011	REV. 3
SCALE NONE	SHEET 3 OF 3	