

OV8856 8MP product brief



High Performance PureCel® Sensor Brings 8-Megapixel Selfies to Mainstream Smartphones



available in
a lead-free
package

OmniVision's OV8856 is a new 1/4-inch 8-megapixel PureCel sensor designed for front- and rear-facing camera applications in mainstream mobile devices. Built on advanced 1.12-micron pixel architecture, the extremely compact OV8856 offers industry-leading image quality and improved performance when compared with previous-generation 8-megapixel image sensors.

The 1/4-inch OV8856 leverages OmniVision's PureCel pixel architecture to capture full-resolution 8-megapixel images and video at 30 frames per second (fps), and 1080p high-definition (HD) video at 60 fps. The power-efficient OV8856 sensor also supports

interlaced high dynamic range (iHDR) for clear images and video in high- and low-light conditions. Using a high-speed four-lane MIPI interface, the OV8856 can output full-resolution, 8-megapixel 30 fps video over two MIPI lanes without requiring any data compression.

The OV8856 is one of the smallest 8-megapixel sensors on the market, and is approximately 15 percent smaller than OmniVision's previous-generation OV8858 image sensor. The OV8856 can fit into a 6.5 mm x 6.5 mm fixed-focus module with a z-height of approximately 4 mm.

Find out more at www.ovt.com.



OmniVision.

Applications

- Cellular Phones
- Tablets
- PC Multimedia

Product Features

- 1.12 μm x 1.12 μm pixel
- optical size of 1/4"
- 32.9° CRA for $\pm 5\text{ mm}$ Z-height
- programmable controls for:
 - frame rate
 - mirror and flip
 - cropping
 - windowing
- supports images sizes:
 - BMP (4:3, 3264x2448)
 - BMP (16:9, 3264x1836)
 - EIS 1080p (2112x1188)
 - 1080p (1920x1080)
 - EIS 720p (1408x792), and more
- 8MP at 30 fps (720 Mbps/4-lane or 1.44 Gbps/2-lane)
- two on-chip phase lock loops (PLLs)
- two-wire serial bus control (SCCB)
- 8k bits of embedded one-time programmable (OTP) memory
- image quality control:
 - defect pixel correction
 - automatic black level calibration
 - lens shading correction
 - alternate row HDR
- suitable for module size of 8.5 x 8.5 x -4 mm

OV8856



Ordering Information

- OV08856-GA4A**
(color, chip probing, 200 μm backgrinding, reconstructed wafer with good die)

Product Specifications

- active array size:** 3264 x 2448
- power supply:**
 - core: 1.14 - 1.26V (1.2V nominal)
 - analog: 2.6 - 3.0V (2.8V nominal)
 - I/O: 1.7 - 1.9V (1.8V)
- power requirements:**
 - active: 150 mW
 - standby: 0.8 μW
 - XSHUTDOWN: 1 μW
- temperature range:**
 - operating: -30°C to +85°C junction temperature
 - stable image: 0°C to +60°C junction temperature
- output interfaces:** up to 4-lane MIPI serial output
- output formats:** 10-bit RGB RAW
- lens chief ray angle:** 32.9° non-linear
- lens size:** 1/4"
- input clock frequency:** 6 - 27 MHz
- max S/N ratio:** 36.5 dB
- dynamic range:** 70 dB @ 8x gain
- maximum image transfer rate:**
 - 3264 x 2448: 30 fps
 - 3264 x 1836: 30 fps
 - 2112 x 1188: 60 fps
 - 1920 x 1080: 60 fps
 - 1408 x 792: 90 fps
- sensitivity:** 480 mV/lux-sec
- scan mode:** progressive
- pixel size:** 1.12 μm x 1.12 μm
- dark current:** 12 e⁻/sec @ 60°C junction temperature
- image area:** 3678.336 μm x 2767.68 μm
- die dimensions:**
 - COB: 4806 μm x 3969 μm
 - RW: 4856 μm x 4019 μm

Functional Block Diagram

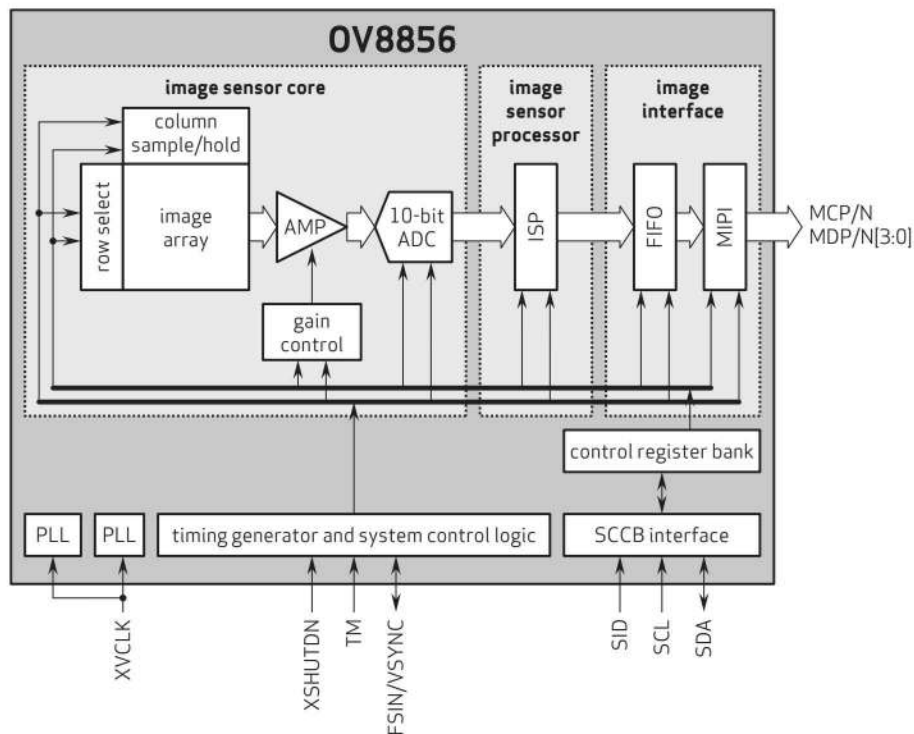

4275 Burton Drive
Santa Clara, CA 95054
USA

Tel: +1 408 567 3000
Fax: +1 408 567 3001
www.ovt.com

OmniVision reserves the right to make changes to their products or to discontinue any product or service without further notice. OmniVision, the OmniVision logo and PureCel are registered trademarks of OmniVision Technologies, Inc. All other trademarks are the property of their respective owners.



OmniVision