

PART NUMBER	REV	FIRST USED
680243-1	A	122500-1
680243-2	A	565435-5
680243-3	A	354500-1

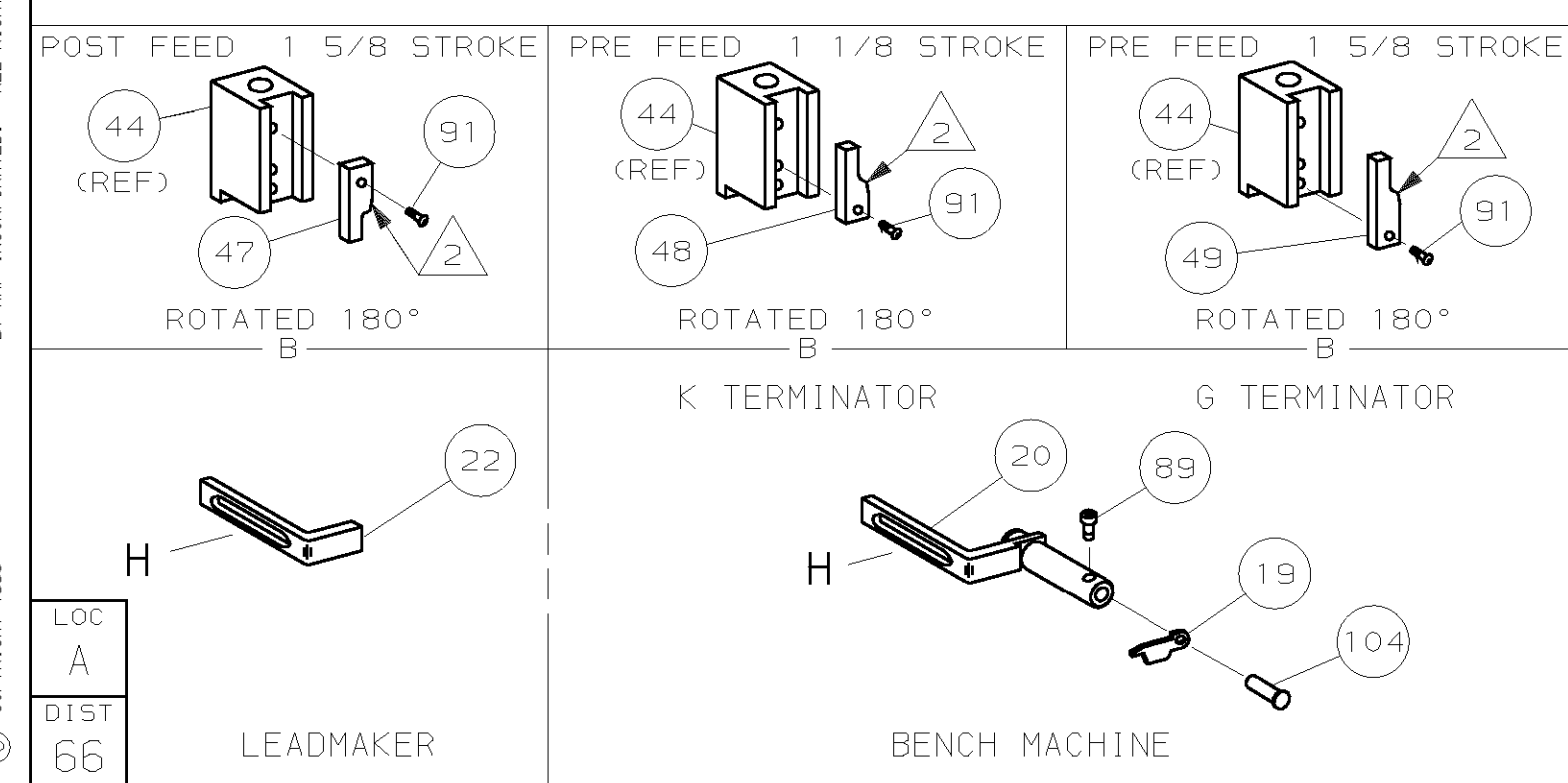
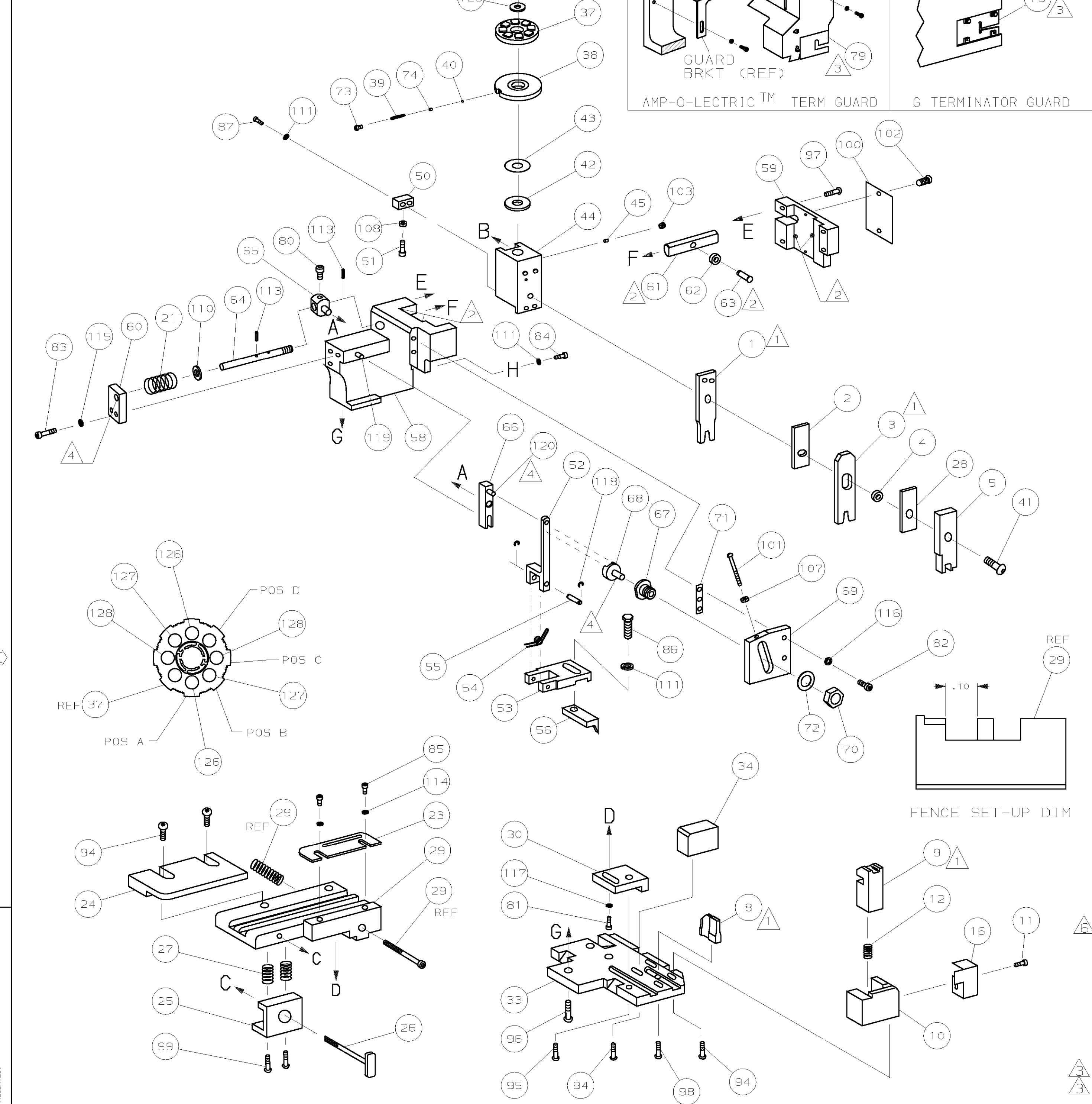

- 1 RECOMMENDED SPARE PARTS.
- 2 GREASE LIGHTLY.
- 3 GUARD MUST BE IN PLACE WHEN OPERATING APPLICATOR IN A BENCH MACHINE.
- 4 LUBRICATE DAILY USING NO. 20 MACHINE OIL.
- 5. ITEMS WITH QTY OF REF SPECIFIED (EXCEPT ITEMS 78 AND 79) ARE USED ON ITEM 46.
- 6 CUT TO LENGTH AT ASSY.
- 7 FEED ADJUSTMENT NECESSARY WHEN CHANGING TERMINALS.

TERMINAL NAME: Ø 2.5mm CONTACT SOCKET			
962858	962852		
PAD LTR	CRIMP HEIGHT	WIRE SIZE	
A	.073 ±.002 [1.85 ±0.05mm]	2.5 mm ²	
B	.067 ±.002 [1.70 ±0.05mm]	2 mm ²	
C	.061 ±.002 [1.55 ±0.05mm]	1.5 mm ²	
D	NOT	USED	
CRIMP	SIZE	TYPE	RANGE
WIRE	.100 [2.54mm]	F	1.5mm ² - 2.5mm ²
INSUL	.140 [3.56mm]	OV	2.1mm-3mm

QTY	REF	REF	REF	U/M	DWG SIZE	PART NO	DESCRIPTION	ITEM NO
2	2	2	-	C		9-354778-9	PIN, WIRE DISC (.2990)C	129
2	2	2	-	C		8-354778-7	PIN, WIRE DISC (.2930)B	127
2	2	2	-	C		7-354778-5	PIN, WIRE DISC (.2870)A	126
1	1	1	-	A		986950-1	WASHER, FLAT PRECISION	125
1	1	1	-	A		217238-1	DOCUMENTATION PACKAGE	124
1	1	1	-	-		4088040	SF APPL INST 408-8040	123
								122
								121
REF	REF	REF	-	A		1-21030-1	PIN, DOWEL (Ø.187x.50)LEVER	120
REF	REF	REF	-	A		1-21030-6	PIN, DOWEL (Ø.187x1.25)HOUSING	119
REF	REF	REF	-	A		21045-3	RING, RET "C" (Ø.187)FD FING PIN	118
1	1	1	-	A		21024-5	WASHER, LOCK (#10)ADJ BLOCK	117
REF	REF	REF	-	A		21024-5	WASHER, LOCK (#10)ADJ PLATE	116
REF	REF	REF	-	A		21024-5	WASHER, LOCK (#10)FEED GDE ROD	115
2	2	2	-	A		21024-2	WASHER, LOCK (#4)FRONT STP GUIDE	114
REF	REF	REF	-	A		5-21028-1	PIN, SLT 5PR (Ø.125x.50)ADJ ROD	113
								112
4	4	4	-	A		21024-4	WASHER, LOCK (#8)STRIPPER	111
REF	REF	REF	-	A		21899-4	WASHER, FLAT (Ø5/16)SCREW ADJ	110
								109
1	1	1	-	A		21018-5	NUT, HEX (NO. 6)HOLDDOWN	108
REF	REF	REF	-	A		21018-5	NUT, HEX (6-32)FEED ADJ	107
								106
								105
1	1	-	-	A		992031-1	PIN, CLEVIS	104
1	1	1	-	A		21009-2	SCR, 5KT SET (1/4-20x.25 LW)RAM	103
2	2	2	-	A		21017-2	SCR, DRIVE (#2x.19) ID PLATE	102
REF	REF	REF	-	A		6-23715-5	SCR, PAN HD (6-32x1.50)FEED ADJ	101
1	1	1	-	B		461264-1	PLATE, IDENTIFICATION	100
2	2	2	-	A		3-21002-0	SCR, BHC (10-32x.88)DRAG	99
1	1	1	-	A		22733-8	SCR, BHC (8-32x.38 LW)ANVIL	98
REF	REF	REF	-	A		2-21002-9	SCR, BHC (10-32x.75)CAP	97
REF	REF	REF	-	A		2-22733-8	SCR, BHC (1/4-20x.62)HOUSING	96
REF	REF	REF	-	A		2-21002-7	SCR, BHC (10-32x.50)5G ADJ BLOCK	95
6	6	6	-	A		2-21002-2	SCR, BHC (8-32x.50)TERM H DWN	94
								93
								92
1	1	1	-	A		1-21002-7	SCR, BHC (6-32x.38)CAM	91
								90
1	1	-	-	A		7-21000-9	SCR, SHC (4-40x.19)STRIPPER	89
								88
2	2	2	-	A		2-21000-7	SCR, SHC (8-32x.48)DEP-HOLD	87
1	1	1	-	A		2-22603-0	SCR, HEX HD (8-32x.31)FEED FINGER	86
2	2	2	-	A		1-21000-3	SCR, SHC (4-40x.25)F ST GUIDE	85
1	1	1	-	A		2-21000-7	SCR, SHC (8-32x.50)STRIPPER	84
REF	REF	REF	-	A		3-21000-7	SCR, SHC (10-32x.75)FEED ROD 6D	83
REF	REF	REF	-	A		3-21000-6	SCR, SHC (10-32x.62)FD ADJ BLK	82
1	1	1	-	A		3-21000-4	SCR, SHC (10-32x.38)5G ADJ BL	81
REF	REF	REF	-	A		3-21000-4	SCR, SHC (10-32x.38)PIVOT BLK	80
-	REF	-	-	B		455749-1	GUARD, WINDOW	79
REF	-	-	-	B		679532-1	INSERT, GUARD	78
								77
								75
1	1	1	-	A		690603-1	SPRING, ASSIST	74
1	1	1	-	A		23030-1	SCR, SHC (6-32x.25 SL)INS DISC	73
REF	REF	REF	-	A		458109-1	WASHER, SPECIAL	72
REF	REF	REF	-	A		690517-1	SPACER	71
-3	-2	-1	U/M	DWG SIZE				

QTY	REF	REF	REF	U/M	DWG SIZE	PART NO	DESCRIPTION	ITEM NO
1	1	1	-	A		690603-1	SPRING, ASSIST	74
1	1	1	-	A		23030-1	SCR, SHC (6-32x.25 SL)INS DISC	73
REF	REF	REF	-	A		458109-1	WASHER, SPECIAL	72
REF	REF	REF	-	A		690517-1	SPACER	71

QTY	REF	REF	REF	U/M	DWG SIZE	PART NO	DESCRIPTION	ITEM NO
-1							LEADMAKER	
-2							BENCH MODEL K	
-3							BENCH MODEL G	
REF	REF	REF	-	B		22594-8	NUT, HEX (1/2-20)	70
REF	REF	REF	-	B		240628-1	PLATE, ADJUSTMENT	69
REF	REF	REF	-	B		240626-1	SHAFT, PIVOT	68
REF	REF	REF	-	B		240633-1	BUSHING	67
REF	REF	REF	-	A		455680-1	LEVER, INTERMEDIATE	66
REF	REF	REF	-	B		240629-1	BLOCK, PIVOT	65
REF	REF	REF	-	A		240632-2	SCREW, ADJ FEED ROD	64
REF	REF	REF	-	B		240659-3	PIN, CAM ROLLER	63
REF	REF	REF	-	B		240658-1	ROLLER, CAM	62
REF	REF	REF	-	B		454398-2	ROD, FEED	61
REF	REF	REF	-	A		454178-1	GUIDE, FEED ROD	60
REF	REF	REF	-	C		454220-1	CAP, RAM	59
REF	REF	REF	-	D		454485-1	HOUSING	58
								57
1	1	1	-	B		690542-2	PAWL, FEED	56
REF	REF	REF	-	B		240624-1	PIN, FEED FINGER	55
REF	REF	REF	-	B		691499-1	SPRING, FEED FINGER	54
REF	REF	REF	-	B		690541-1	HOLDER, FEED FINGER	53
REF	REF	REF	-	A		455679-1	LEVER, TERMINAL FEED ARM	52
1	1	1	-	A		811242-2	BUMPER, HOLDDOWN	51
1	1	1	-	A		690753-1	SPACER, TONKER	50
1	-	-	-	B		690602-6	CAM, PRE-FEED 1 5/8 ST	49
-	1	-	-	B		690602-5	CAM, PRE-FEED 1 1/8 ST	48
-	-	1	-	B		690501-4	CAM, POST-FEED 1 5/8 ST	47
1	1	1	-	B		459456-1	APPLICATOR, BASIC (SUBASSY)	46
1	1	1	-	A		690191-1	PLUG, NYLON	45
1	1	1	-	C		455673-1	RAM	44
1	1	1	-	A		690125-1	WASHER, LAMINATED	43
1	1	1	-	A		690124-1	WASHER, RAM	42
1	1	1	-	A		7-21002-9	BOLT, CRIMPER (5/16x1.00)	41
1	1	1	-	A		23241-6	BALL, STEEL	40
1	1	1	-	A		690170-1	SPRING, COMPRESSION	39
1	1	1	-	C		690142-1	DISC, INSULATION	38
1	1	1	-	D		354777-1	WIRE DISC, PLASTIC	37
1	1	1	-	A		22480-5	WASHER, SPRING	36
1	1	1	-	B		690212-1	POST, RAM	35
1	1	1	-	B		2-690786-3	SUPPORT, TERMINAL	34
REF	REF	REF	-	D		455675-1	PLATE, BASE	33
								32
								31
REF	REF	REF	-	B		455689-1	BLOCK, STRIP GUIDE ADJ	30
1	1	1	-	C		318756-1	STRIP GUIDE PLATE ASSY	29
1	1	1	-	C		2-455888-2	SPACER, FRONT SHEAR DEP	28
2	2	2	-	A		1-22284-0	SPRING, DRAG	27
1	1	1	-	B		690546-1	LEVER, DRAG RELEASE	26
1	1	1	-	B		240792-1	DRAG, TERMINAL	25
1	1	1	-	D		90765-1	GUIDE, STRIP (REAR)	24
1	1	1	-	A		690438-1	GUIDE, STRIP (FRONT)	23
-	-	1	-	B		690472-2	STRIPPER	22
REF	REF	REF	-	A		4-22284-9	SPRING, FEED RETURN	21
1	1	-	-	A		679218-1	STRIPPER WIRE STOP ASSY	20
1	1	-	-	B		458949-1	STRIPPER	19
								18
								17
1	1	1	-	B		318563-1	GUARD, CHIP, FRONT	16
								15
								14
								13
1	1	1	-	A		5-22280-0	SPRING, SHEAR	12
1	1	1	-	B		690461-1	STOP, SHEAR	11
1	1	1	-	C		690459-1	HOLDER, SHEAR (FRONT)	10
1	1	1	-	C		1-454276-9	SHEAR, FLOAT (FRONT)	9
1	1	1	-	C		5-189717-9	ANVIL	8
								7
								6
1	1	1	-	C		1-455889-4	DEPRESSOR, SHEAR (FRONT)	5
1	1	1	-	B		2-238011-2	SPACER, BLOCK CRIMPER	4
1	1	1	-	C		1-854830-0	CRIMPER, INSULATION	3
1	1	1	-	C		455888-8	SPACER, CRIMPER	2
1	1	1	-	C		456407-8	CRIMPER, WIRE	1

QTY	REF	REF	REF	U/M	DWG SIZE	PART NO	DESCRIPTION	ITEM NO
-3	-2	-1	U/M	DWG SIZE				