

Precision SOT-23 FGA™ Voltage References

The X60003 FGA™ voltage reference is a very high precision analog voltage reference fabricated in Intersil's proprietary Floating Gate Analog technology, which achieves superior levels of performance when compared to conventional band gap, buried zener, or X_{FET}™ technologies.

FGA™ voltage references feature very high initial accuracy, very low temperature coefficient, excellent long term stability, low noise and excellent line and load regulation, at the lowest power consumption currently available. These voltage references enable advanced applications for precision industrial and portable systems operating at significantly higher accuracy and lower power levels than can be achieved with conventional technologies.

Available Options

PART NUMBER	V _{OUT} OPTION (V)	INITIAL ACCURACY (mV)	TEMPCO. (ppm/°C)
X60003BIG3-41T1	4.096	±1.0	10
X60003BIG3Z-41T1	4.096	±1.0	10
X60003CIG3-41T1	4.096	±2.5	20
X60003CIG3Z-41T1	4.096	±2.5	20
X60003DIG3-41T1	4.096	±5.0	20
X60003DIG3Z-41T1	4.096	±5.0	20
X60003BIG3-50T1	5.000	±1.0	10
X60003BIG3Z-50T1	5.000	±1.0	10
X60003CIG3-50T1	5.000	±2.5	20
X60003CIG3Z-50T1	5.000	±2.5	20
X60003DIG3-50T1	5.000	±5.0	20
X60003DIG3Z-50T1	5.000	±5.0	20

Pinout

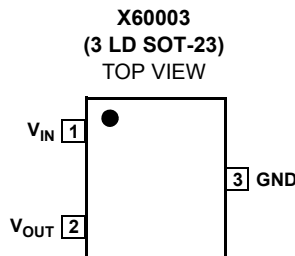

Features

- Reference Output Voltage 4.096V, 5.000V
- Initial Accuracy ±1.0mV (B grade)
- Ultra Low Power Supply Current 500nA
- Low Temperature Coefficient (B Grade) 10ppm/°C
- 10mA Source and Sink Current Capability
- Very Low Dropout Voltage 100mV at No Load
- Input Voltage Range
 - X60003-41 4.5V to 9.0V
 - X60003-50 5.1V to 9.0V
- 5kV ESD (Human Body Model)
- Standard Package 3 Ld SOT-23
- Temp Range -40°C to +85°C
- Pb-Free Available (RoHS Compliant)

Applications

- High Resolution A/Ds and D/As
- Digital Meters
- Calibration Systems
- V-F Converters
- Precision Current Sources
- Precision Regulators
- Precision Oscillators
- Smart Sensors
- Strain Gage Bridges
- Threshold Detectors
- Battery Management Systems
- Servo Systems

Pin Descriptions

PIN NUMBER	PIN NAME	DESCRIPTION
1	VIN	Power Supply Input Connection
2	VOUT	Voltage Reference Output Connection
3	GND	Ground Connection

Ordering Information

PART NUMBER	PART MARKING	V _{OUT} (V)	GRADE	TEMP. RANGE (°C)	PACKAGE (Tape and Reel)	PKG. DWG #
X60003BIG3-41T1*	AID	4.096	±1.0mV, 10ppm/°C	-40 to +85	3 Ld SOT-23	P3.064
X60003BIG3Z-41T1* (Note)	APF		±1.0mV, 10ppm/°C	-40 to +85	3 Ld SOT-23 (Pb-free)	P3.064
X60003CIG3-41T1*	AIE		±2.5mV, 20ppm/°C	-40 to +85	3 Ld SOT-23	P3.064
X60003CIG3Z-41T1* (Note)	APH		±2.5mV, 20ppm/°C	-40 to +85	3 Ld SOT-23 (Pb-free)	P3.064
X60003DIG3-41T1*	AIF		±5.0mV, 20ppm/°C	-40 to +85	3 Ld SOT-23	P3.064
X60003DIG3Z-41T1* (Note)	APJ		±5.0mV, 20ppm/°C	-40 to +85	3 Ld SOT-23 (Pb-free)	P3.064
X60003BIG3-50T1*	AHA	5.00	±1.0mV, 10ppm/°C	-40 to +85	3 Ld SOT-23	P3.064
X60003BIG3Z-50T1* (Note)	APG		±1.0mV, 10ppm/°C	-40 to +85	3 Ld SOT-23 (Pb-free)	P3.064
X60003CIG3-50T1*	AHB		±2.5mV, 20ppm/°C	-40 to +85	3 Ld SOT-23	P3.064
X60003CIG3Z-50T1* (Note)	API		±2.5mV, 20ppm/°C	-40 to +85	3 Ld SOT-23 (Pb-free)	P3.064
X60003DIG3-50T1*	AHC		±5.0mV, 20ppm/°C	-40 to +85	3 Ld SOT-23	P3.064
X60003DIG3Z-50T1* (Note)	APK		±5.0mV, 20ppm/°C	-40 to +85	3 Ld SOT-23 (Pb-free)	P3.064

*Please refer to TB347 for details on reel specifications.

NOTE: These Intersil Pb-free plastic packaged products employ special Pb-free material sets, molding compounds/die attach materials, and 100% matte tin plate plus anneal (e3 termination finish, which is RoHS compliant and compatible with both SnPb and Pb-free soldering operations). Intersil Pb-free products are MSL classified at Pb-free peak reflow temperatures that meet or exceed the Pb-free requirements of IPC/JEDEC J STD-020.

Typical Application Circuit

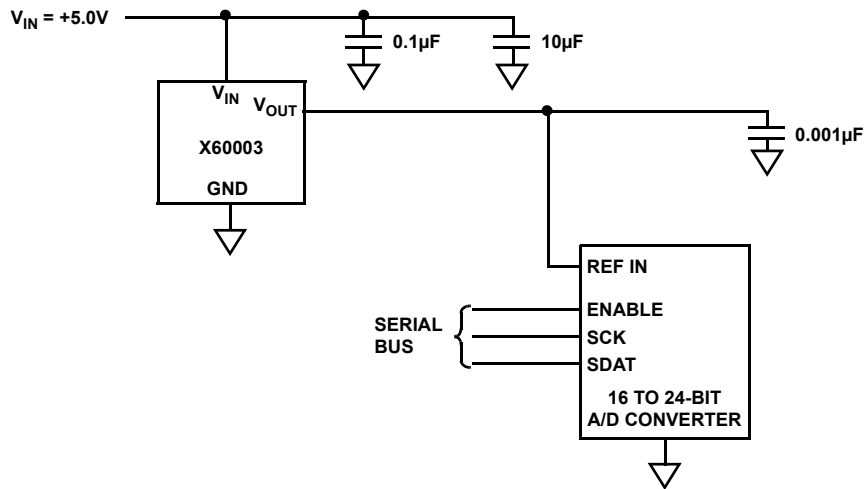

FIGURE 1. TYPICAL APPLICATION PRECISION 16 TO 24-BIT A/D CONVERTER

X60003

Absolute Voltage Ratings

Storage Temperature Range -65°C to +125°C
 Max Voltage Applied
 V_{IN} to GND -0.5V to +10V
 V_{OUT} to GND (10s). -0.5V to +5.1V
 ESD Rating
 Human Body Model (HBM) 5kV

Thermal Information

Thermal Resistance (Typical, Note 1) θ_{JA} (°C/W)
 3 Lead SOT-23 202.70
 Pb-free reflow profile (Note 2). see link below
<http://www.intersil.com/pbfree/Pb-FreeReflow.asp>

Recommended Operating Conditions

Temperature Range (Industrial) -40°C to +85°C

CAUTION: Do not operate at or near the maximum ratings listed for extended periods of time. Exposure to such conditions may adversely impact product reliability and result in failures not covered by warranty.

IMPORTANT NOTE: All parameters having Min/Max specifications are guaranteed. Typ values are for information purposes only. Unless otherwise noted, all tests are at the specified temperature and are pulsed tests, therefore: T_J = T_C = T_A

NOTES:

1. θ_{JA} is measured with the component mounted on a high effective thermal conductivity test board in free air. See Tech Brief TB379 for details.
2. Post-reflow drift for the X60003 devices will range from 100µV to 1.0mV based on experimental results with devices on FR4 double sided boards. The design engineer must take this into account when considering the reference voltage after assembly.

Common Electrical Specifications Operating Conditions: I_{OUT} = 0mA, C_{OUT} = 0.001µF, T_A = -40 to +85°C

SYMBOL	PARAMETER	CONDITIONS	MIN	TYP	MAX	UNITS
V _{OA}	V _{OUT} Accuracy @ T _A = +25°C	X60003B	-1.0		+1.0	mV
		X60003C	-2.5		+2.5	mV
		X60003D	-5.0		+5.0	mV
I _{IN}	Supply Current		500	900	nA	
TC V _{OUT}	Output Voltage Temperature Coefficient (Note 3)	X60003B			10	ppm/°C
		X60003C			20	ppm/°C
		X60003D			20	ppm/°C
V _N	Output Voltage Noise	0.1Hz to 10Hz		30		µV _{P-P}
I _{SC}	Short Circuit Current	T _A = +25°C		50	80	mA

Electrical Specifications (X60003-41) V_{IN} = 5.0, T_A = -40°C to +85°C, unless otherwise specified.

SYMBOL	PARAMETER	CONDITIONS	MIN	TYP	MAX	UNITS
V _{IN}	Input Voltage Range		4.5		9.0	V
V _{OUT}	Output Voltage			4.096		V
ΔV _{OUT} /ΔV _{IN}	Line Regulation	+4.5V ≤ V _{IN} ≤ +8.0V			150	µV/V
ΔV _{OUT} /ΔI _{OUT}	Load Regulation	Sourcing: 0mA ≤ I _{SOURCE} ≤ 10mA		10	50	µV/mA
		Sinking: -10mA ≤ I _{SINK} ≤ 0mA		20	100	µV/mA
ΔV _{OUT} /ΔT _A	Thermal Hysteresis (Note 4)	ΔT = -40°C to +85°C		150		ppm
ΔV _{OUT} /Δt	Long Term Stability (Note 5)	T _A = +25°C		50		ppm

Electrical Specifications (X60003-50) $V_{IN} = 6.5V$, $T_A = -40^{\circ}C$ to $+85^{\circ}C$, unless otherwise specified.

SYMBOL	PARAMETER	CONDITIONS	MIN	TYP	MAX	UNITS
V_{IN}	Input Voltage Range		5.1		9.0	V
V_{OUT}	Output Voltage			5.000		V
$\Delta V_{OUT}/\Delta V_{IN}$	Line Regulation	$+5.5V \leq V_{IN} \leq +8.0V$			150	$\mu V/V$
$\Delta V_{OUT}/\Delta I_{OUT}$	Load Regulation	Sourcing: $0mA \leq I_{SOURCE} \leq 10mA$		10	50	$\mu V/mA$
		Sinking: $-10mA \leq I_{SINK} \leq 0mA$		20	100	$\mu V/mA$
V_{DO}	Dropout Voltage	$I_{OUT} = 5mA$, $\Delta V_{OUT} = -0.01\%$		150	300	mV
$\Delta V_{OUT}/\Delta T_A$	Thermal Hysteresis (Note 4)	$\Delta T = -40^{\circ}C$ to $+85^{\circ}C$		100		ppm
$\Delta V_{OUT}/\Delta t$	Long Term Stability (Note 5)	$T_A = +25^{\circ}C$		45		ppm

NOTES:

- Over the specified temperature range. Temperature coefficient is measured by the box method whereby the change in V_{OUT} is divided by the temperature range; in this case, $-40^{\circ}C$ to $+85^{\circ}C = +125^{\circ}C$.
- Thermal Hysteresis is the change of V_{OUT} measured at $T_A = +25^{\circ}C$ after temperature cycling over a specified range, ΔT_A . V_{OUT} is read initially at $T_A = +25^{\circ}C$ for the device under test. The device is temperature cycled and a second V_{OUT} measurement is taken at $+25^{\circ}C$. The difference between the initial V_{OUT} reading and the second V_{OUT} reading is then expressed in ppm. For $\Delta T_A = +125^{\circ}C$, the device under test is cycled from $+25^{\circ}C$ to $+85^{\circ}C$ to $-40^{\circ}C$ to $+85^{\circ}C$.
- Long term drift is logarithmic in nature and diminishes over time. Drift after the first 1000 hours will be approximately $10ppm/\sqrt{1kHrs}$

Typical Performance Curves (X60003-41) $V_{IN} = 5.0V$, $I_{OUT} = 0mA$, $T_A = +25^{\circ}C$ unless otherwise specified.

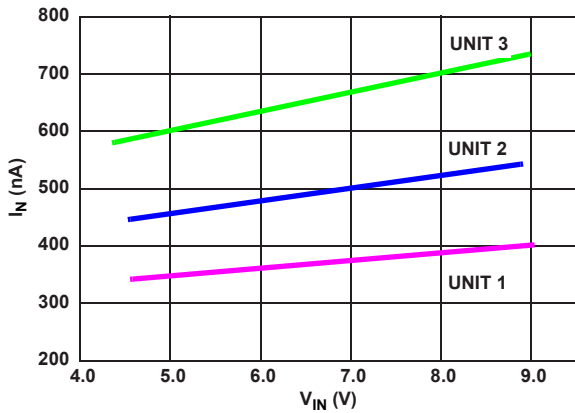

FIGURE 2. I_{IN} vs V_{IN} (3 UNITS)

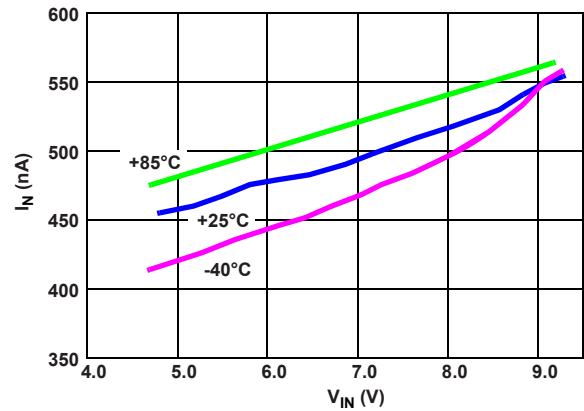

FIGURE 3. I_{IN} vs V_{IN}

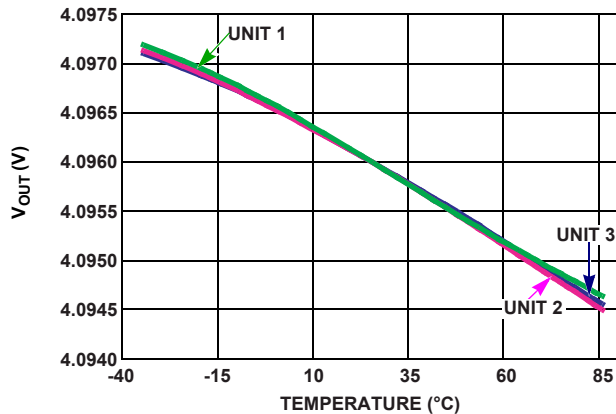

FIGURE 4. V_{OUT} vs TEMPERATURE NORMALIZED TO $+25^{\circ}C$ (3 UNITS)

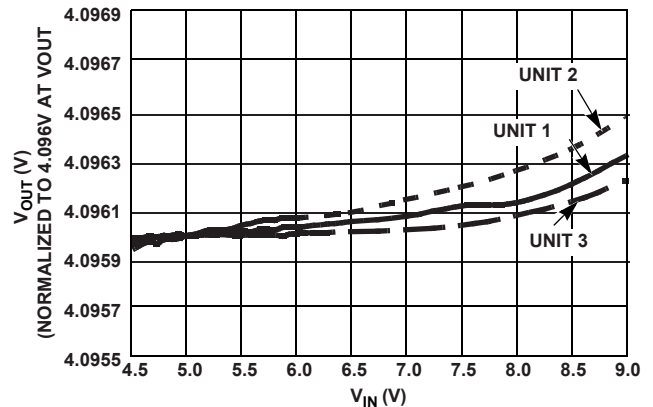

FIGURE 5. LINE REGULATION (3 UNITS)

Typical Performance Curves (X60003-41) $V_{IN} = 5.0V$, $I_{OUT} = 0mA$, $T_A = +25^\circ C$ unless otherwise specified. (Continued)

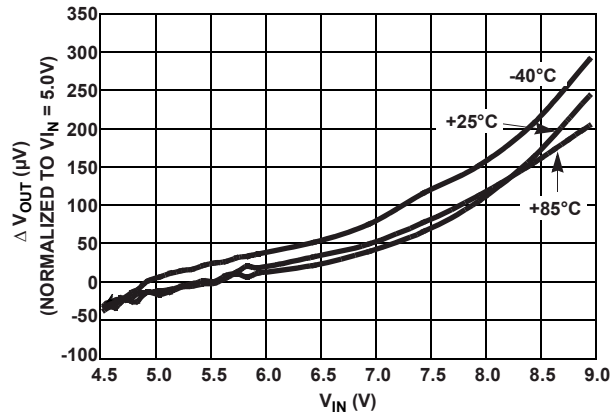

FIGURE 6. LINE REGULATION OVER-TEMPERATURE

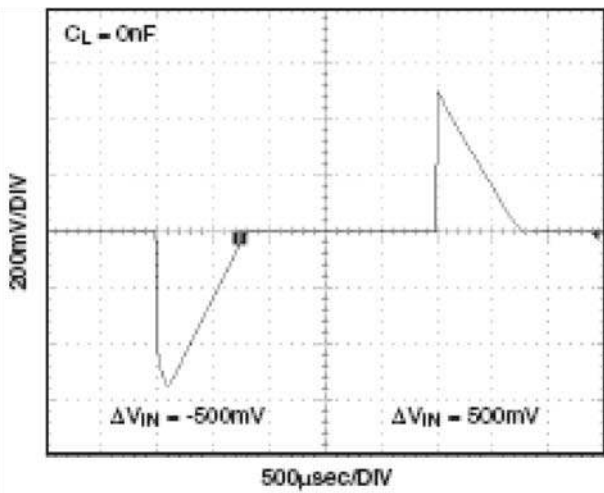

FIGURE 7. LINE TRANSIENT RESPONSE, NO CAPACITIVE LOAD

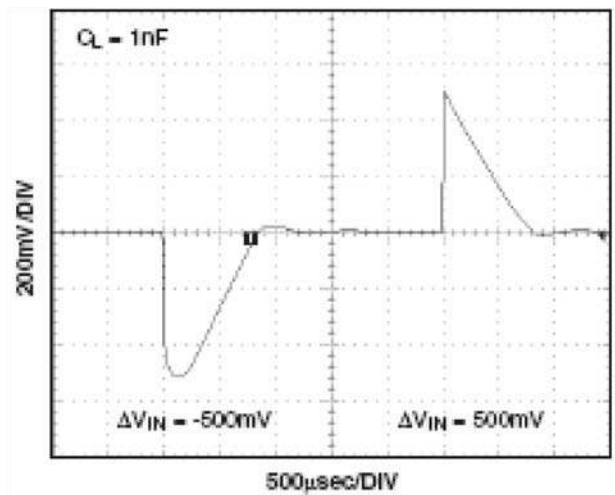

FIGURE 8. LINE TRANSIENT RESPONSE, 0.001 μF LOAD CAPACITANCE

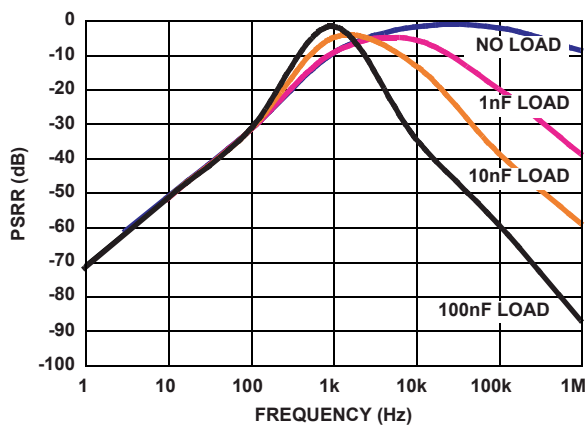

FIGURE 9. PSRR vs CAP LOAD

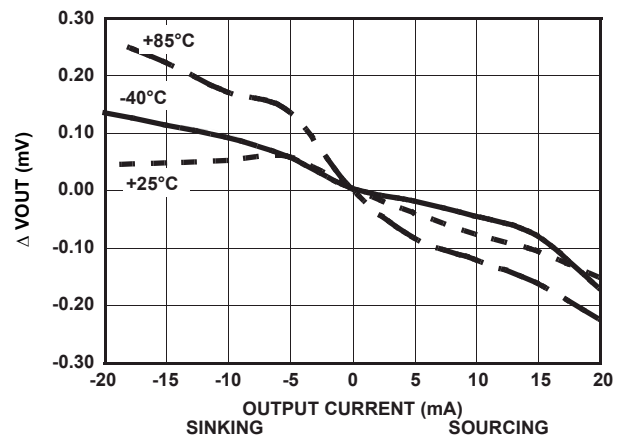

FIGURE 10. LOAD REGULATION

Typical Performance Curves (X60003-41) $V_{IN} = 5.0V$, $I_{OUT} = 0mA$, $T_A = +25^\circ C$ unless otherwise specified. (Continued)

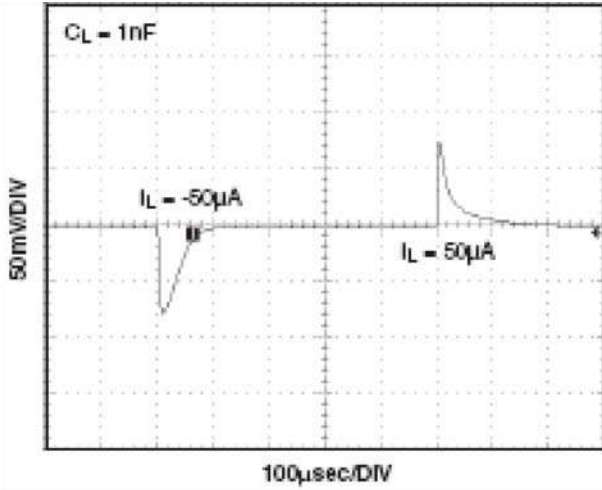

FIGURE 11. LOAD TRANSIENT RESPONSE

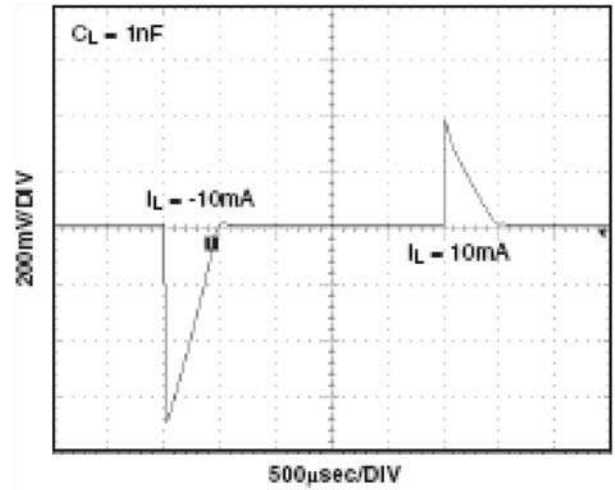

FIGURE 12. LOAD TRANSIENT RESPONSE

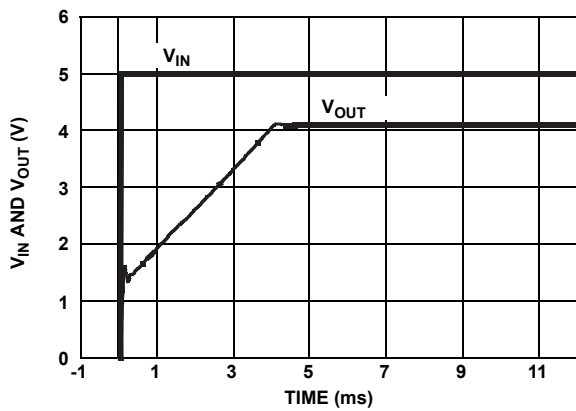

FIGURE 13. TURN-ON TIME (+25°C)

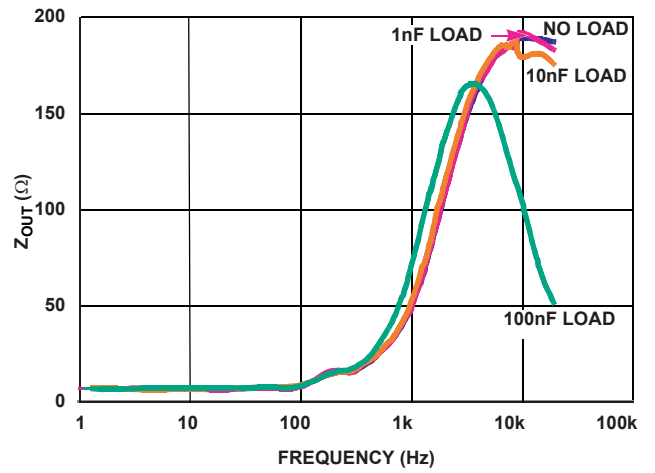

FIGURE 14. Z_{OUT} vs FREQUENCY

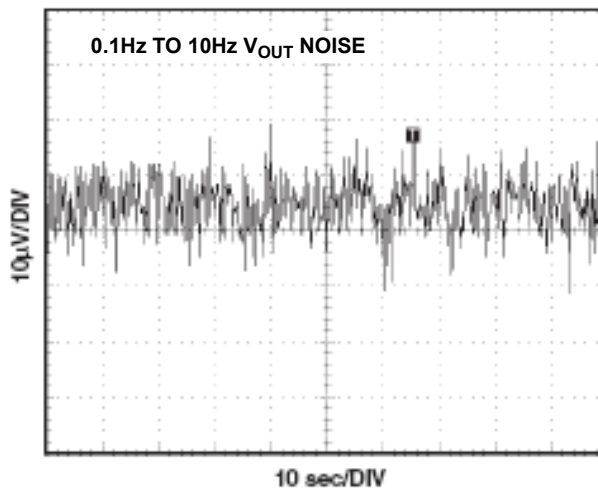

FIGURE 15. BAND PASS FILTER WITH ZERO AT 0.1Hz AND 2 POLES AT 10Hz

Typical Performance Curves (X60003-50) ($V_{IN} = 6.5V$, $I_{OUT} = 0mA$, $T_A = +25^\circ C$ unless otherwise specified)

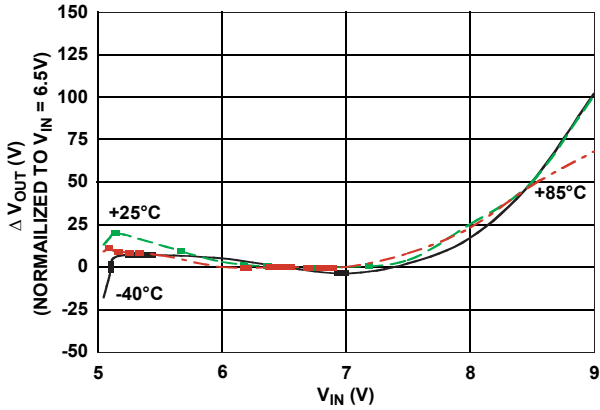

FIGURE 16. LINE REGULATION

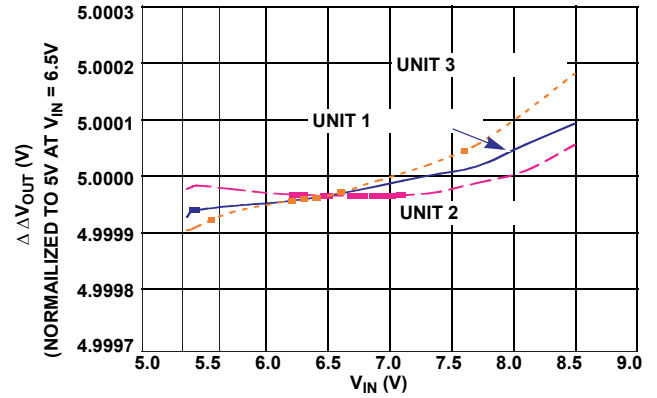

FIGURE 17. LINE REGULATION (3 UNITS)

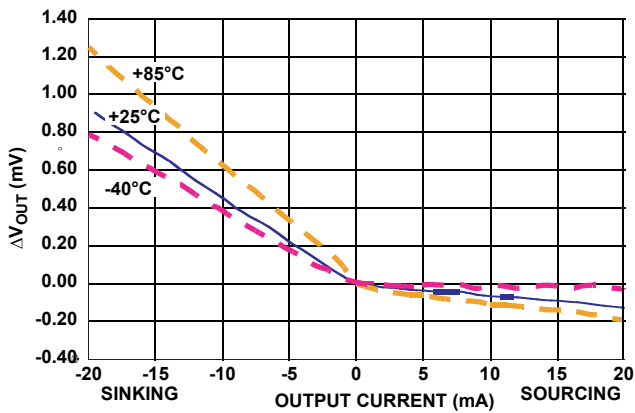

FIGURE 18. LOAD REGULATION OVER TEMPERATURE

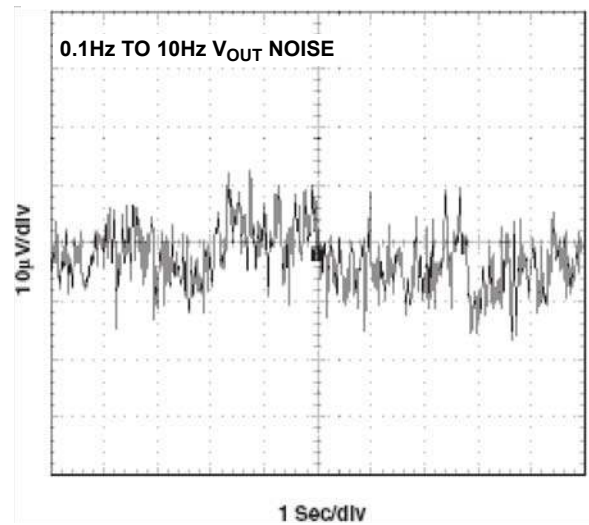

FIGURE 19. BAND PASS FILTER WITH ZERO AT 0.1Hz AND 2 POLES AT 10Hz

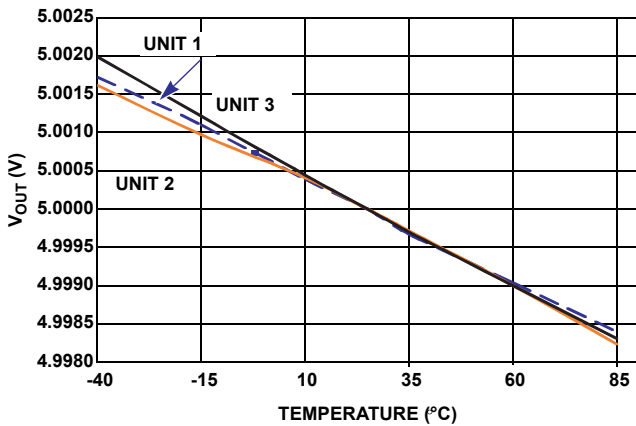

FIGURE 20. V_{OUT} vs TEMPERATURE (3 UNITS)

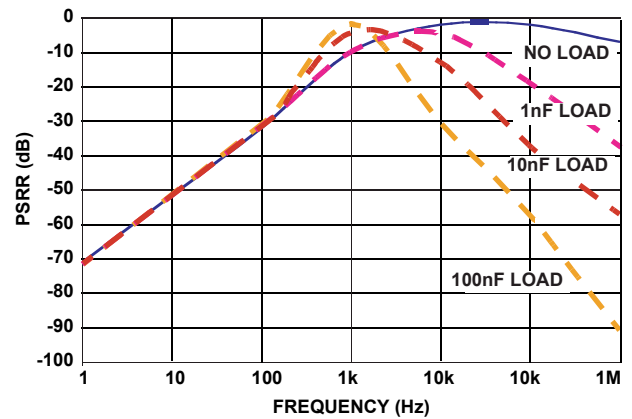

FIGURE 21. PSRR vs CAP LOAD

Typical Performance Curves (X60003-50) ($V_{IN} = 6.5V$, $I_{OUT} = 0mA$, $T_A = +25^\circ C$ unless otherwise specified) (Continued)

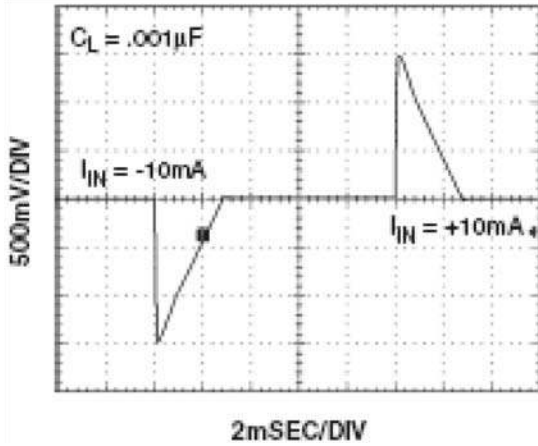

FIGURE 22. 10mA LOAD TRANSIENT RESPONSE

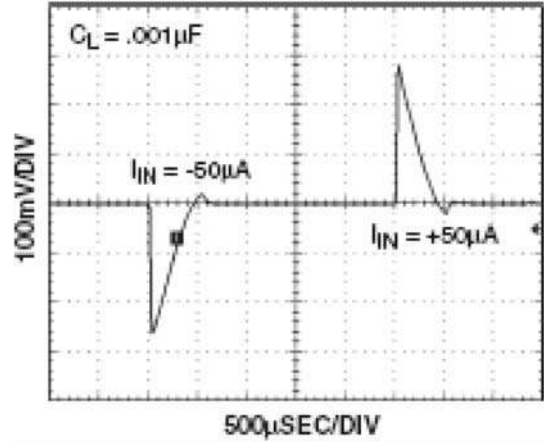

FIGURE 23. 50µA LOAD TRANSIENT RESPONSE

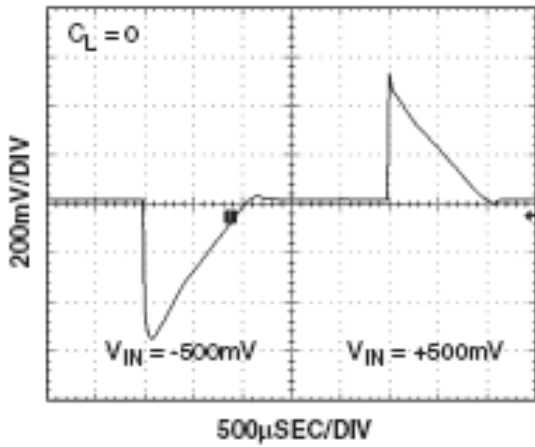

FIGURE 24. LINE TRANSIENT RESPONSE

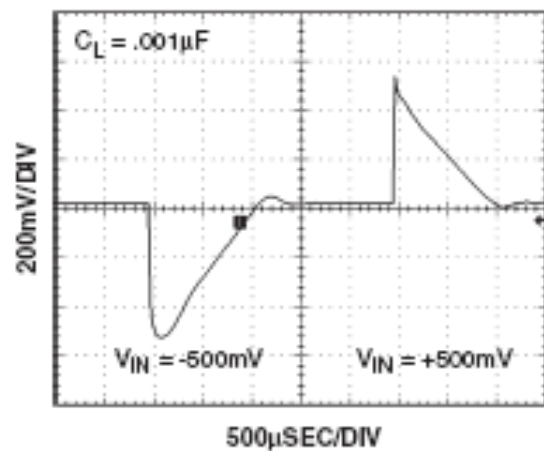

FIGURE 25. LINE TRANSIENT RESPONSE

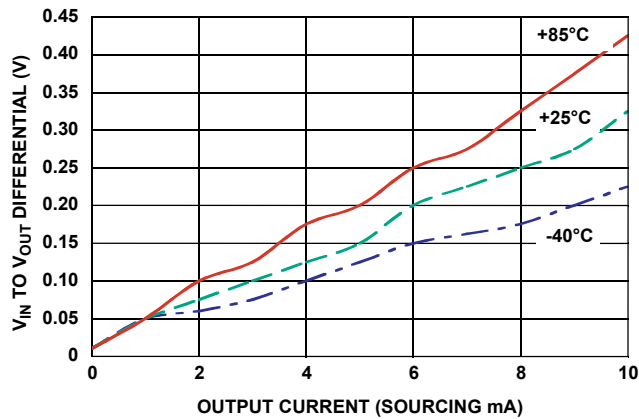

FIGURE 26. MINIMUM V_{IN} TO V_{OUT} DIFFERENTIAL vs OUTPUT CURRENT

Typical Performance Curves (X60003-50) ($V_{IN} = 6.5V$, $I_{OUT} = 0mA$, $T_A = +25^\circ C$ unless otherwise specified) (Continued)

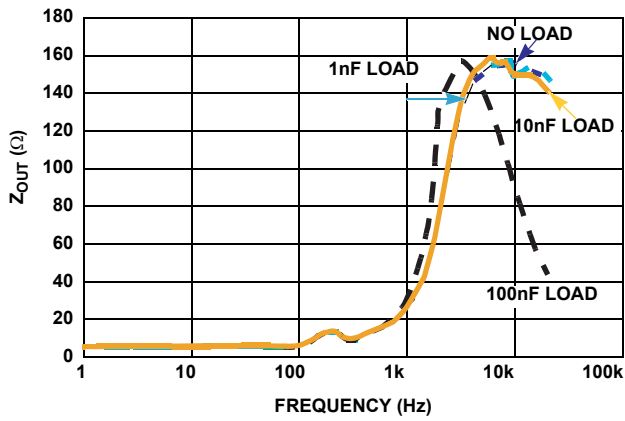

FIGURE 27. Z_{OUT} vs FREQUENCY

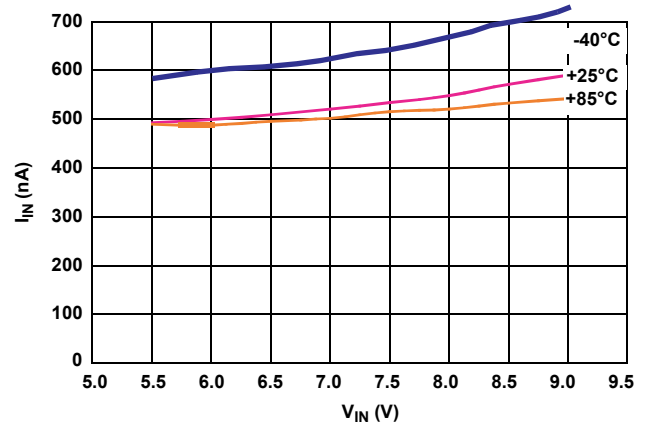

FIGURE 28. I_{IN} vs V_{IN}

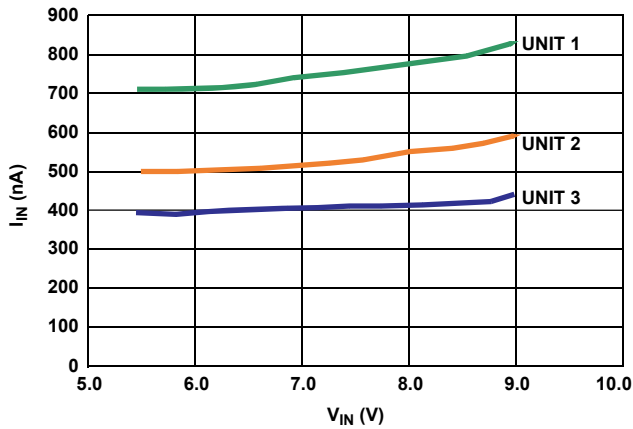

FIGURE 29. I_{IN} vs V_{IN} (3 UNITS)

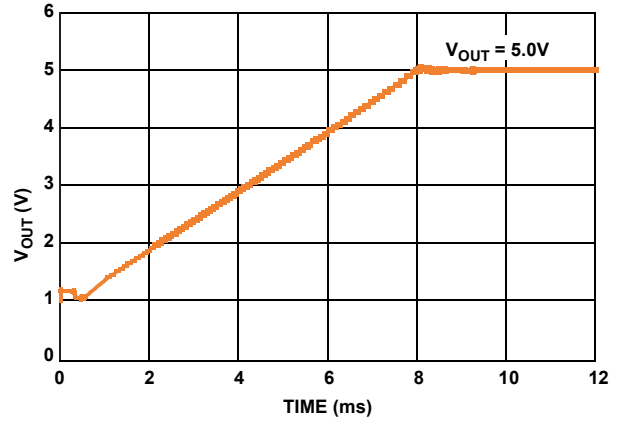

FIGURE 30. TURN-ON TIME

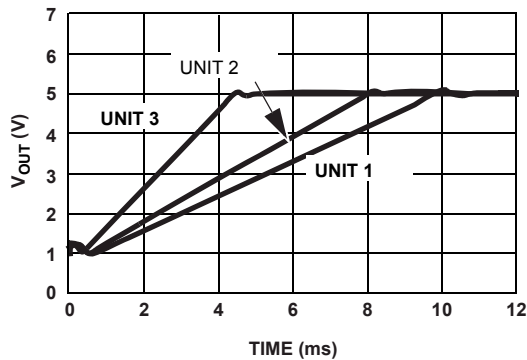

FIGURE 31. X60003 TURN-ON TIME (+25°C), 3 UNITS

Applications Information

FGA Technology

The X60003 voltage references use the floating gate technology to create references with very low drift and supply current. Essentially the charge stored on a floating gate cell is set precisely in manufacturing. The reference voltage output itself is a buffered version of the floating gate voltage. The resulting reference device has excellent characteristics which are unique in the industry: very low temperature drift, high initial accuracy, and almost zero supply current. Also, the reference voltage itself is not limited by voltage bandgaps or zener settings, so a wide range of reference voltages can be programmed (standard voltage settings are provided, but customer-specific voltages are available).

The process used for these reference devices is a floating gate CMOS process, and the amplifier circuitry uses CMOS transistors for amplifier and output transistor circuitry. While providing excellent accuracy, there are limitations in output noise level and load regulation due to the MOS device characteristics. These limitations are addressed with circuit techniques discussed in other sections.

Nanopower Operation

Reference devices achieve their highest accuracy when powered up continuously, and after initial stabilization has taken place.

The X60003 is the first high precision voltage references with ultra low power consumption that makes it practical to leave power-on continuously in battery operated circuits. The X60003 consume extremely low supply current due to the proprietary FGA technology. Supply current at room temperature is typically 500nA which is 1 to 2 orders of magnitude lower than competitive devices. Application circuits using battery power will benefit greatly from having an accurate, stable reference which essentially presents no load to the battery.

In particular, battery-powered data converter circuits that would normally require the entire circuit to be disabled when not in use can remain powered-up between conversions as shown in Figure 32. Data acquisition circuits providing 12 to 24-bits of accuracy can operate with the reference device continuously biased with no power penalty, providing the highest accuracy and lowest possible long term drift.

Other reference devices consuming higher supply currents will need to be disabled in between conversions to conserve battery capacity. Absolute accuracy will suffer as the device is biased and requires time to settle to its final value, or, may not actually settle to a final value as power-on time may be short.

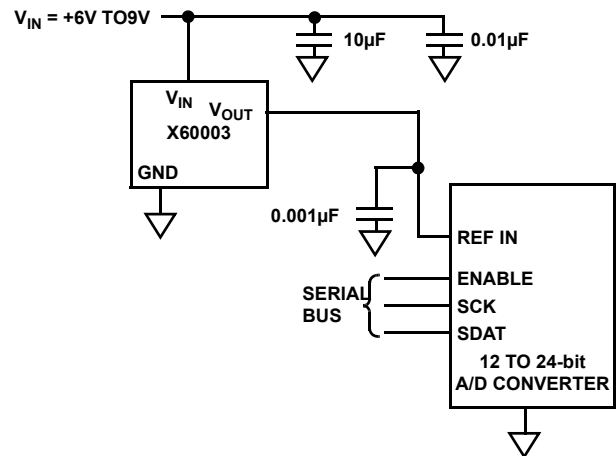

FIGURE 32. BATTERY-POWERED DATA CONVERTER CIRCUITS

Board Mounting Considerations

For applications requiring the highest accuracy, board mounting location should be reviewed. Placing the device in areas subject to slight twisting can cause degradation of the accuracy of the reference voltage due to die stresses. It is normally best to place the device near the edge of a board, or the shortest side, as the axis of bending is most limited at that location. Obviously mounting the device on flexprint or extremely thin PC material will likewise cause loss of reference accuracy.

Board Assembly Considerations

FGA references provide high accuracy and low temperature drift but some PC board assembly precautions are necessary. Normal Output voltage shifts of 100µV to 1mV can be expected with Pb-free reflow profiles or wave solder on multi-layer FR4 PC boards. Precautions should be taken to avoid excessive heat or extended exposure to high reflow or wave solder temperatures, this may reduce device initial accuracy.

Post-assembly x-ray inspection may also lead to permanent changes in device output voltage and should be minimized or avoided. If x-ray inspection is required, it is advisable to monitor the reference output voltage to verify excessive shift has not occurred. If large amounts of shift are observed, it is best to add an X-ray shield consisting of thin zinc (300µm) sheeting to allow clear imaging, yet block x-ray energy that affects the FGA reference.

Special Applications Considerations

In addition to post-assembly examination, there are also other X-ray sources that may affect the FGA reference long term accuracy. Airport screening machines contain X-rays and will have a cumulative effect on the voltage reference output accuracy. Carry-on luggage screening uses low level X-rays and is not a major source of output voltage shift, although if a product is expected to pass through that type of screening over 100 times it may need to consider shielding with copper or aluminum. Checked luggage X-rays are higher intensity and can cause output voltage shift in much fewer passes, so devices expected to go through those machines should definitely consider shielding. Note that just two layers of 1/2 ounce copper planes will reduce the received dose by over 90%. The leadframe for the device which is on the bottom also provides similar shielding.

If a device is expected to pass through luggage X-ray machines numerous times, it is advised to mount a 2-layer (minimum) PC board on the top, and along with a ground plane underneath will effectively shield it from from 50 to 100 passes through the machine. Since these machines vary in X-ray dose delivered, it is difficult to produce an accurate maximum pass recommendation.

Noise Performance and Reduction

The output noise voltage in a 0.1Hz to 10Hz bandwidth is typically $30\mu V_{P-P}$. This is shown in the plot in the “Typical Performance Curves” on page 6 and 7. The noise measurement is made with a bandpass filter made of a 1-pole high-pass filter with a corner frequency at 0.1Hz and a 2-pole low-pass filter with a corner frequency at 12.6Hz to create a filter with a 9.9Hz bandwidth. Noise in the 10kHz to 1MHz bandwidth is approximately $400\mu V_{P-P}$ with no capacitance on the output, as shown in Figure 33. These noise measurements are made with a 2 decade bandpass filter made of a 1-pole high-pass filter with a corner frequency at 1/10 of the center frequency and 1-pole low-pass filter with a corner frequency at 10x the center frequency. Figure 33 also shows the noise in the 10kHz to 1MHz band can be reduced to about $50\mu V_{P-P}$ using a $0.001\mu F$ capacitor on the output. Noise in the 1kHz to 100kHz band can be further reduced using a $0.1\mu F$ capacitor on the output, but noise in the 1Hz to 100Hz band increases due to instability of the very low power amplifier with a $0.1\mu F$ capacitance load. For load capacitances above $0.001\mu F$, the noise reduction network shown in Figure 34 is recommended. This network reduces noise significantly over the full bandwidth. Figure 34 shows that noise is reduced to less than $40\mu V_{P-P}$ from 1Hz to 1MHz using this network with a $0.01\mu F$ capacitor and a $2k\Omega$ resistor in series with a $10\mu F$ capacitor.

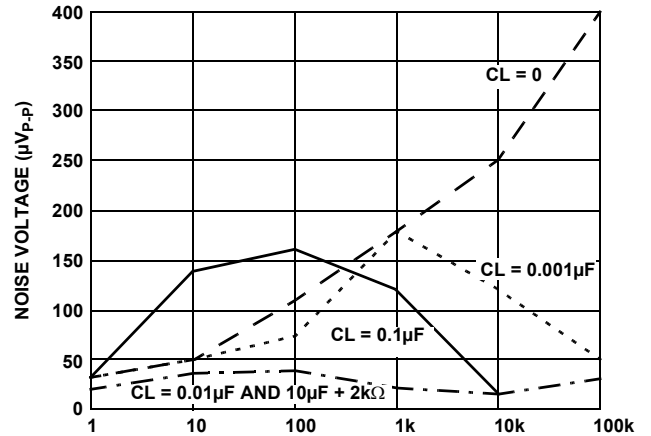

FIGURE 33. X60003 NOISE REDUCTION

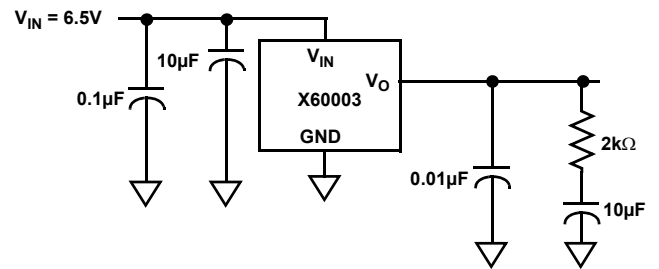

FIGURE 34. NOISE REDUCTION NETWORK

Turn-On Time

The X60003 device has ultra-low supply current and thus the time to bias-up internal circuitry to final values will be longer than with higher power references. Normal turn-on time is typically 7ms. This is shown in the graph, Figure 31. Since devices can vary in supply current down to 300nA, turn-on time can last up to about 12ms. Care should be taken in system design to include this delay before measurements or conversions are started.

Temperature Coefficient

The limits stated for temperature coefficient (tempco) are governed by the method of measurement. The overwhelming standard for specifying the temperature drift of a reference is to measure the reference voltage at two temperatures, take the total variation ($V_{HIGH} - V_{LOW}$), and divide by the temperature extremes of measurement ($T_{HIGH} - T_{LOW}$). The result is divided by the nominal reference voltage (at $T = +25^{\circ}C$) and multiplied by 10^6 to yield ppm/ $^{\circ}C$. This is the “Box” method for determining temperature coefficient.

Typical Application Circuits

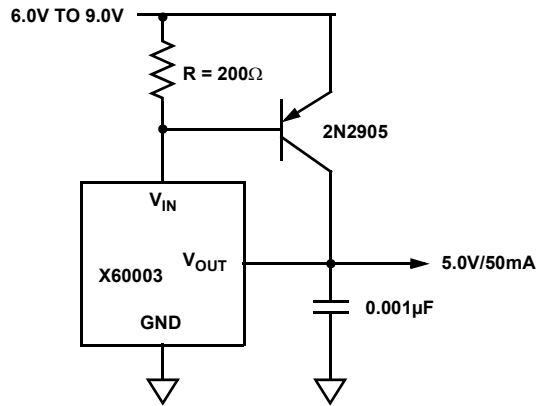

FIGURE 35. PRECISION 5V, 50mA REFERENCE

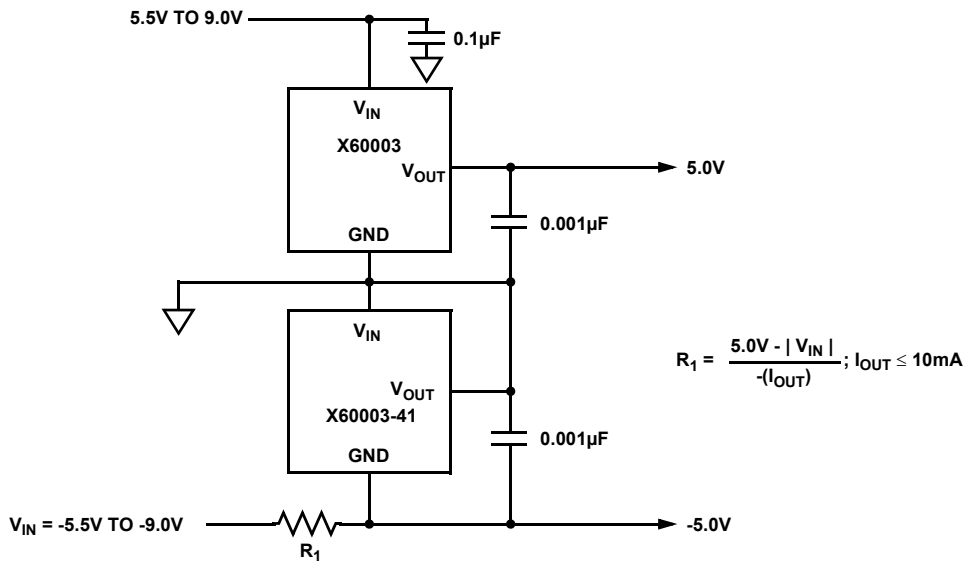

FIGURE 36. ±5.0V DUAL OUTPUT, HIGH ACCURACY REFERENCE

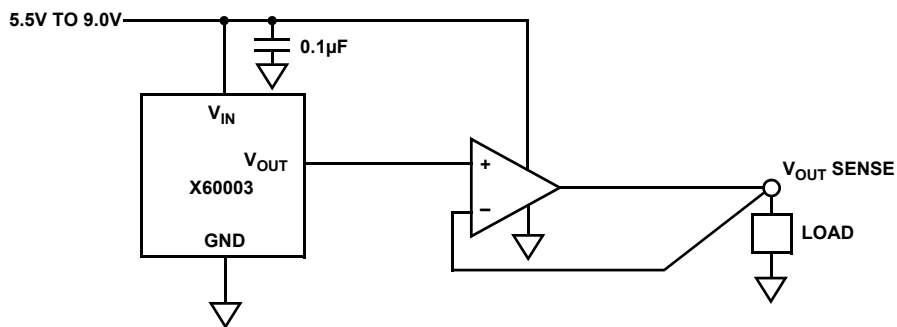
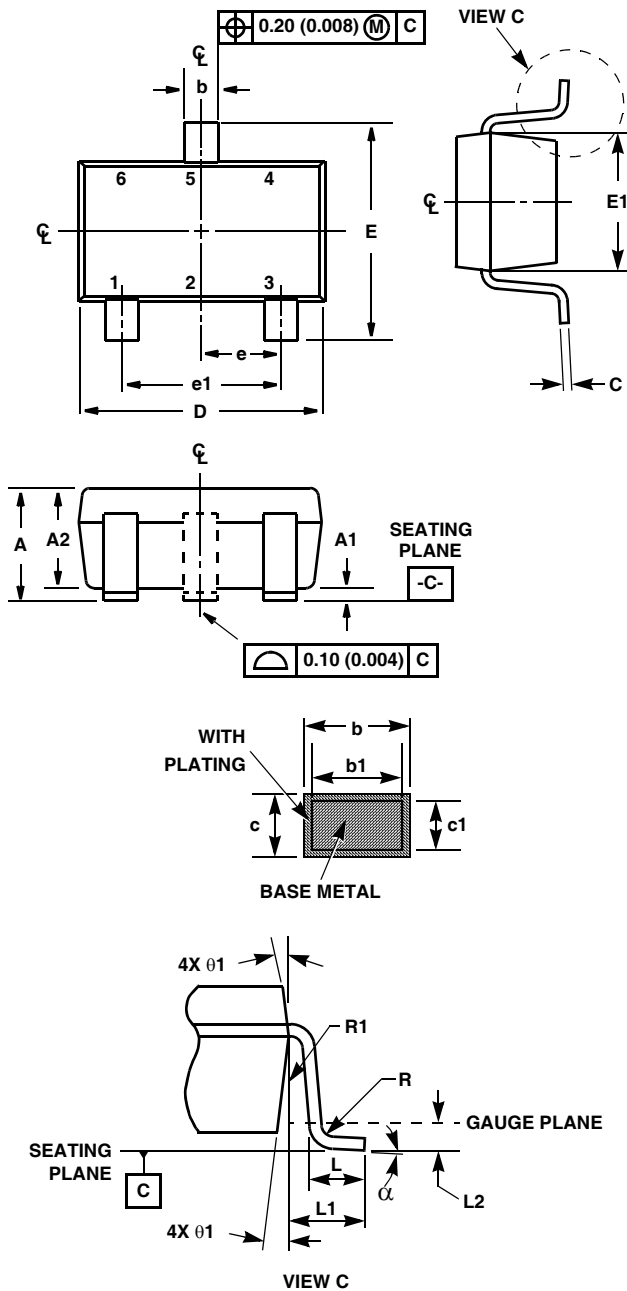

FIGURE 37. KELVIN SENSED LOAD

Small Outline Transistor Plastic Packages (SOT23-3)



P3.064

3 LEAD SMALL OUTLINE TRANSISTOR PLASTIC PACKAGE

SYMBOL	INCHES		MILLIMETERS		NOTES
	MIN	MAX	MIN	MAX	
A	0.035	0.044	0.89	1.12	-
A1	0.001	0.004	0.013	0.10	-
A2	0.035	0.037	0.88	0.94	-
b	0.015	0.020	0.37	0.50	-
b1	0.012	0.018	0.30	0.45	-
c	0.003	0.007	0.085	0.18	6
c1	0.003	0.005	0.08	0.13	6
D	0.110	0.120	2.80	3.04	3
E	0.083	0.104	2.10	2.64	-
E1	0.047	0.055	1.20	1.40	3
e	0.0374 Ref		0.95 Ref		-
e1	0.0748 Ref		1.90 Ref		-
L	-	0.016	0.21	0.41	4
L1	0.024 Ref		0.60 Ref		-
L2	0.010 Ref		0.25 Ref		-
N	3		3		5
R	0.004	-	0.10	-	-
R1	0.004	0.010	0.10	0.25	-
a	0°	8°	0°	8°	-

Rev. 1 11/06

NOTES:

1. Dimensioning and tolerance per ASME Y14.5M-1994.
2. Package conforms to EIAJ SC-74 and JEDEC MO178AB.
3. Dimensions D and E1 are exclusive of mold flash, protrusions, or gate burrs.
4. Footlength L measured at reference to gauge plane.
5. "N" is the number of terminal positions.
6. These Dimensions apply to the flat section of the lead between 0.08mm and 0.15mm from the lead tip.
7. Controlling dimension: MILLIMETER. Converted inch dimensions are for reference only
8. Die is facing up for mold die and trim-form.

All Intersil U.S. products are manufactured, assembled and tested utilizing ISO9000 quality systems. Intersil Corporation's quality certifications can be viewed at www.intersil.com/design/quality

Intersil products are sold by description only. Intersil Corporation reserves the right to make changes in circuit design, software and/or specifications at any time without notice. Accordingly, the reader is cautioned to verify that data sheets are current before placing orders. Information furnished by Intersil is believed to be accurate and reliable. However, no responsibility is assumed by Intersil or its subsidiaries for its use; nor for any infringements of patents or other rights of third parties which may result from its use. No license is granted by implication or otherwise under any patent or patent rights of Intersil or its subsidiaries.

For information regarding Intersil Corporation and its products, see www.intersil.com