

**AT91SAM9M10-G45-EK**

.....  
**User Guide**



---

## **Section 1**

Introduction .....	1-1
1.1 Scope .....	1-1
1.2 Applicable Documents .....	1-2

---

## **Section 2**

Kit Contents .....	2-1
2.1 Deliverables .....	2-1
2.2 Evaluation Board Specifications.....	2-2
2.3 Electrostatic Warning .....	2-2

---

## **Section 3**

Power up.....	3-1
3.1 Power Up the Board.....	3-1
3.2 Battery.....	3-1
3.3 DevStart .....	3-1
3.4 Recovery Procedure .....	3-2
3.5 Sample Code and Technical Support .....	3-2

---

## **Section 4**

Board Description .....	4-1
4.1 Equipment on the Board .....	4-1
4.1.1 Interfaces .....	4-1
4.1.2 Board Interface Connection .....	4-2
4.1.3 Push Button Switches.....	4-2
4.1.4 Display LCD and LEDs .....	4-3
4.2 Hardware Layout and Configuration .....	4-3
4.2.1 Processor.....	4-3
4.2.2 Clock Circuitry.....	4-4
4.2.3 Reset Circuitry .....	4-4
4.2.4 Memory .....	4-4
4.2.5 Power Supplies .....	4-7
4.2.6 Debug Interface .....	4-10
4.2.7 Audio Stereo Interface .....	4-15
4.2.8 TV-Out Extension .....	4-17
4.2.9 Software Controlled LEDs .....	4-18
4.2.10 Serial Peripheral Interface Controller (SPI) .....	4-19
4.2.11 Two Wire Interface (TWI).....	4-19
4.2.12 SD/MMC Interface .....	4-19
4.2.13 TFT LCD with Touch Panel .....	4-20
4.2.14 Push Buttons .....	4-22

---

**Section 5**

Configuration ..... 5-1

- 5.1 JTAG/ICE Configuration..... 5-1
- 5.2 ETHERNET Configuration ..... 5-1
- 5.3 Jumpers Configuration ..... 5-2
- 5.4 Miscellaneous Configuration Items ..... 5-3
- 5.5 PIO Configuration..... 5-3
  - 5.5.1 Peripheral Signals Multiplexing on I/O Lines ..... 5-3
  - 5.5.2 Multiplexing on PIO Controller A (PIOA)..... 5-3
  - 5.5.3 Multiplexing on PIO Controller B (PIOB)..... 5-5
  - 5.5.4 Multiplexing on PIO Controller C (PIOC) ..... 5-6
  - 5.5.5 Multiplexing on PIO Controller D (PIOD) ..... 5-7
  - 5.5.6 Multiplexing on PIO Controller E (PIOE)..... 5-8

---

**Section 6**

Connectors ..... 6-1

- 6.1 Power Supply ..... 6-1
- 6.2 RS232 Connector with RTS/CTS Handshake Support..... 6-1
- 6.3 DBGU..... 6-2
- 6.4 Ethernet..... 6-3
- 6.5 USB Host ..... 6-3
- 6.6 USB Host/Device ..... 6-4
- 6.7 JTAG Debugging Connector..... 6-4
- 6.8 SD/MMC- MCI0..... 6-6
- 6.9 SD/MMC- MCI1 ..... 6-7
- 6.10 AC97 ..... 6-8
- 6.11 Image Sensor - ISI ..... 6-9
- 6.12 Video ..... 6-10
- 6.13 Display Devices..... 6-10
  - 6.13.1 TFT LCD ..... 6-10
- 6.14 LCD Extension ..... 6-11

---

**Section 7**

Schematics ..... 7-1

- 7.1 Schematics..... 7-1

---

**Section 8**

Revision History ..... 8-1

- 8.1 Revision History ..... 8-1



### 1.1 Scope

This User Guide introduces the AT91SAM9M10(G45) Evaluation Kit and describes its development and debugging capabilities.

**Figure 1-1.** Board Photo



The Atmel® SAM9M10-G45-EK is a fully-featured evaluation platform for the Atmel AT91SAM9M10 or AT91SAM9G45 microcontroller. The kit is equipped with an AT91SAM9M10 chip, which is a superset of the AT91SAM9G45, and therefore allows evaluating that reference as well. The evaluation kit allows users to extensively evaluate, prototype and create application-specific designs.

The SAM9M10-G45-EK includes many hardware peripherals such as:

- Two high speed USB hosts and one high speed device port
- An Ethernet 10/100 interface
- Two high speed multimedia card interfaces

## Introduction

- An LCD TFT display (480\*272 RGB) with resistive touch panel
- A composite video output
- A camera interface
- Several communication peripherals such as:
  - Universal Synchronous/Asynchronous Receiver Transmitter (USART)
  - Two-Wire Interface (TWI)

The external memory block is made of 3 memory types:

- DDR2-SDRAM
- NAND Flash
- NOR Flash (not populated by default)

---

## 1.2 Applicable Documents

**Table 1-1.** Applicable Documents

Reference	Title	Comments
Atmel Literature n° 6438	SAM9G45 Preliminary	This document describes the SAM9G45, which is part of the Atmel's Smart ARM® Microcontrollers. It is available from <a href="http://www.atmel.com/dyn/resources/prod_documents/doc6438.pdf">http://www.atmel.com/dyn/resources/prod_documents/doc6438.pdf</a>
Atmel Literature n° 6355	SAM9M10 Preliminary	This document describes the SAM9M10, which is part of the Atmel's Smart ARM® Microcontrollers <a href="http://www.atmel.com/dyn/resources/prod_documents/doc6355.pdf">http://www.atmel.com/dyn/resources/prod_documents/doc6355.pdf</a>

### 2.1 Deliverables

The Atmel SAM9M10-G45-EK toolkit includes:

- Board
  - The SAM9M10-G45-EK board
- Power supply
  - Universal input AC/DC power supply with US, Europe and UK plug adapters
  - One 3V Lithium Battery type CR1225
- Cables
  - One micro A/B-type USB cable
  - One serial RS232 cable
  - One RJ45 crossed cable
- A Welcome Letter

**Figure 2-1.** Unpacked SAM9M10-G45-EK



Unpack and inspect this kit carefully. Contact your local Atmel distributor, should you have issues concerning the contents of the kit.

---

## 2.2 Evaluation Board Specifications

**Table 2-1.** SAM9M10-G45-EK Specifications

Characteristics	Specifications
Clock speed	400 MHz PCK, 133 MHz MCK
Ports	Ethernet, USB, RS232, DBGU, JTAG
Board supply voltage	5 VDC from connector
Temperature - operating - storage	-10° to +50° C -40° to +85° C
Relative humidity	0 to 90% (non condensing)
Dimensions	180 mm x 140 mm
RoHS status	Compliant

---

## 2.3 Electrostatic Warning

The SAM9M10-G45-EK evaluation board is shipped in a protective anti-static package. The board must not be subjected to high electrostatic potentials. We strongly recommend using a grounding strap or similar ESD protective device when handling the board in hostile ESD environments (offices with synthetic carpet, for example...). Avoid touching the component pins or any other metallic element on the board.



#### 3.1 Power Up the Board

Unpack the board taking care to avoid electrostatic discharge. Unpack the power supply, select the right power plug adapter corresponding to that of your country, and insert it in the power supply.

Connect the power supply DC connector to the board and plug the power supply to an AC power plug.

The board LCD should light up and display a welcome page. Then, click or touch icons displayed on the screen and enjoy the demo.

---

#### 3.2 Battery

The SAM9M10-G45-EK ships with a 3V coin battery.

This battery is not required for the board to start up.

The coin battery is provided for user convenience in case the user would like to exercise the date and time backup function of the SAM9M10 series devices when the board is switched off.

---

#### 3.3 DevStart

The on-board NAND Flash contains a “SAM9M10-G45-EK DevStart”.

It is stored in the “SAM9M10-G45-EK DevStart” folder on the USB Flash disk available when the SAM9M10-G45-EK is connected to a host computer.

Click the file “welcome.html” in this folder to launch SAM9M10-G45-EK DevStart.

SAM9M10-G45-EK DevStart guides you through installation processes of IAR™ EWARM, Keil MDK and GNU toolkits. Then, it gives you step-by-step instructions on how to rebuild a single example project and how to program it into the SAM9M10-G45-EK. Optionally, if you have a SAM-ICE™, instructions are also given about how to debug the code.

**We recommend that you backup the “SAM9M10-G45-EK DevStart” folder on your computer before launching it.**



---

### 3.4 Recovery Procedure

The DevStart ends by giving step-by-step instructions on how to recover the SAM9M10-G45-EK to the state as it was when shipped by Atmel.

Follow the instructions if you deleted the contents of the NAND Flash and want to recover from this situation.

---

### 3.5 Sample Code and Technical Support

After boot up, you can run some sample code or your own application on the development kit. You can download sample code and get Technical support from [http://www.atmel.com/dyn/products/tech\\_support.asp?Faq=y&family\\_id=689%20](http://www.atmel.com/dyn/products/tech_support.asp?Faq=y&family_id=689%20).

### 4.1 Equipment on the Board

Figure 4-1. Board Architecture

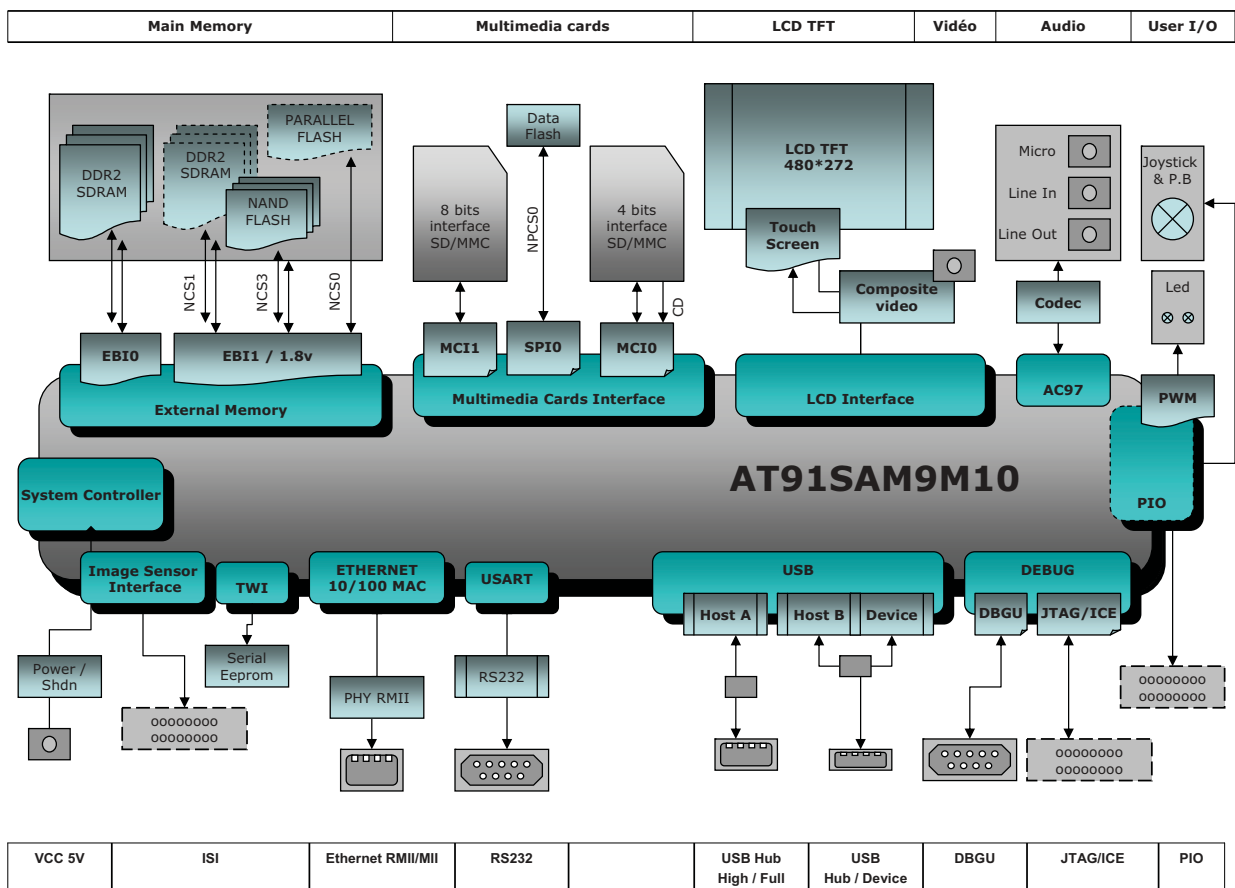

#### 4.1.1 Interfaces

The board is equipped with an AT91SAM9M10-CU embedded microprocessor (324-ball TFBGA package) together with the following interfaces or peripherals:

- DDR2/LPDDR memory interface is connected to 128 MB DDR2-SDRAM memory
- External Bus Interface (EBI) is connected to three kinds of memory devices (DDR2-SDRAM, NAND Flash and NOR Flash (not populated))

## Board Description

- One TWI serial memory
- One USB Host/Device multiplexed port interface
- One USB Host port interface
- One RS232 serial communication port
- One DBGU serial communication port
- One JTAG/ICE debug interface
- One Ethernet 100-base TX with three status LEDs
- One AC97 Audio CODEC with headphone line out, line in and mono/stereo microphone inputs
- One TV interface (composite video output)
- One 4.3" TFT LCD Module with touch screen and back light
- One ISI connector (camera interface)
- One power red LED and two general-purpose green LEDs
- Two user input push buttons
- One joystick with 4-direction control and selector
- One wakeup input push button
- One reset input push button
- One SD/SDIO/MMC plus card slot (4/8 bit interface)
- One SD/SDIO/MMC card slot (4-bit interface)
- One Lithium Coin Cell Battery Retainer for 12 mm cell size (memory backup usage)

### 4.1.2 Board Interface Connection

- Ethernet using RJ45 connector (J15)
- USB Host, support USB host using a type A connector (J12)
- USB Host/Device, support USB host/device using a type micro AB connector (J14)
- UART1 (RX, TX, RTS, CTS) connected to a 9-way male D-type RS232 connector (J11)
- DBGU (RX and TX only) connected to a 9-way male D-type RS232 connector (J10)
- JTAG, 20 pin IDC connector (J13)
- SD/MMCplus connector (J5)
- SD/MMC connector (J6)
- Headphone (J7), line-in (J8) and microphone headset (J9)
- Speaker output (JP15)
- Image sensor connector (J17)
- TFT LCD display, with TouchScreen and backlighth (J24)
- Test points; various test points are located throughout the board
- Main power supply (J2)

### 4.1.3 Push Button Switches

- Reset, board reset (BP1)
- Wake up, push button to bring processor out of low power mode (BP2)
- Right and left click, user push button switches (BP4 and BP5)
- Joystick (BP3)



#### 4.1.4 Display LCD and LEDs

- Display, 480xRGBx272 pixels LCD module display connected to the PIO port E (LCD1)
- One surface-mounted power red LED, user interface (D3)
- Two surface-mounted green LEDs, user interface (D1 and D2)
- Three surface-mounted LEDs indicate Ethernet status (D4, D5, D6)

Figure 4-2. Board Layout Commented

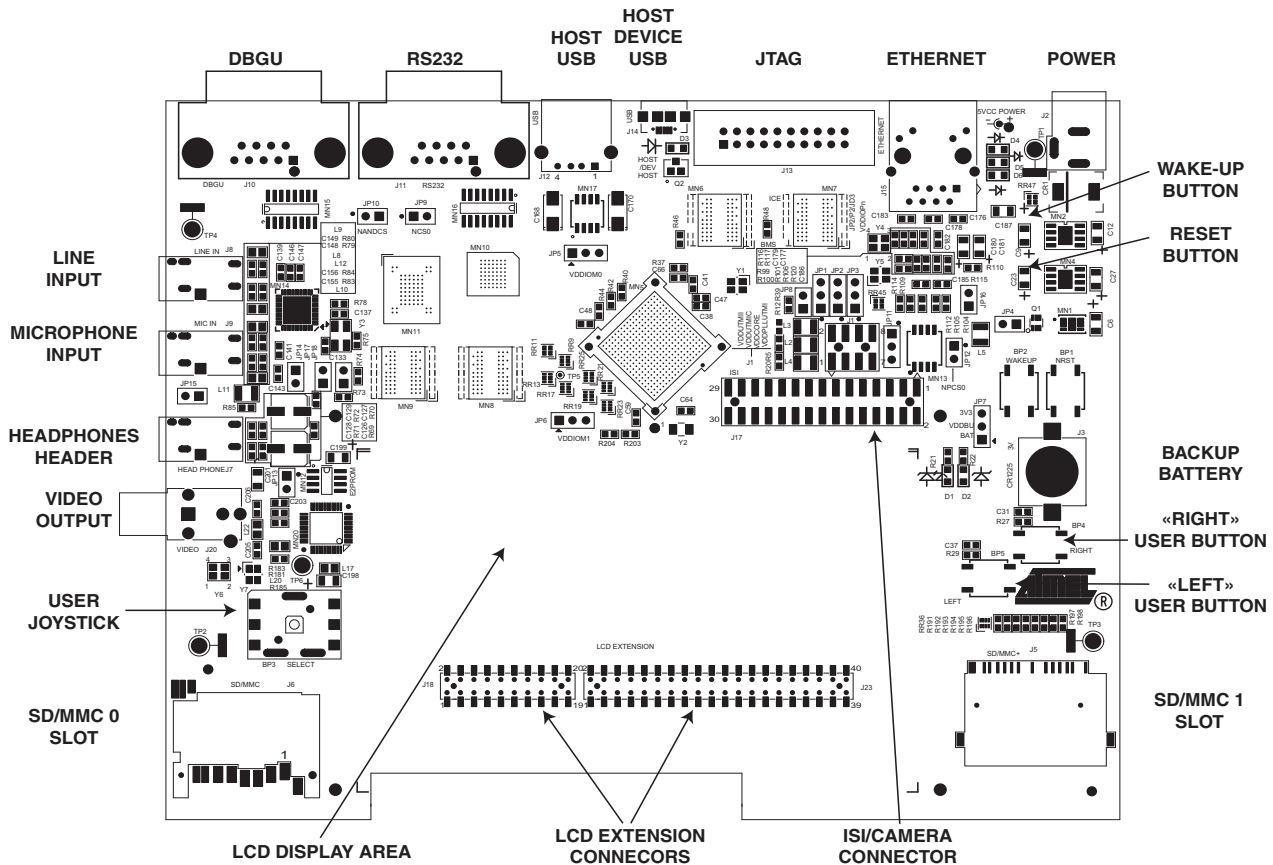

The major components of the SAM9M10-G45-EK board are shown in Figure 4-1.

## 4.2 Hardware Layout and Configuration

### 4.2.1 Processor

The board features the Atmel SAM9M10-CU 324-ball TFBGA package. This chip runs at a nominal frequency of 400 MHz for the core and 133 MHz for the system bus.

For more information, refer to the latest SAM9M10 datasheet available from <http://www.atmel.com/>

## Board Description

### 4.2.2 Clock Circuitry

The SAM9M10-G45-EK includes six clock sources:

- Two are alternatives for the SAM9M10 main clock,
- One crystal and one crystal oscillator are used for the Ethernet MII/RMII chip,
- One crystal is used for the AC97 codec chip,
- One crystal or one crystal oscillator is used for the TV encoder.

**Table 4-1.** Main Components Associated with the Clock Systems

Quantity	Description	Component assignment
1	Crystal for Internal Clock, 12 MHz	Y1
1	Crystal for RTC Clock, 32.768 kHz	Y2
1	Oscillator for Ethernet Clock RMII, 50 MHz	Y4
1	Crystal for Ethernet Clock MII, 25 MHz (not populated)	Y5
1	Crystal for AC97 Codec Clock, 24.576 MHz	Y3
1	Crystal for TV Encoder Clock, 13 MHz, or Oscillator for TV Encoder, 13 MHz (not populated)	Y7 Y6

### 4.2.3 Reset Circuitry

The reset sources are:

- Power on reset
- Push button reset
- JTAG reset from an in-circuit emulator interface.

### 4.2.4 Memory

#### 4.2.4.1 External Memories

The SAM9M10 features a DDR2/LPDDR memory interface and an External Bus Interface (EBI) to permit interfacing to a wide range of external memories and to almost any kind of parallel peripheral.

The SAM9M10-G45-EK board is equipped with DDR2/LPDDR devices featuring 128 MB of DDR2-SDRAM memory (16Meg\*8\*4).

The External Bus Interface (EBI) is connected to three kinds of memory devices:

- One Parallel Flash (not populated by default)
- Two DDR2-SDRAM
- One NAND Flash (2Gb, 8 bit bus)

The chip selects NCS0, NCS1 and NCS3 are used for NOR Flash, DDR2-SDRAM and NAND Flash memories, respectively. Furthermore, a dedicated jumper can disconnect each of the two NCS0 and NCS3 signals, making them available for other functions.

Figure 4-3. EB10 - DDR2

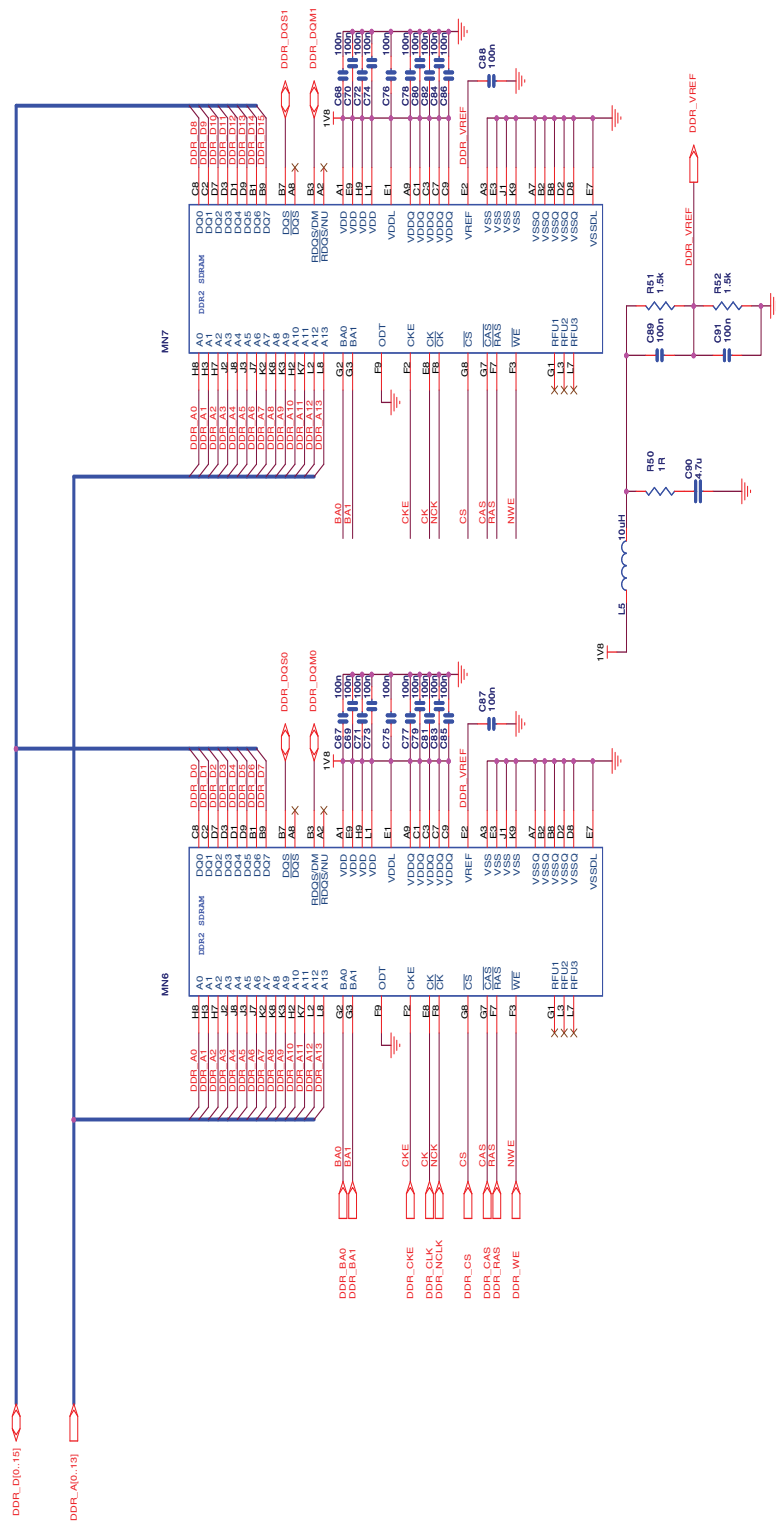



## 4.2.5 Power Supplies

The SAM9M10 Board contains four regulated power supplies:

- 3.3 VDC Supply
- 1.8 VDC Supply
- 1.0 VDC Core Supply
- 1.0 VDC Core UTMI Supply, PLL

The outputs of these regulated power supplies<sup>1</sup> are distributed as necessary to each part of the circuit board.

- The 3.3 VDC Supply is generated by an adjustable LDO. It accepts VIN 5 VCC power and outputs a regulated +3.3 V to most other circuits on the board.
- The 1.8 VDC Supply (VDDIOM0, VDDIOM1) is generated by an adjustable LDO. It is powered by VIN 5 VCC power and outputs a regulated +1.8V.
- The 1.0 VDC Core Supply (VDDCORE) is generated by an adjustable LDO. It is powered by the output of the 3.3 VDC Supply.
- The 1.0 VDC Core Supply (VDDUTMIC, VDDPLLUTMI and VDDPLLA) is generated by an adjustable LDO RT9186A series. It is powered by the output of the 3.3 VDC Supply.

**Note:** 1. Corresponding test points (TP1 to TP4, GND) are used with jumpers (JP1.1 to JP7) to permit probing of these voltages.



Figure 4-5. Power Supply

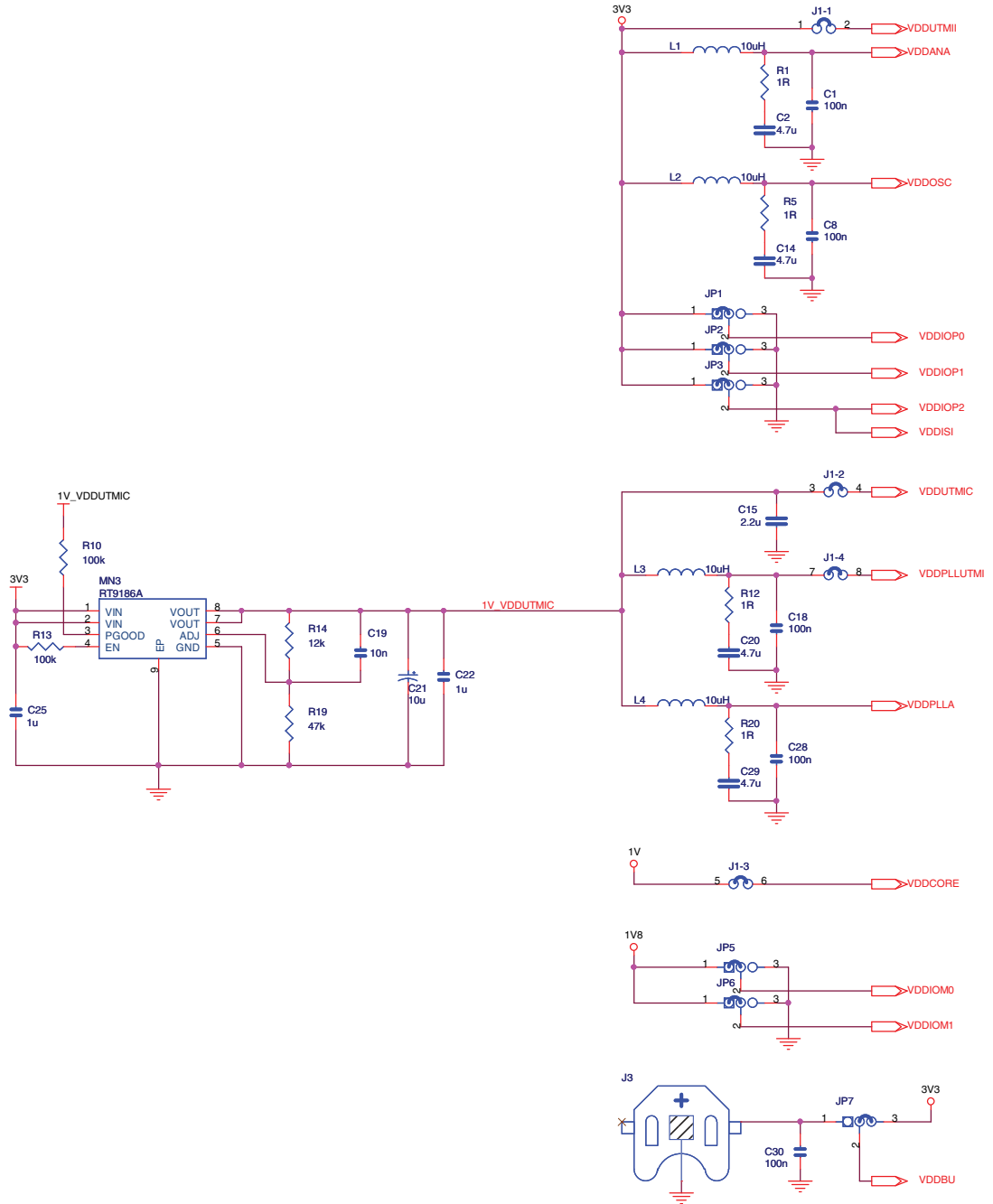
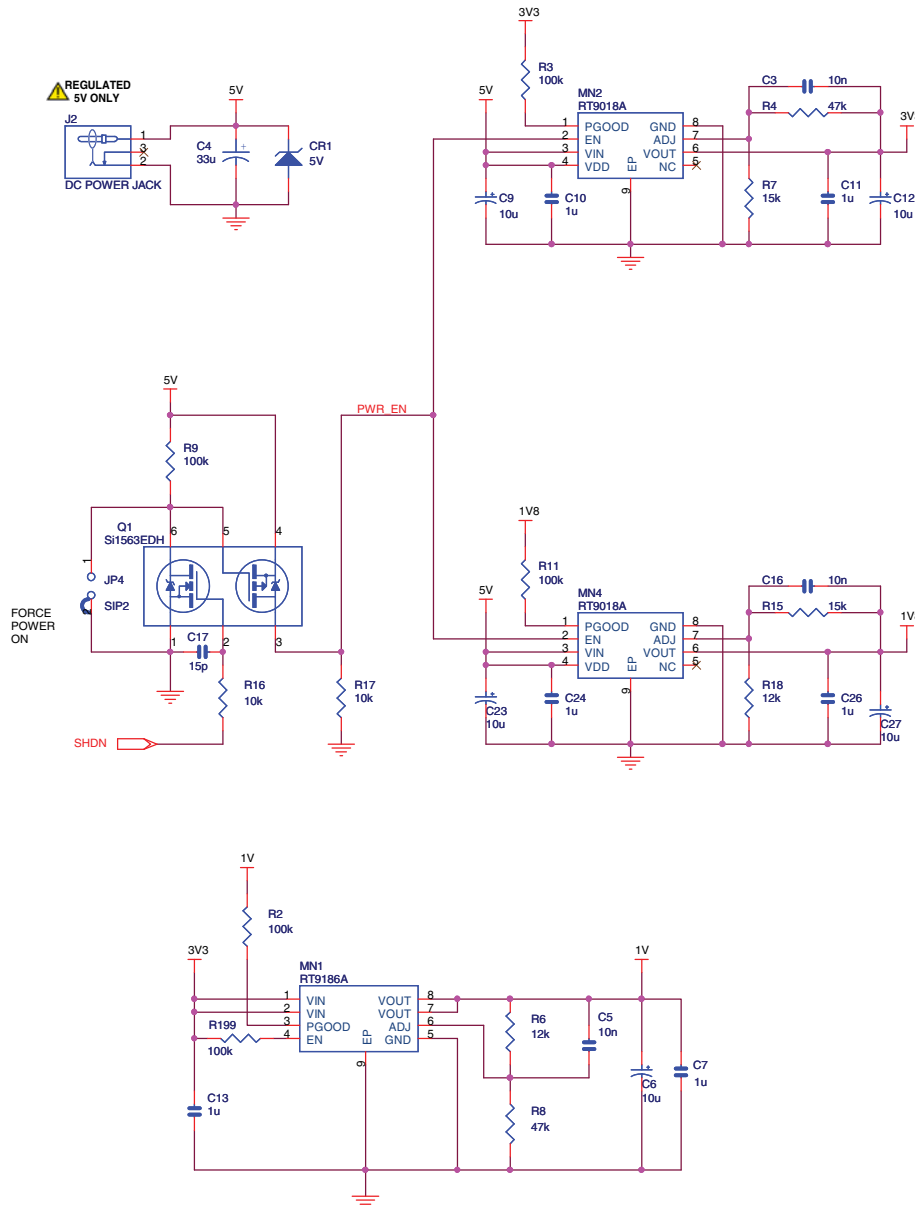

Figure 4-6. Management Power Block



## Board Description

### 4.2.6 Debug Interface

#### 4.2.6.1 JTAG/ICE

Software debug is accessed by a standard 20-pin JTAG connection. This allows connection to a standard USB-to-JTAG in-circuit emulator.

**Figure 4-7.** JTAG Interface

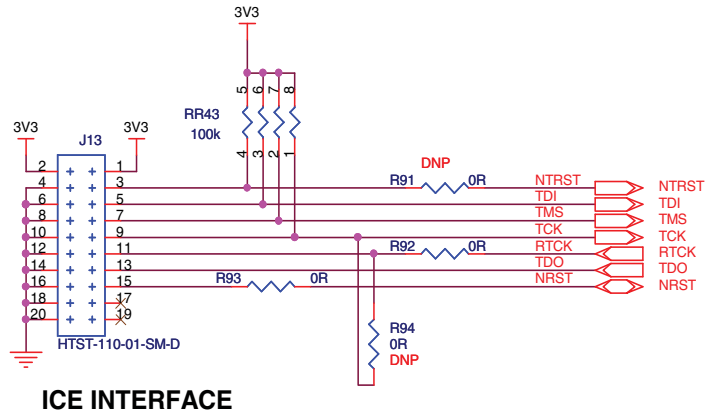

#### 4.2.6.2 DBGU Com Port

This UART is connected to the DB-9 male socket through an RS-232 Transceiver (TXD and RXD only).

**Figure 4-8.** DBGU Com Port

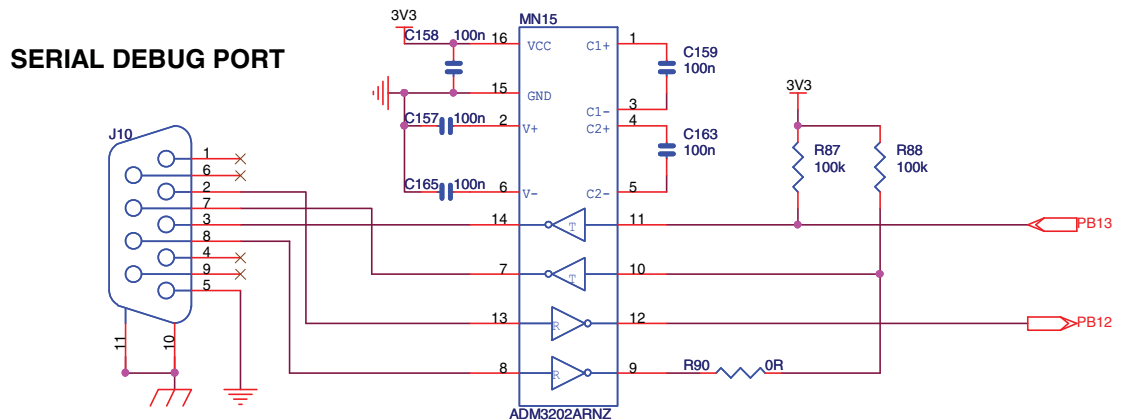

### 4.2.6.3 User Serial Com Port

The USART1 is used as a user serial communication port. This USART1 is buffered with an RS-232 Transceiver (TXD, RXD and handshake CTS/RTS control) and connected to the DB-9 male socket. Software must assign the appropriate PIO pins (PB5 = RXD1, PB4 = TXD1, PD16 = RTS1, PD17 = CTS1) to enable the UART1 function.

**Figure 4-9.** User Serial Com Port

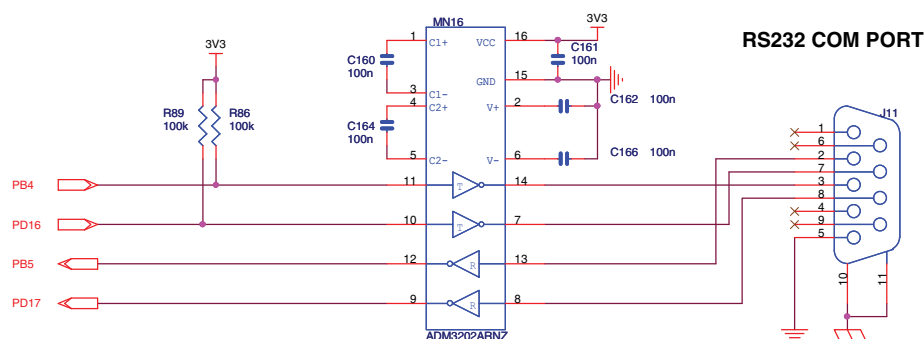

Refer to the SAM9M10 datasheet for more information about the SAM9M10 USARTs.

### 4.2.6.4 USB Port

The SAM9M10-G45-EK features USB communication ports:

- Two Host Ports: Full speed OHCI and High speed EHCI
- One Device Port: High speed.

USB Host Port0 is directly connected to the first UTMI transceiver. The second Host Port (Port1) is multiplexed with the USB Device High speed and connected to the second UTMI port.

- One USB high/full speed type standard A connector
- One USB interface Host/Device Micro AB connector

Refer to the SAM9M10 datasheet for detailed programming information.

Figure 4-10. USB Port

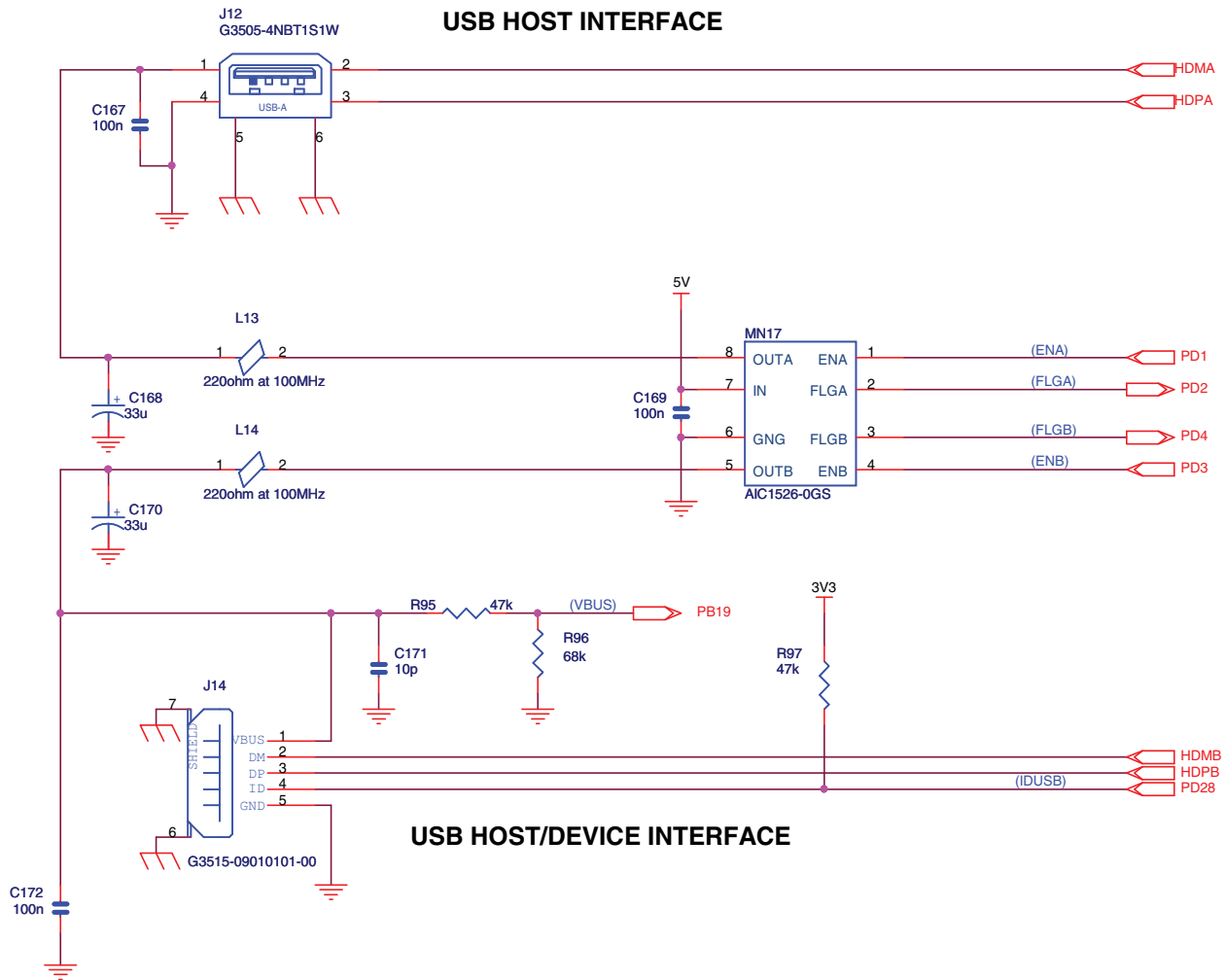

#### 4.2.6.5 Ethernet 10/100 (EMAC) Port

The port is compatible with IEEE® Standard 802.3.

The SAM9M10-G45-EK is equipped with a Davicom DM9161AEP 10/100 Mbps Fast Ethernet Physical Layer TX/FX Single Chip Transceiver. It contains the entire physical layer functions of 100BASE-TX as defined by IEEE 802.3u, including the Physical Coding Sublayer (PCS), Physical Medium attachment (PMA), Twisted Pair Physical Medium Dependent Sublayer (TP-PMD), 10BASE-TX Encoder/Decoder (ENC/DEC), and Twisted Pair Media Access Unit (TPMAU).

The Ethernet interface integrates an RJ45 connector with an embedded transformer, and three status LEDs.

The Ethernet interface provides two selectable modes, MII or RMII (Reduced MII), for 100Base-TX or 10Base-TX. The MII and RMII interfaces are capable of both 10Mb/s and 100Mb/s data rates as described in the IEEE 802.3u standard. The signals used by MII and RMII interfaces are described in the table below.

**Table 4-2.** Pin Mapping for Normal MII and Reduced MII

Pin Name	Normal MII Mode		Reduced MII Mode	
	SAM9M10	DM9161	SAM9M10	DM9161
ETX0-ETX1	ETX[0:1] transmit data	TXD [0:1]	ETX[0:1]	TXD [0:1]
ETX2-ETX3	ETX[2:3] transmit data	TXD [2:3]	NC	NC
ETXEN	ETXEN: transmit enable	TXEN	ETXEN: transmit enable	TXEN
ETXER	ETXER: transmit error	TXER/TXD[4]	NC	NC
ETXCK/REFCK	ETXCK: transmit clock	TXCLK	REFCK: reference clock	REF_CLK
ERX0-ERX1	ERX[0:1]: receive data	RXD [0:1]	ERX[0:1]: receive data	RXD [0:1]
ERX2-ERX3	ERX[2:3]: receive data	RXD [2:3]	NC	NC
ERXER	ERXER: receive error	RXER/RXD[4]/ RPTR/NODE	ERXER: receive error	RPTR/NODE
ERXDV	ERXDV: receive valid data	RXDV	ECRSDV: carrier sense / data valid	CRS DV
ERXCK	ERXCK: receive clock	RXCLK	NC	NC
ECOL	ECOL: collision detect	COL	NC	NC
ECRS	ECRS: carrier sense / data valid	CRS (PHYAD[2:4])	NC	NC
EMDC	EMDC: management data clock	MDC	EMDC: management data clock	MDC
EMDIO	EMDIO: management data input / output	MDIO	EMDIO: management data input / output	MDIO
NRST	NRST: microcontroller reset	RESET# XT1 (25 MHz)	NRST: microcontroller reset	RESET# XT1 (REF_CLK 50MHz)

Figure 4-11. Ethernet Port

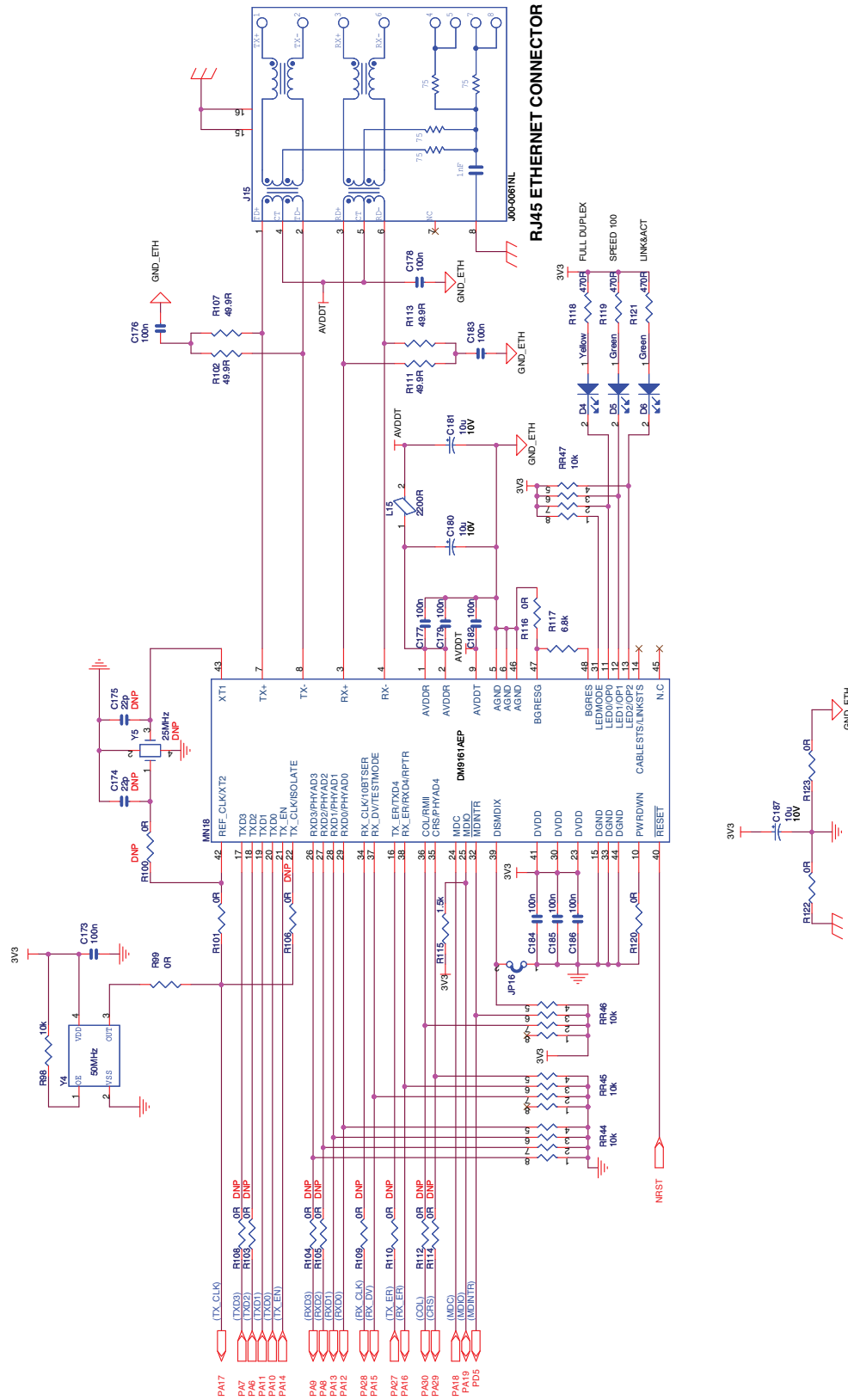

For more information about the Ethernet controller device, refer to the Davicom DM9161 controller manufacturer's datasheet.



**4.2.7 Audio Stereo Interface**

The SAM9M10-G45-EK includes a WM9711L AC97 CODEC for digital sound input and output. This interface includes audio jacks for MIC input (J9), line audio input (J8), headphone line output (J7) and a 2-point speaker output connector (JP15).

It is compliant with AC97 Component Specification V2.2.



Figure 4-12. Audio Stereo Interface

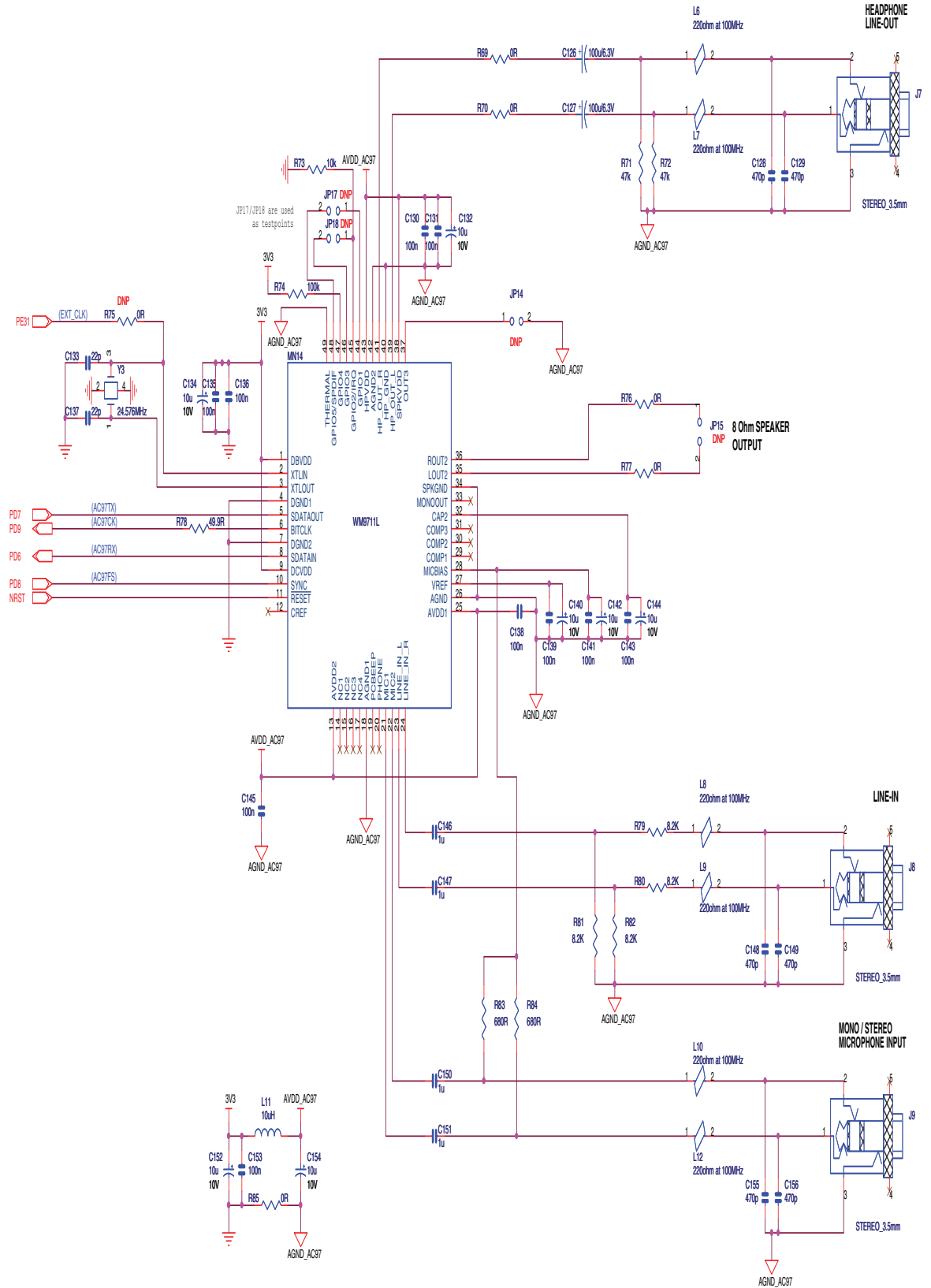

For more information about the AC97 codec device, refer to the Wolfson WM9711L controller manufacturer's datasheet.



### 4.2.8 TV-Out Extension

The Chronitel™ CH7024 chip provides an interface between the SAM9M10 LCD Controller and a TV set by converting LCD signals to TV signals.

The CH7024 is a TV encoder device which encodes the video signals and generates synchronization signals for NTSC and PAL standards. Supported TV output formats are NTSC-M, NTSC-J, NTSC-433, PAL-B/D/G/A/I, PAL-M, PAL-N and PAL-60. The CH7024 provides video output support for CVBS or S-video.

Figure 4-13. TV-Out Extension Port

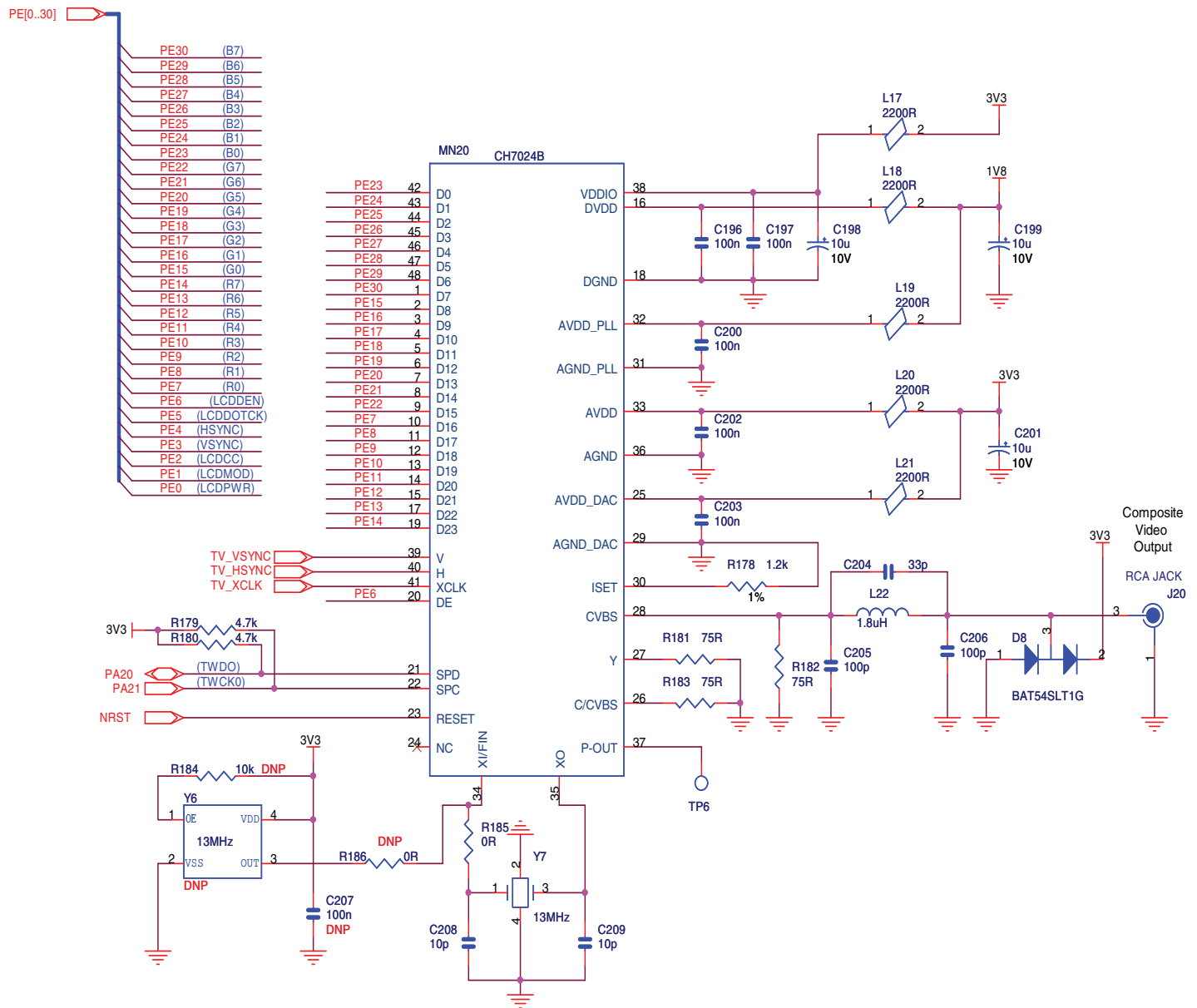

4.2.9 Software Controlled LEDs

Three users LED are provided for general use. The LEDs are connected to PIO port lines, allowing their control through either GPIO or PWM control.

- LEDs D1 to D3 are software controlled by PIO pins.
- LEDs D4 to D6 indicate Ethernet traffic and link status. These are automatically managed by on-chip microcontroller hardware. See [Section 7.1 "Schematics"](#) .

**Table 4-3.** Discrete LEDs

LED	Description	Comment
D1	Green LED	User software controlled
D2	Green LED	User software controlled
D3	Red LED	User software controlled
D4	Yellow LED	Indicates transmission or reception via Ethernet
D5	Green LED	Indicates speed 100
D6	Green LED	Is lit when a good link test has been detected

**Figure 4-14.** Software Controlled LEDs

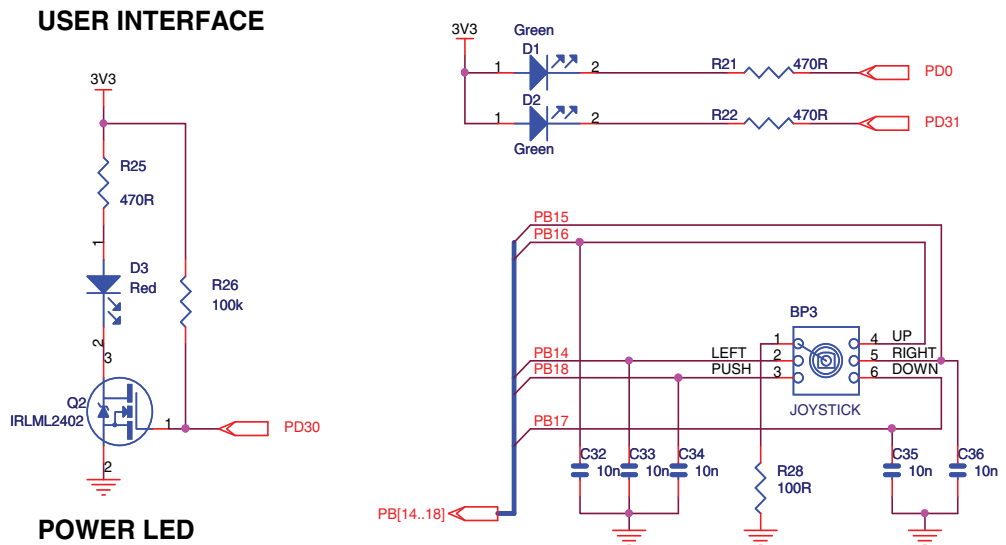

#### 4.2.10 Serial Peripheral Interface Controller (SPI)

The SAM9M10 provides two high-speed Serial Peripheral Interface (SPI) controllers. One port is used to interface with the on-board serial DataFlash®.

**Figure 4-15.** SPI

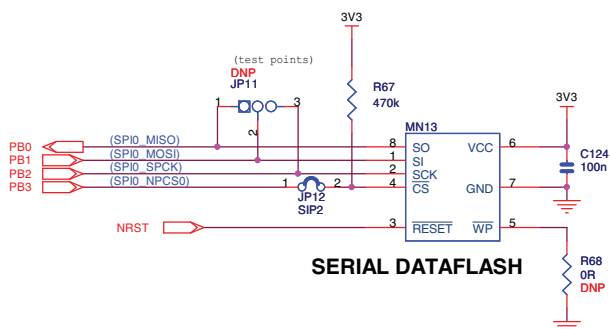

#### 4.2.11 Two Wire Interface (TWI)

The SAM9M10 has a full speed (400 kHz) master/slave I2C Serial Controller. The controller is fully compatible with the industry standard I2C and SMBus Interfaces. This port is used to interface with the on-board Serial EEPROM, ISI and TV encoder interface.

**Figure 4-16.** TWI

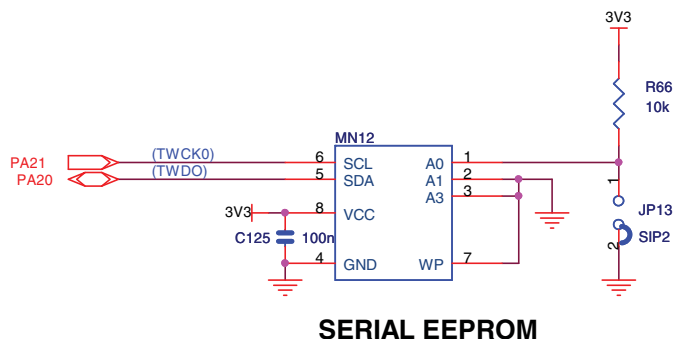

#### 4.2.12 SD/MMC Interface

The SAM9M10-G45-EK has two high-speed 8-bit multimedia interfaces MMC/MMCPlus v4.1. The first interface is used as an 8-bit interface (MCI1), connected to a CE-ATA connector footprint and an 8-bit SD/MMC card slot. The second interface is used as a 4-bit interface (MCI0), connected to a 4-bit SD/MMC card slot.

The users must provide their own compatible cards for use with these connectors.

Please note that the power is connected to VCC, which is 3.3 volts.

## Board Description

Figure 4-17. SD/MMC0

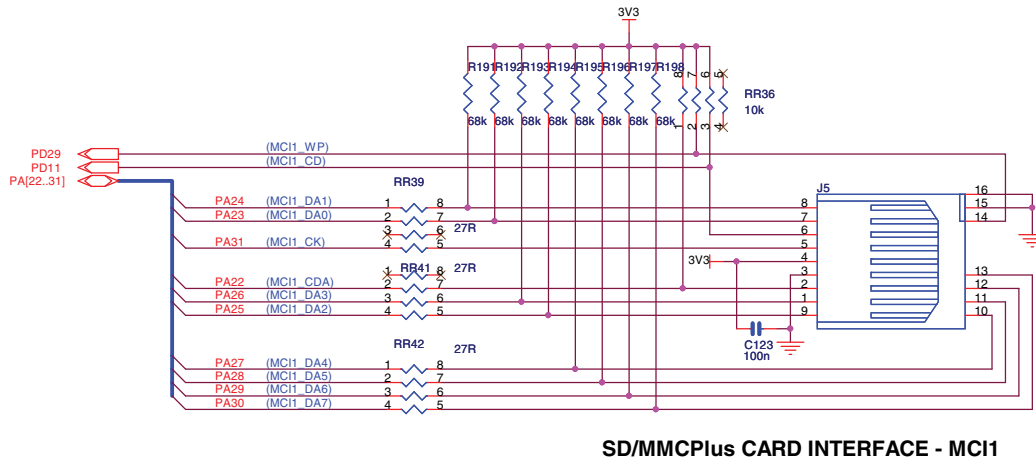
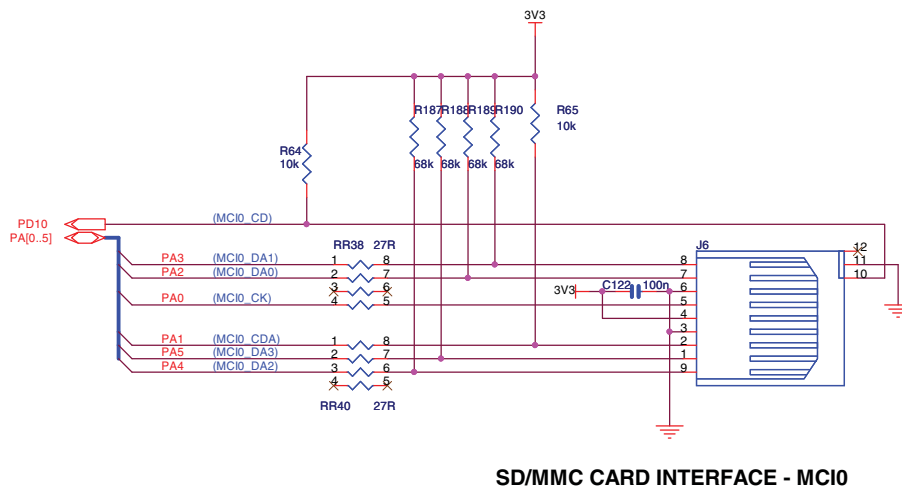

Figure 4-18. SD/MMC1



### 4.2.13 TFT LCD with Touch Panel

The SAM9M10 features an LCD controller. A 4.3" 480x272 Portrait Mode LCD provides the SAM9M10-G45-EK with a low power LCD display, back light unit and a touch panel, similar to that used on commercial PDAs.

The TFT LCD component is a truly model number TFT1N4633.

Graphics and text can be displayed on the dot matrix panel with up to 16 million colors by supplying 24-bit data signals (8bitxRGB by default) or 16-bit data signals (5+6+5bitxRGB in option). This allows the user to develop graphical user interfaces for a wide variety of end applications.

Warning: never connect/disconnect the LCD display from the board while the power supply is on. Doing so may damage both units and is not covered by warranty.

The back light voltage is generated from a CP2122ST boost converter. It is powered directly by the VIN 5 VCC power (the control for the back light voltages is separated from the main board voltages due to the specific voltage requirements of the LCD panel).

Figure 4-19. TFT LCD

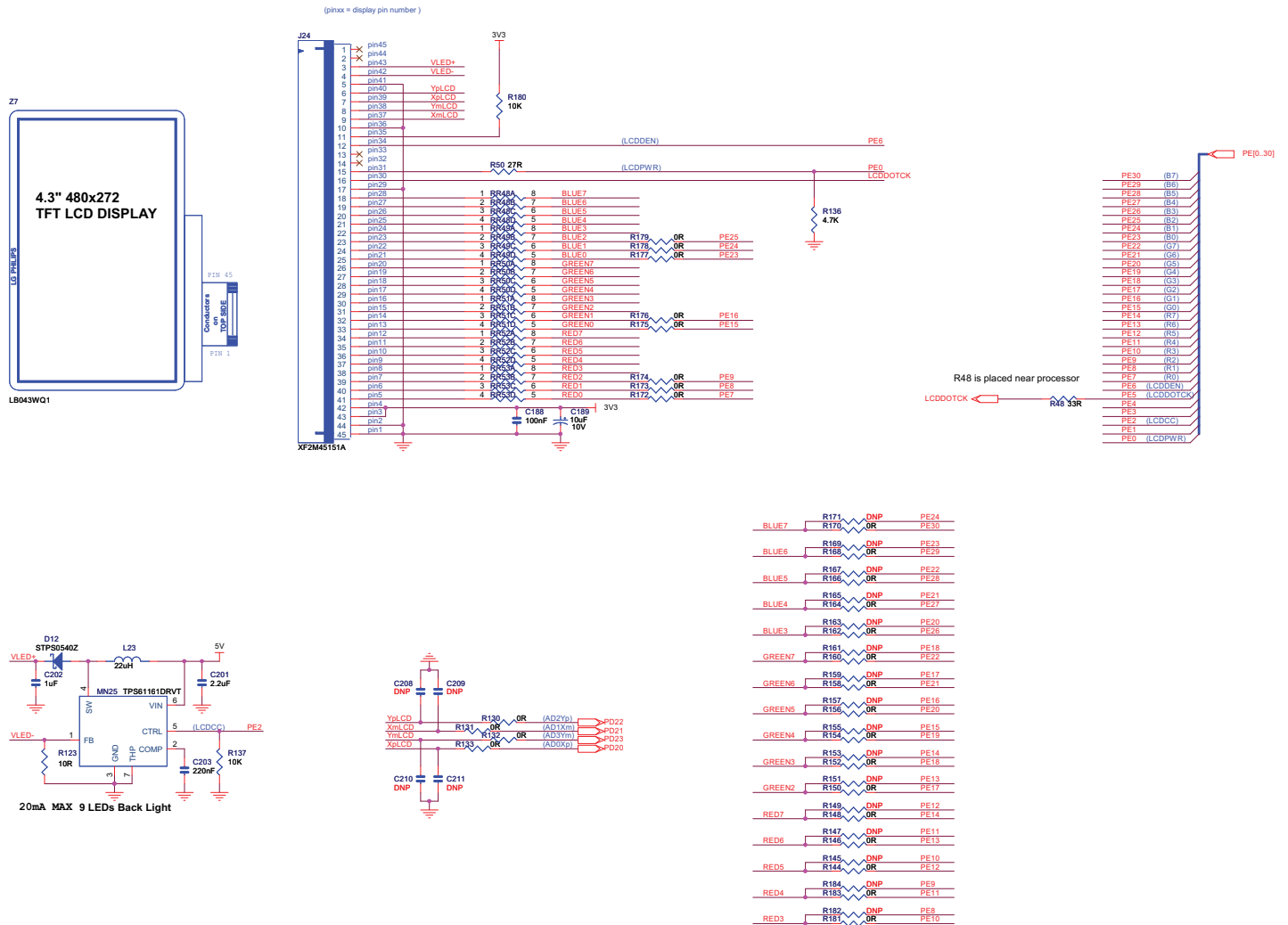

## Board Description

### 4.2.14 Push Buttons

The SAM9M10-G45-EK is equipped with two system push buttons, two user push buttons and one joystick. The push buttons consist of momentary push button switches mounted directly to the board. When any switch is depressed, a low (zero) appears at the associated input pin.

- System push buttons:
  - Reset, perform system reset
  - Wakeup, perform system wake up
- User push button:
  - Right click
  - Left click
- Joystick:
  - One touch, 5-way switching,
  - Normally open momentary contacts,
  - Push down to select in any position.

**Figure 4-20.** Push Buttons

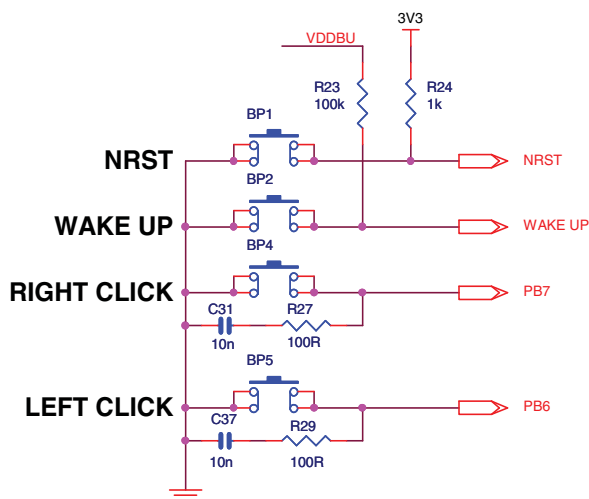

### 4.2.15 Expansion Slot

- GPIO1 & GPIO2, LCD signals (PIO E) are routed to the connectors extension J23
- All I/Os of the SAM9M10 Image Sensor Interface are routed to connectors J17
- Touch screen signals and analog I/O are connected to J18

This allows the developer to extend the features of the board by adding external hardware components or boards.

Figure 4-21. Expansion Slot

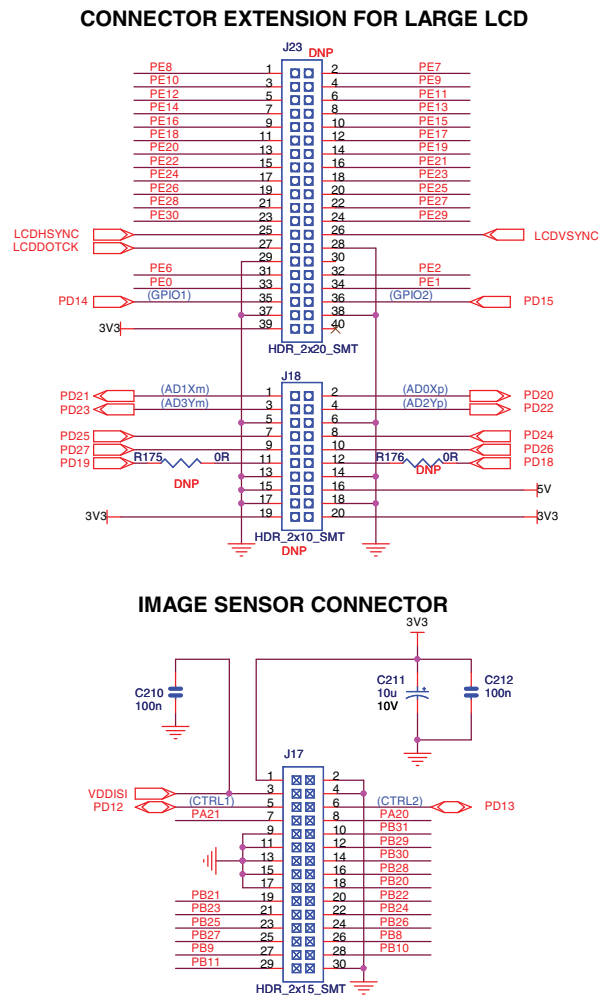





## Section 5

---

# Configuration

---

### 5.1 JTAG/ICE Configuration

*Table 5-1.* JTAG/ICE Configuration

Designation	Default Setting	Feature
R91	Not populated	Disables the ICE NTRST input
R92	Soldered	Enables the ICE RTCK return. R94 must be opened
R93	Soldered	Enables the ICE NRST input
R94	Not populated	Disables TCK <-> RTCK local loop

### 5.2 ETHERNET Configuration

RMII is the factory default mode.

To evaluate the MII mode, the user has to unsolder R99 and solder R100, R103 to R105, R108 to R110, R112, R114, C174, C175, Y5.

## 5.3 Jumpers Configuration

Two types of jumpers are used on the SAM9M10-G45-EK board:

- 2-pin jumpers with two possible settings:
  - Fitted: the circuit is closed
  - Not fitted: the circuit is open
- 3-pin jumpers with two possible positions, for which settings are presented in the following tables.

**Table 5-2.** Jumpers Configuration

Designation	Default Setting	Feature			
J1 (combined jumper array)	Closed	J1-1	1-2	VDDUTMII	3V3
	Closed	J1-2	3-4	VDDUTIMC	1V
	Closed	J1-3	5-6	VDDCORE	1V
	Closed	J1-4	7-8	VDDPLLUTMI	1V
JP1	1-2	JP1	1-2	VDDIOP0	3V3
			2-3	External power to VDDIOP0	3V3 nominal
JP2	1-2	JP2	1-2	VDDIOP1	3V3
			2-3	External power to VDDIOP1	3V3 nominal
JP3	1-2	JP3	1-2	VDDIOP2	3V3
			2-3	External power to VDDIOP2	3V3 nominal
JP4	Opened	Forces power on. To use the software shutdown control, JP4 must be opened. 3V battery backup must be present and JP7 jumper set in position 1-2			
JP5	1-2	JP5	1-2	VDDIOM0	1V8
			2-3	External power to VDDIOM0	1V8 nominal
JP6	1-2	JP6	1-2	VDDIOM1	1V8
			2-3	External power to VDDIOM1	1V8 nominal
JP7	1-2	JP7	1-2	VDDBU	Lithium 3V Battery
			2-3	VDDBU	3.3V from regulator
JP8	Opened	BMS Enables Boot on the internal ROM; closed selects the boot from the external device connected to NCS0			
JP9	Closed	Enables chip select access, Boot on the NCS0 (MN10 Flash)			
JP10	Closed	Enables chip select access, Boot on the NCS3 (MN11 NAND Flash)			
JP11	Test point	JP11.1: SO	JP11.2: SI	JP11.3: SCK	
JP12	Closed	Enables chip select access, Boot on the SPIO_NPCS0 (Serial DataFlash MN13)			
JP13	Opened	Set address A0 low (MN12 Serial EEPROM), enable Boot access.			
JP14		JP14.1 = Line_Out	JP14.3 = AGND		
JP15		Used to connect a Loudspeaker			
JP16	Closed	DISMDIX (MN18)			
JP17-JP18	Test points	Give access to the four GPIOs of WM9711L			

## 5.4 Miscellaneous Configuration Items

N.P = not populated

P = populated

**Table 5-3.** Miscellaneous Configuration

Designation	Default Setting	Feature
R34	N.P	JTAGSEL
R35	P	Connect TSADVREF to VDDANA (may be used for specific filtering)
R36	P	Connect GNDANA to GND (may be used for specific filtering)
R38	P	Force TST pin to GND (chip is set in non-test mode = normal operation mode)
R63	N.P	Write protect NAND Flash (mount a 0-ohm resistor to write-protect the NAND Flash device)
R68	N.P	Write protect serial DataFlash (mount a 0-ohm resistor to write-protect the serial Flash device)
R75	N.P	External clock Audio AC97 (mount a 0-ohm resistor to connect it)
R91,R92 R93,R94		ICE interface reset and clocking schemes (see <a href="#">Section 5.1 "JTAG/ICE Configuration"</a> )
R100, R103 to R105, R108 to R110, R112, R114, C174, C175, Y5		Ethernet interface, MII mode (see <a href="#">Section 5.2 "ETHERNET Configuration"</a> )
Y6, R184, R186	N.P	External 13 MHz oscillator (option) for the on-board video composite encoder
TP1		GND Test point
TP2		GND Test point
TP3		GND Test point
TP4		GND Test point

## 5.5 PIO Configuration

### 5.5.1 Peripheral Signals Multiplexing on I/O Lines

The AT91SAM9M10 product features 5 PIO controllers, PIOA, PIOB, PIOC, PIOD and PIOE, which multiplex the I/O lines of the peripheral set. Each PIO Controller controls up to 32 lines. Each line can be assigned to one of two peripheral functions, A or B. The multiplexing tables in the following paragraphs define how the I/O lines of peripherals A and B are multiplexed on the PIO Controllers.

### 5.5.2 Multiplexing on PIO Controller A (PIOA)

"R.Select" = connection selectable via an on-board resistor (default not populated)



## Configuration

**Table 5-4.** PIO Multiplexing Port A

I/O	Peripheral A	Peripheral B		Function and Comments	Power
PA0	MCI0_CK	TCLK3		MMCI0 Clock	VDDIOP0
PA1	MCI0_CDA	TIOA3		MMCI0 Command	VDDIOP0
PA2	MCI0_DA0	TIOB3		MMCI0 Data0	VDDIOP0
PA3	MCI0_DA1	TCKL4		MMCI0 Data1	VDDIOP0
PA4	MCI0_DA2	TIOA4		MMCI0 Data2	VDDIOP0
PA5	MCI0_DA3	TIOB4		MMCI0 Data3	VDDIOP0
PA6	MCI0_DA4	ETX2		Ethernet MII	VDDIOP0
PA7	MCI0_DA5	ETX3		Ethernet MII	VDDIOP0
PA8	MCI0_DA6	ERX2		Ethernet MII	VDDIOP0
PA9	MCI0_DA7	ERX3		Ethernet MII	VDDIOP0
PA10	ETX0			Ethernet RMII Transmit data 0	VDDIOP0
PA11	ETX1			Ethernet RMII Transmit data 1	VDDIOP0
PA12	ERX0			Ethernet RMII Receive data 0	VDDIOP0
PA13	ERX1			Ethernet RMII Receive data 1	VDDIOP0
PA14	ETXEN			Ethernet RMII Transmit enable	VDDIOP0
PA15	ERXDV			Ethernet RMII Receive data valid	VDDIOP0
PA16	ERXER			Ethernet RMII Receive Error	VDDIOP0
PA17	ETXCK			Ethernet RMII Transmit Clock	VDDIOP0
PA18	EMDC			Ethernet RMII Manag.Data Clock	VDDIOP0
PA19	EMDIO			Ethernet RMII Manag.Data In/Out	VDDIOP0
PA20	TWD0			Two Wire Interface Data	VDDIOP0
PA21	TWCK0			Two Wire Interface Clock	VDDIOP0
PA22	MCI1_CDA	SCK3		MMCI1 Command	VDDIOP0
PA23	MCI1_DA0	RTS3		MMCI1 Data0	VDDIOP0
PA24	MCI1_DA1	CTS3		MMCI1 Data1	VDDIOP0
PA25	MCI1_DA2	PWM3		MMCI1 Data2	VDDIOP0
PA26	MCI1_DA3	TIOB2		MMCI1 Data3	VDDIOP0
PA27	MCI1_DA4	ETXER	R.Select	MMCI1 Data4	Ethernet MII VDDIOP0
PA28	MCI1_DA5	ERXCK	R.Select	MMCI1 Data5	Ethernet MII VDDIOP0
PA29	MCI1_DA6	ECRS	R.Select	MMCI1 Data6	Ethernet MII VDDIOP0
PA30	MCI1_DA7	ECOL	R.Select	MMCI1 Data7	Ethernet MII VDDIOP0
PA31	MCI1_CK	PCK0		MMCI1_clock	VDDIOP0

## 5.5.3 Multiplexing on PIO Controller B (PIOB)

Table 5-5. PIO Multiplexing Port B

I/O	Peripheral A	Peripheral B	Function and Comments	Power
PB0	SPI0_MISO		SPI Slave Out Serial DataFlash	VDDIOP0
PB1	SPI0_MOSI		SPI Slave In Serial DataFlash	VDDIOP0
PB2	SPI0_SPCK		SPI Serial Clock Serial DataFlash	VDDIOP0
PB3	SPI0_NPCS0		SPI Chip Select Serial DataFlash	VDDIOP0
PB4	TXD1		USART1 Transmit Data	VDDIOP0
PB5	RXD1		USART1 Receive Data	VDDIOP0
PB6	TXD2		User Push Button Right click	VDDIOP0
PB7	RXD2		User Push Button Left click	VDDIOP0
PB8	TXD3	ISI_D8	Image Sensor Data 8	VDDIOP2
PB9	RXD3	ISI_D9	Image Sensor Data 9	VDDIOP2
PB10	TWD1	ISI_D10	Image Sensor Data 10	VDDIOP2
PB11	TWCK1	ISI_D11	Image Sensor Data 11	VDDIOP2
PB12	DRXD		DBGU Receive Data	VDDIOP0
PB13	DTXD		DBGU Transmit Data	VDDIOP0
PB14	SPI1_MISO		Joystick Left	VDDIOP0
PB15	SPI1_MOSI	CTS0	Joystick Right	VDDIOP0
PB16	SPI1_SPCK	SCK0	Joystick Up	VDDIOP0
PB17	SPI1_NPCS0	RTS0	Joystick Down	VDDIOP0
PB18	RXD0	SPI0_NPCS1	Joystick Push	VDDIOP0
PB19	TXD0	SPI0_NPCS2	UsbVbus	VDDIOP0
PB20	ISI_D0		Image Sensor Data 0	VDDIOP2
PB21	ISI_D1		Image Sensor Data 1	VDDIOP2
PB22	ISI_D2		Image Sensor Data 2	VDDIOP2
PB23	ISI_D3		Image Sensor Data 3	VDDIOP2
PB24	ISI_D4		Image Sensor Data 4	VDDIOP2
PB25	ISI_D5		Image Sensor Data 5	VDDIOP2
PB26	ISI_D6		Image Sensor Data 6	VDDIOP2
PB27	ISI_D7		Image Sensor Data 7	VDDIOP2
PB28	ISI_PCK		Image Sensor Data Clock	VDDIOP2
PB29	ISI_VSYNC		Image Sensor Vertical Synchro	VDDIOP2
PB30	ISI_HSYNC		Image Sensor Horizontal Synchro	VDDIOP2
PB31	ISI_MCK	PCK1	Image Sensor Reference Clock	VDDIOP2

## Configuration

### 5.5.4 Multiplexing on PIO Controller C (PIOC)

**Table 5-6.** PIO Multiplexing Port C

I/O	Peripheral A	Peripheral B		Function and Comments	Power
PC0	DQM2				VDDIOM1
PC1	DQM3				VDDIOM1
PC2	A19			Add19 NAND Flash	VDDIOM1
PC3	A20			Add20 NAND Flash	VDDIOM1
PC4	A21/NANDALE			ALE NAND Flash	VDDIOM1
PC5	A22/NANDCLE			CLE NAND Flash	VDDIOM1
PC6	A23				VDDIOM1
PC7	A24				VDDIOM1
PC8	CFCE1			Ready/Busy NAND Flash	VDDIOM1
PC9	CFCE2	RTS2			VDDIOM1
PC10	NCS4/CFCS0	TCLK2			VDDIOM1
PC11	NCS5/CFCS1	CTS2			VDDIOM1
PC12	A25/CFRNW				VDDIOM1
PC13	NCS2				VDDIOM1
PC14	NCS3/NANDCS			Chip select NAND Flash	VDDIOM1
PC15	NWAIT				VDDIOM1
PC16	D16				VDDIOM1
PC17	D17				VDDIOM1
PC18	D18				VDDIOM1
PC19	D19				VDDIOM1
PC20	D20				VDDIOM1
PC21	D21				VDDIOM1
PC22	D22				VDDIOM1
PC23	D23				VDDIOM1
PC24	D24				VDDIOM1
PC25	D25				VDDIOM1
PC26	D26				VDDIOM1
PC27	D27				VDDIOM1
PC28	D28				VDDIOM1
PC29	D29				VDDIOM1
PC30	D30				VDDIOM1
PC31	D31				VDDIOM1

## 5.5.5 Multiplexing on PIO Controller D (PIOD)

Table 5-7. PIO Multiplexing Port D

I/O	Peripheral A	Peripheral B		Function and Comments	Power
PD0	TK0	PWM3		Command LED2	VDDIOP0
PD1	TF0			Output ENA USB Host	VDDIOP0
PD2	TD0			Input FLGA USB Host	VDDIOP0
PD3	RD0			Output ENB USB Host	VDDIOP0
PD4	RK0			Input FLGB USB Host	VDDIOP0
PD5	RF0			Int. Ethernet 10/100 MDINTR	VDDIOP0
PD6	AC97RX			AC97 Receive Signal	VDDIOP0
PD7	AC97TX	TIOA5		AC97 Transmit Signal	VDDIOP0
PD8	AC97FS	TIOB5		AC97 Frame Sync Signal	VDDIOP0
PD9	AC97CK	TCLK5		AC97 Clock Signal	VDDIOP0
PD10	TD1			Card Detect MMCI0 MCI0_CD	VDDIOP0
PD11	RD1			Card Detect MMCI1 MCI1_CD	VDDIOP0
PD12	TK1	PCK0		CTRL1 Image Sensor Interface	VDDIOP0
PD13	RK1			CTRL2 Image Sensor Interface	VDDIOP0
PD14	TF1			GPIO1 Large LCD (connector)	VDDIOP0
PD15	RF1			GPIO2 Large LCD (connector)	VDDIOP0
PD16	RTS1			USART1 Request to Send	VDDIOP0
PD17	CTS1			USART1 Clear To Send	VDDIOP0
PD18	SPI1_NPCS2	IRQ			VDDIOP0
PD19	SPI1_NPCS3	FIQ			VDDIOP0
PD20	TIOA0		TSAD0	Touch screen X_Right	VDDANA
PD21	TIOA1		TSAD1	Touch screen X_Left	VDDANA
PD22	TIOA2		TSAD2	Touch screen Y_Up	VDDANA
PD23	TCLK0		TSAD3	Touch screen Y_Down	VDDANA
PD24	SPI0_NPCS1	PWM0	GPAD4	General purpose A/D4	VDDANA
PD25	SPI0_NPCS2	PWM1	GPAD5	General purpose A/D5	VDDANA
PD26	PCK0	PWM2	GPAD6	General purpose A/D6	VDDIOP0
PD27	PCK1	SPI0_NPCS3	GPAD7	General purpose A/D7	VDDIOP0
PD28	TSADTRG	SPI1_NPCS1		USB Plug-ID IDUSB	VDDIOP0
PD29	TCLK1	SCK1		MCI1_WP	VDDIOP0
PD30	TIOB0	SCK2		Command Power Led	VDDIOP0
PD31	TIOB1	PWM1		Command LED1	VDDIOP0

## Configuration

### 5.5.6 Multiplexing on PIO Controller E (PIOE)

**Table 5-8.** PIO Multiplexing Port E

I/O	Peripheral A	Peripheral B		Function and Comments	Power
PE0	LCDPWR	PCK0		LCD Panel Pow.Enab.Ctrl	VDDIOP1
PE1	LCDMOD			LCD Modulation Signal	VDDIOP1
PE2	LCDCC			LCD Contrast Control	VDDIOP1
PE3	LCDVSYNC			LCD Vertical Synch.	VDDIOP1
PE4	LCDHSYNC			LCD Horizontal Synch.	VDDIOP1
PE5	LCDDOTCK			LCD Dot Clock	VDDIOP1
PE6	LCDDEN			LCD Data Enable	VDDIOP1
PE7	LCDD0	LCDD2		LCD-Red0	VDDIOP1
PE8	LCDD1	LCDD3		LCD-Red1	VDDIOP1
PE9	LCDD2	LCDD4		LCD-Red2	VDDIOP1
PE10	LCDD3	LCDD5		LCD-Red3	VDDIOP1
PE11	LCDD4	LCDD6		LCD-Red4	VDDIOP1
PE12	LCDD5	LCDD7		LCD-Red5	VDDIOP1
PE13	LCDD6	LCDD10		LCD-Red6	VDDIOP1
PE14	LCDD7	LCDD11		LCD-Red7	VDDIOP1
PE15	LCDD8	LCDD12		LCD-Green0	VDDIOP1
PE16	LCDD9	LCDD13		LCD-Green1	VDDIOP1
PE17	LCDD10	LCDD14		LCD-Green2	VDDIOP1
PE18	LCDD11	LCDD15		LCD-Green3	VDDIOP1
PE19	LCDD12	LCDD18		LCD-Green4	VDDIOP1
PE20	LCDD13	LCDD19		LCD-Green5	VDDIOP1
PE21	LCDD14	LCDD20		LCD-Green6	VDDIOP1
PE22	LCDD15	LCDD21		LCD-Green7	VDDIOP1
PE23	LCDD16	LCDD22		LCD-Blue0	VDDIOP1
PE24	LCDD17	LCDD23		LCD-Blue1	VDDIOP1
PE25	LCDD18			LCD-Blue2	VDDIOP1
PE26	LCDD19			LCD-Blue3	VDDIOP1
PE27	LCDD20			LCD-Blue4	VDDIOP1
PE28	LCDD21			LCD-Blue5	VDDIOP1
PE29	LCDD22			LCD-Blue6	VDDIOP1
PE30	LCDD23			LCD-Blue7	VDDIOP1
PE31	PWM2	PCK1		AC97 External Clock	VDDIOP1



### 6.1 Power Supply

The SAM9M10-G45-EK evaluation board can be powered from a DC 5V power supply via the external power supply jack (J2) shown in [Figure 6-1](#). The positive pole must be on J2 center pin.

**Figure 6-1.** Power Supply Connector J2

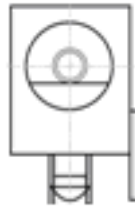

**Table 6-1.** Power Supply Connector J2 Signal Description

Pin	Mnemonic	Signal description
1	Center	+5 VCC
2	Gnd	

### 6.2 RS232 Connector with RTS/CTS Handshake Support

Connector J11 is the COM1 connector.

**Figure 6-2.** RS232 COM1 Connector J11

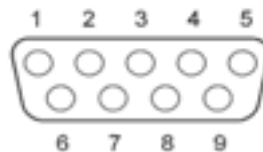
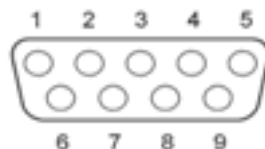

**Table 6-2.** Serial COM1 Connector J11 Signal Descriptions

Pin	Mnemonic	Signal description
1, 4, 6, 9	NC	NO CONNECTION
2	TXD TRANSMITTED DATA	RS232 serial data output signal
3	RXD RECEIVED DATA	RS232 serial data input signal
5	GND	GROUND
7	RTS READY TO SEND	Active-positive RS232 input signal
8	CTS CLEAR TO SEND	Active-positive RS232 output signal

### 6.3 DBGU

Connector J10 is the DBGU connector.

**Figure 6-3.** RS232 DBGU Connector J10**Table 6-3.** RS232 DBGU Connector J10 Signal Descriptions

Pin	Mnemonic	Signal description
1, 4, 6, 7, 8, 9	NC	NO CONNECTION
2	TXD TRANSMITTED DATA	RS232 serial data output signal
3	RXD RECEIVED DATA	RS232 serial data input signal
5	GND	GROUND

## 6.4 Ethernet

Connector J15 is the RJ-45 Ethernet Connector.

**Figure 6-4.** Ethernet RJ45 Connector J15

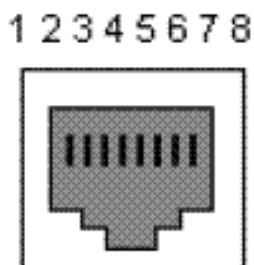

**Table 6-4.** Ethernet RJ45 Connector J15 Signal Descriptions

Pin	Mnemonic	Pin	Mnemonic
1	TxData+ DIFFERENTIAL OUTPUT PLUS	2	Txdata- DIFFERENTIAL OUTPUT MINUS
3	RxData+ DIFFERENTIAL INPUT PLUS	4	Shield
5	Shield	6	RxData- DIFFERENTIAL INPUT MINUS
7	Shield	8	Shield

## 6.5 USB Host

Connector J12 is the USB Host connector.

**Figure 6-5.** USB Host type A connector J12

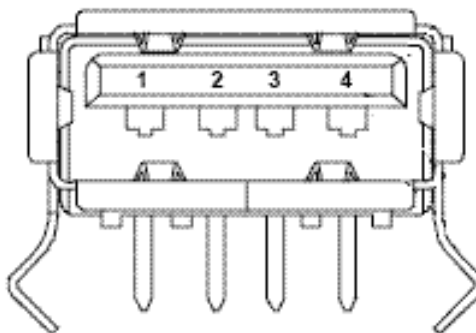

**Table 6-5.** USB Host Type A Connector J12 Signal Descriptions

Pin	Mnemonic	Signal description
1	Vbus	5v power
2	DM	Data minus
3	DP	Data plus
4	Gnd	Ground
5	Shield	Shield

## 6.6 USB Host/Device

Connector J14 is the USB Host/Device connector.

**Figure 6-6.** USB Host/Device Micro AB connector J14



**Table 6-6.** USB Host/Device MicroAB Connector J14 Signal Descriptions

Pin	Mnemonic	Signal description
1	Vbus	5v power
2	DM	Data minus
3	DP	Data plus
4	ID	On the Go Identification
5	Gnd	Ground

## 6.7 JTAG Debugging Connector

Connector J13 is the JTAG/ICE connector.

A SAM-ICE connector is a 20-way Insulation Displacement Connector (IDC) keyed box header (2.54 mm male) that mates with IDC sockets mounted on a ribbon cable.

**Figure 6-7.** JTAG/ICE Connector J13

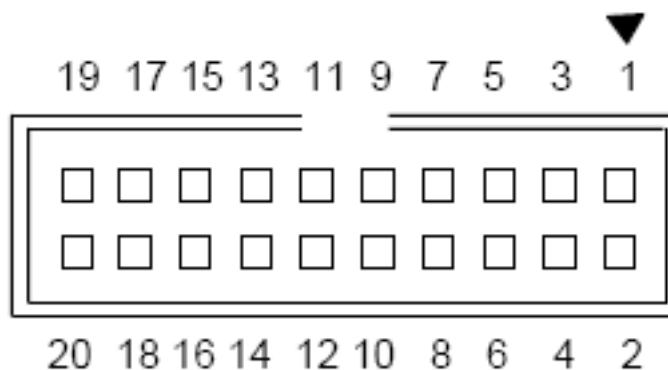

**Table 6-7.** JTAG/ICE Connector J13 Signal Descriptions

Pin	Mnemonic	Description
1	VTref. 3.3V power	This is the target reference voltage. It is used to check if the target has power, to create the logic-level reference for the input comparators, and to control the output logic levels to the target. It is normally fed from VDD on the target board and must not have a series resistor.
2	Vsupply. 3.3V power	This pin is not connected in SAM-ICE. It is reserved for compatibility with other equipment. Connect to VDD or leave open in target system.
3	nTRST TARGET RESET - Active-low output signal that resets the target	JTAG Reset. Output from SAM-ICE to the Reset signal on the target JTAG port. Typically connected to nTRST on the target CPU. This pin is normally pulled HIGH on the target to avoid unintentional resets when there is no connection.
4	GND	Common ground
5	TDI TEST DATA INPUT - Serial data output line, sampled on the rising edge of the TCK signal.	JTAG data input of target CPU. It is recommended that this pin is pulled to a defined state on the target board. Typically connected to TDI on target CPU.
6	GND	Common ground
7	TMS TEST MODE SELECT	JTAG mode set input of target CPU. This pin should be pulled up on the target. Typically connected to TMS on target CPU. Output signal that sequences the target's JTAG state machine, sampled on the rising edge of the TCK signal.
8	GND	Common ground
9	TCK TEST CLOCK - Output timing signal, for synchronizing test logic and control register access.	JTAG clock signal to target CPU. It is recommended that this pin is pulled to a defined state on the target board. Typically connected to TCK on target CPU.
10	GND	Common ground
11	RTCK - Input Return test clock signal from the target.	Some targets must synchronize the JTAG inputs to internal clocks. To assist in meeting this requirement, a returned and retimed TCK can be used to dynamically control the TCK rate. SAM-ICE supports adaptive clocking which waits for TCK changes to be echoed correctly before making further changes. Connect to RTCK if available, otherwise to GND
12	GND	Common ground
13	TDO JTAG TEST DATA OUTPUT - Serial data input from the target.	JTAG data output from target CPU. Typically connected to TDO on target CPU.
14	GND	Common ground
15	nSRST RESET	Active-low reset signal. Target CPU reset signal
16	GND	Common ground
17	RFU	This pin is not connected in SAM-ICE.
18	GND	Common ground
19	RFU	This pin is not connected in SAM-ICE
20	GND	Common ground

## 6.8 SD/MMC- MCI0

Connector J6 is the SD/MMC connector.

**Figure 6-8.** SD/MMC0 Connector J6

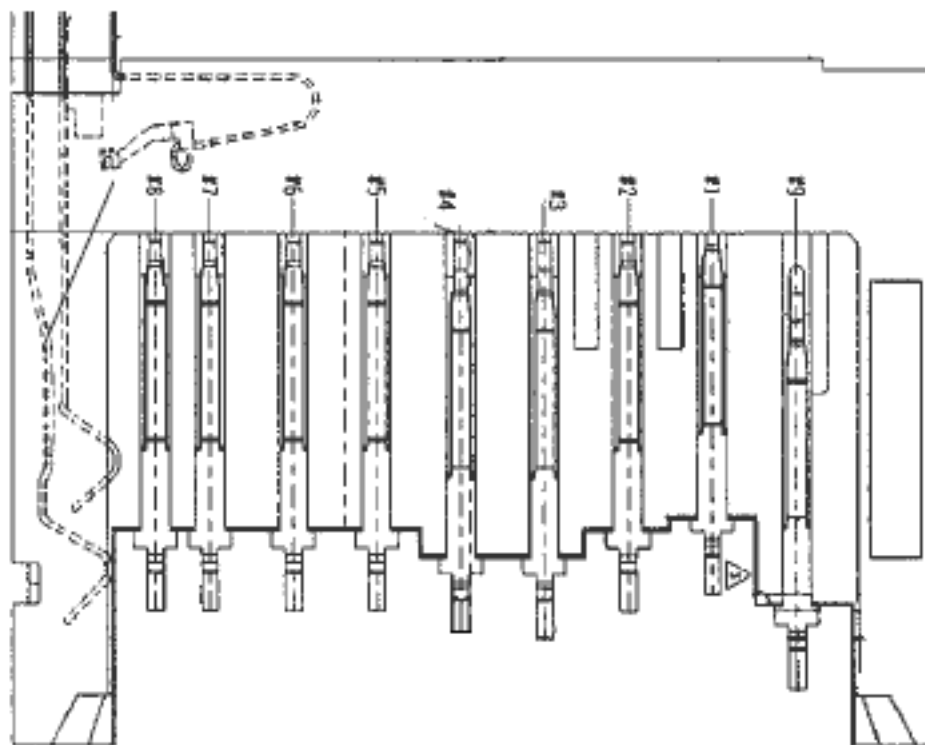

**Table 6-8.** SD/MMC0 Connector J6 Signal Descriptions

Pin	Mnemonic	Pin	Mnemonic
1	RSV/DAT3	2	CDA
3	GND	4	VCC
5	CLK	6	GND
7	DAT0	8	DAT1
9	DAT2	10	Card Detect
11	GND	12	

## 6.9 SD/MMC- MCI1

Connector J5 is the SD/MMC connector.

**Figure 6-9.** SD/MMC1 Connector J5

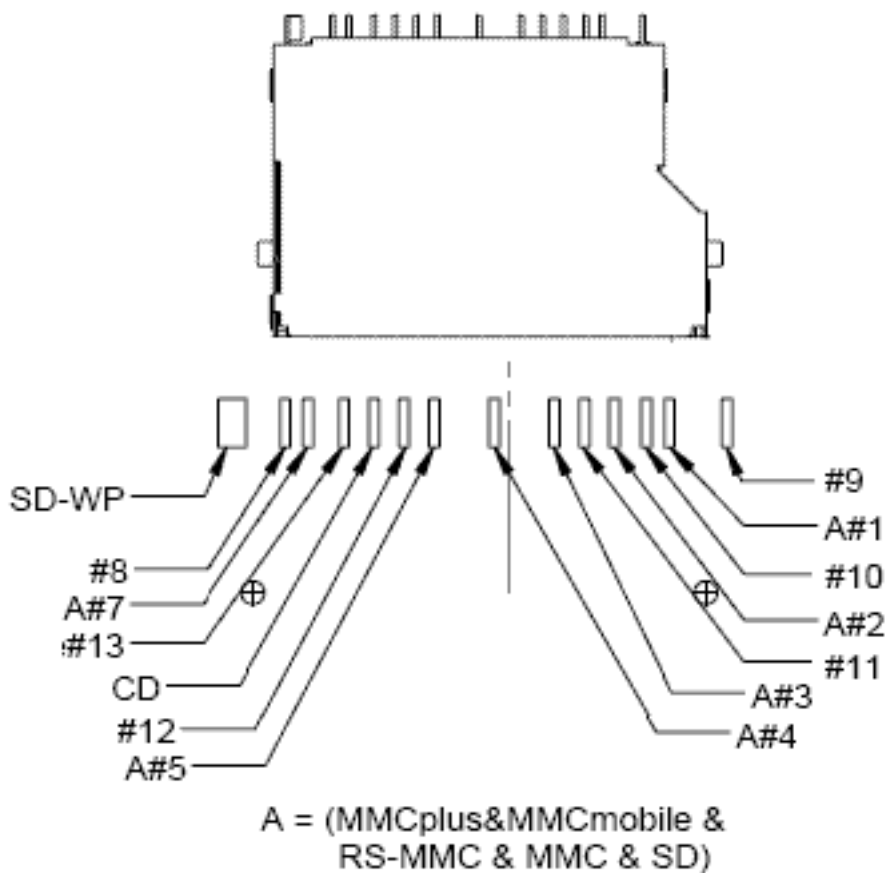

**Table 6-9.** SD/MMC1 Connector J5 Signal Descriptions

Pin	Mnemonic	Pin	Mnemonic
1	RSV/DAT3	2	CMD
3	GND	4	VCC
5	CLK	6	
7	DAT0	8	DAT1
9	DAT2	10	DAT3
11	DAT4	12	DAT5
13	DAT6	14	DAT7

## 6.10 AC97

- Connector J7 is the Headphone connector.
- Connector J8 is the Line In connector.
- Connector J9 is the Microphone Input.
- Connector JP15 is the Speaker Output connector

**Figure 6-10.** Audio Connector J7, J8, J9

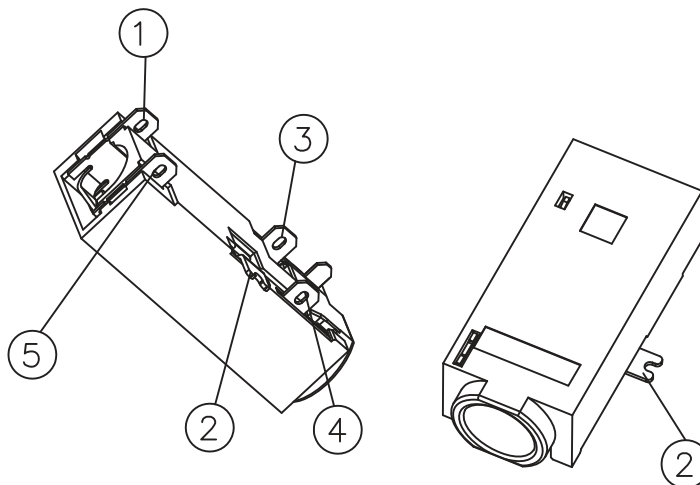

**Table 6-10.** J7, J8, J9 Signal Description

Pin	Mnemonic
1	Signal
2	Signal
3	Gnd

**Table 6-11.** Speaker JP15 Signal Descriptions

Pin	Mnemonic
1	Speaker bridge output A
2	Speaker bridge output B



## 6.11 Image Sensor - ISI

Connector J17 is the ISI connector.

**Figure 6-11.** ISI Connector J17

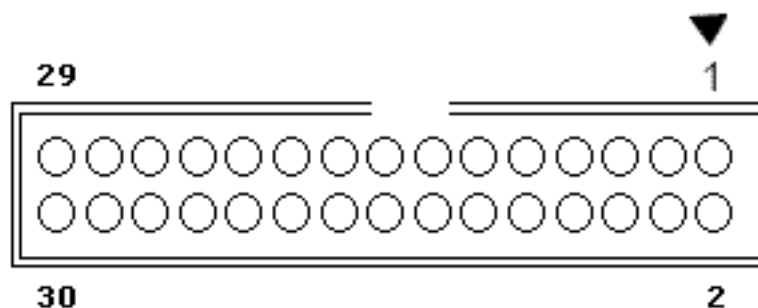

**Table 6-12.** ISI Connector J17 Signal Descriptions

Pin	Mnemonic	Pin	Mnemonic
1	VCC 3v3	2	Gnd
3	VCC 3v3	4	Gnd
5	Ctrl1	6	Ctrl2
7	SCL	8	SDA
9	Gnd	10	ISI_MCK
11	Gnd	12	ISI_VSYNC
13	Gnd	14	ISI_HSYNC
15	Gnd	16	ISI_PCK
17	Gnd	18	ISI_Data0
19	ISI_Data1	20	ISI_Data2
21	ISI_Data3	22	ISI_Data4
23	ISI_Data5	24	ISI_Data6
25	ISI_Data7	26	ISI_Data8
27	ISI_Data9	28	ISI_Data10
29	ISI_Data11	30	Gnd

## 6.12 Video

Connector J20 is the Video connector

**Figure 6-12.** Video Connector J20



**Table 6-13.** Video Connector J20 Signal Description

Pin	Mnemonic	Signal description
1	Center	Composite video signal output

## 6.13 Display Devices

### 6.13.1 TFT LCD

Connector J24 is the TFT-LCD connector.

**Figure 6-13.** TFT LCD Connector J24

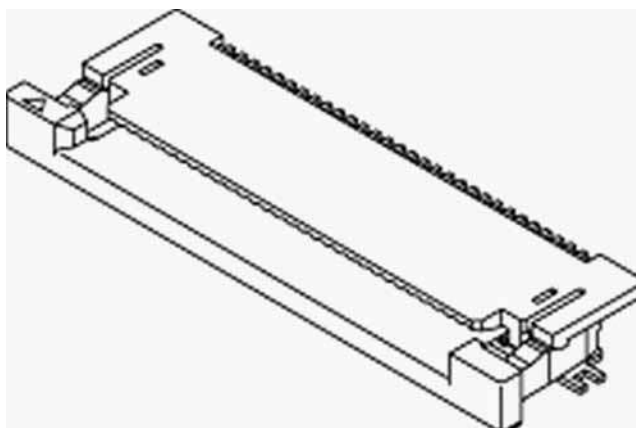

**Table 6-14.** TFT LCD Connector J24 Signal Descriptions

Pin	Mnemonic	Pin	Mnemonic
1	VLED-	2	VLED+
3	GND	4	VDD 3V3
5	R0	6	R1
7	R2	8	R3
9	R4	10	R5

**Table 6-14.** TFT LCD Connector J24 Signal Descriptions

Pin	Mnemonic	Pin	Mnemonic
11	R6	12	R7
13	G0	14	G1
15	G2	16	G3
17	G4	18	G5
19	G6	20	G7
21	B0	14	B1
23	B2	16	B3
25	B4	18	B5
27	B6	20	B7
29	GND	30	DCLK
31	DISPON	32	HSYNC
33	VSYNC	34	LCDEN
35	NO CONNECT	36	GND
37	X2	38	Y1
39	X1	40	Y2

## 6.14 LCD Extension

Connectors J23 and J18 are for an optional LCD extension (not populated).

**Table 6-15.** Connector J23 Signal Description for an LCD Extension

Pin		Mnemonic	Pin		Mnemonic
1	PE8	RED Data Signal	2	PE7	RED Data Signal (LSB)
3	PE10	RED Data Signal	4	PE9	RED Data Signal
5	PE12	RED Data Signal	6	PE11	RED Data Signal
7	PE14	RED Data Signal (MSB)	8	PE13	RED Data Signal
9	PE16	GREEN Data Signal	10	PE15	GREEN Data Signal (LSB)
11	PE18	GREEN Data Signal	12	PE17	GREEN Data Signal
13	PE20	GREEN Data Signal	14	PE19	GREEN Data Signal
15	PE22	GREEN Data Signal (MSB)	16	PE21	GREEN Data Signal
17	PE24	BLUE Data Signal	18	PE23	BLUE Data Signal (LSB)
19	PE26	BLUE Data Signal	20	PE25	BLUE Data Signal
21	PE28	BLUE Data Signal	22	PE27	BLUE Data Signal
23	PE30	BLUE Data Signal (MSB)	24	PE29	BLUE Data Signal
25	PE4	LCDHSYNC	26	PE3	LCDVSYNC
27	PE5	LCDDOTCK	28	GND	(0V)
29	GND	(0V)	30	NC	



**Table 6-15.** Connector J23 Signal Description for an LCD Extension

Pin		Mnemonic	Pin		Mnemonic
31	PE6	LCDDEN	32	PE2	LCDDCC
33	PE0	DISPON	34	PE1	LCDDMOD
35	PD14	GPIO1	36	PD15	GPIO2
37	GND	(0V)	38	GND	(0V)
39	VCC	+3V3 power source	40	NC	

**Table 6-16.** Connector J18 Signal Description for an LCD Extension

Pin		Mnemonic	Pin		Mnemonic
1	XM	AD1XM	2	XP	AD0XP
3	YM	AD3YM	4	YP	AD2YP
5	GND	(0V)	6	GND	(0V)
7	PD25	PD25	8	PD24	PD24
9	PD27	PD27	10	PD26	PD26
11	PD19	PD19	12	PD18	PD18
13	GND	(0V)	14	GND	(0V)
15	GND	(0V)	16		+5V
17	GND	(0V)	18	GND	(0V)
19	VCC	+3V3 power source	20	VCC	+3V3 power source



## Section 7

---

# Schematics

---

### 7.1 Schematics

This section contains the following schematics:

- Top Level view, block architecture of the design
- Power Supply
- SAM Processor
- Bus impedance adaptor
- Main memory
- EBI memory
- MCI & TWI
- Audio AC97
- Serial interfaces
- Ethernet
- LCD
- Video interfaces and LCD extension

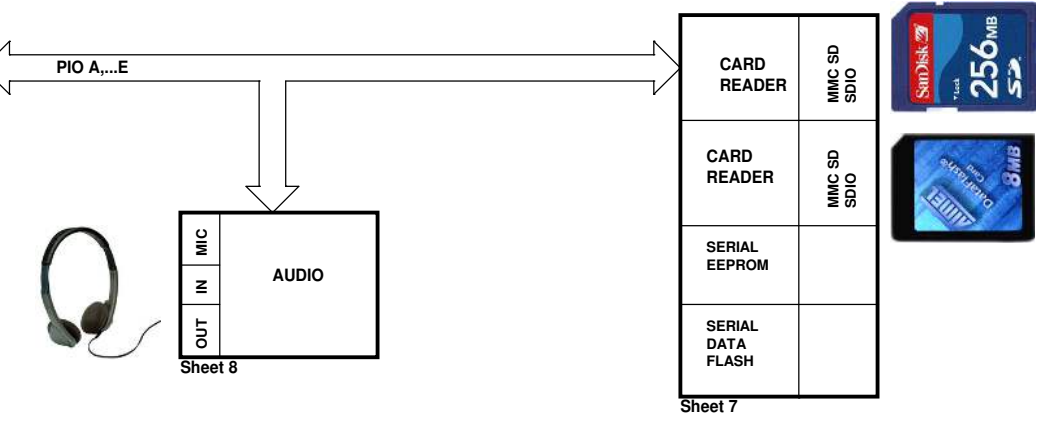
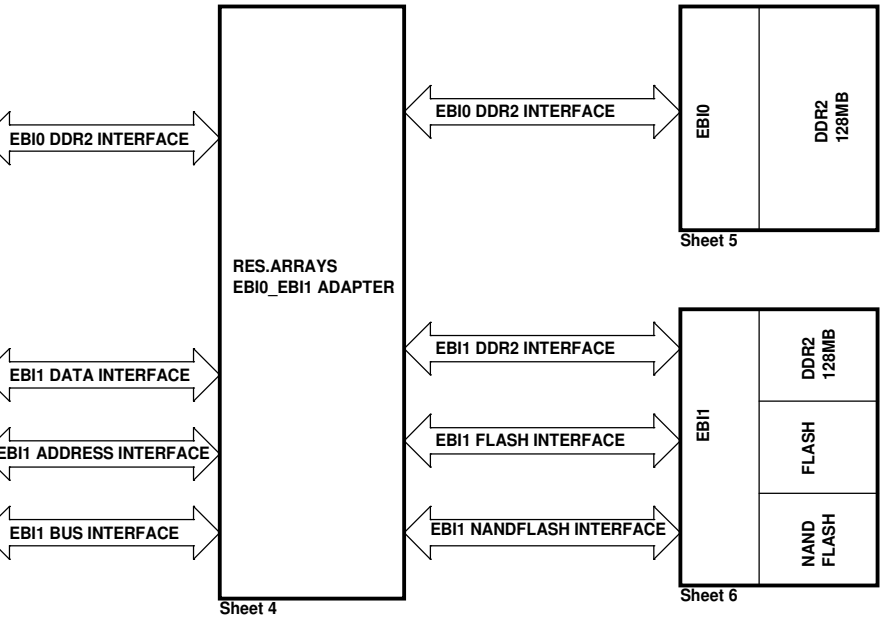
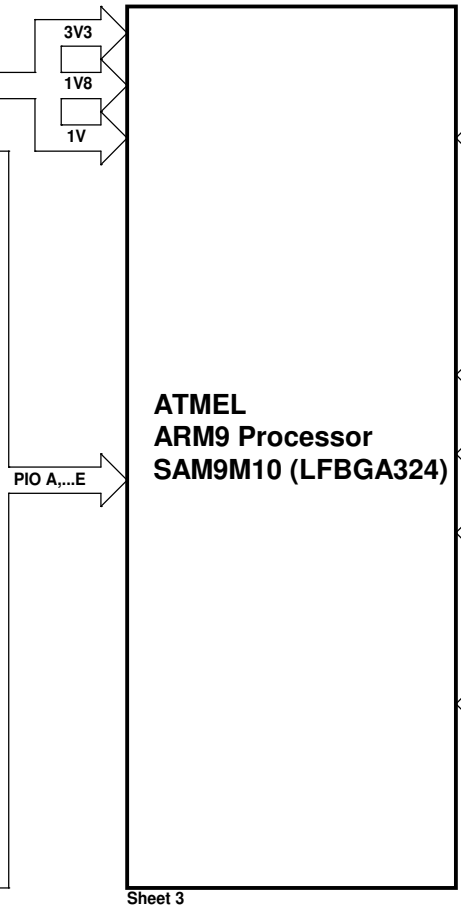
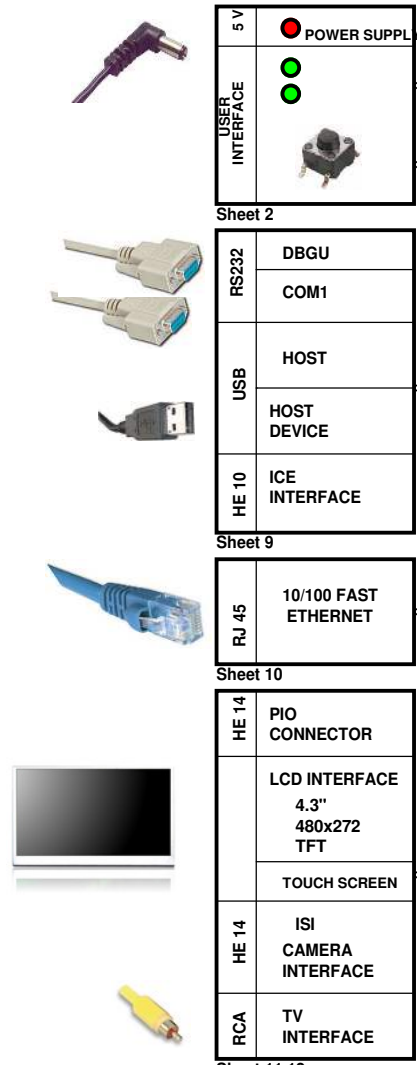

PIO MUXING															
PIO#	USAGE	PIO#	USAGE	PIO#	USAGE	PIO#	USAGE	PIO#	USAGE	PIO#	USAGE	PIO#	USAGE	PIO#	USAGE
PA0	MC10_CR	PA16	RX_ER	PB0	SPI0_MISO	PB16	BP3_UP	PC0	NOT USED	PD0	USER_LED_D6	PD16	RTS1	PE0	LCDFWR
PA1	MC10_CDA	PA17	TX_CLK	PB1	SPI0_MOSI	PB17	BP3_DOWN	PC1	NOT USED	PD1	ENA	PD17	CIS1	PE1	LCDCMD
PA2	MC10_DA0	PA18	MDC	PB2	SPI0_SPC0	PB18	BP3_PUSH	PC2	A19	PD2	FLGA	PD18	J18_12	PE2	LCDDC
PA3	MC10_DA1	PA19	MDIO	PB3	SPI0_NPCS0	PB19	VBUS	PC3	A20	PD3	ENB	PD19	J18_11	PE3	LCDSVSYNC
PA4	(MC10_DA2)	PA20	TWDO	PB4	TXD1	PB20	ISI_D0	PC4	NANDALE/A21	PD4	FLGB	PD20	AD0Xp	PE4	LCDSHSYNC
PA5	(MC10_DA3)	FA21	TWCK0	PB5	RXD1	PB21	ISI_D1	PC5	NANDCLE	PD5	MDINTR	FD21	AD1Xm	PE5	LCDDOTCK
PA6	TXD2	FA22	MC11_CDA	PB6	BP5_LEFT	PB22	ISI_D2	PC6	NOT USED	PD6	AC97RX	FD22	AD2Yp	PE6	LCDDEN
PA7	TXD3	FA23	MC11_DA0	PB7	BP4_RIGHT	PB23	ISI_D3	PC7	NOT USED	PD7	AC97TX	FD23	AD3Im	PE7	RD
PA8	RXD2	FA24	MC11_DA1	PB8	ISI_D8	PB24	ISI_D4	PC8	RDX/BSY	PD8	AC97FS	FD24	J18_8	PE8	R1
PA9	RXD3	FA25	MC11_DA2	PB9	ISI_D9	PB25	ISI_D5	PC9	NOT USED	PD9	AC97CK	FD25	J18_7	PE9	R2
PA10	TXD0	FA26	MC11_DA3	PB10	ISI_D10	PB26	ISI_D6	PC10	NOT USED	PD10	MC10_CD	FD26	J18_10	PE10	R3
PA11	TXD1	FA27	MC11_DA4/TX_ER	PB11	ISI_D11	PB27	ISI_D7	PC11	NOT USED	PD11	(MC11_CD)	FD27	J18_9	PE11	R4
PA12	RXD0	FA28	MC11_DA5/RX_CLK	PB12	DRXD	PB28	ISI_PCK	PC12	NOT USED	PD12	CTRL1	FD28	IDUSB	PE12	R5
PA13	RXD1	FA29	MC11_DA6/CRS	PB13	DTXD	PB29	ISI_VSYNC	PC13	NOT USED	PD13	CTRL2	FD29	(MC11_WP)	PE13	R6
PA14	TX_EN	PA30	MC11_DA7/COL	PB14	BP3_LEFT	PB30	ISI_HSYNC	PC14	NCS3	PD14	GPIO1	PD30	POWER_LED	PE14	R7
PA15	RX_DV	PA31	MC11_CR	PB15	BP3_RIGHT	PB31	ISI_MCK	PC15	NOT USED	PD15	GPIO2	PD31	USER_LED_D7	PE15	GG

**NOTE**  
"DNP" means the component is not populated by default

<b>ATMEL</b> ROUSSET		REV. A2		PP 08-apr-10		PP 11-FEB-10	
AT91SAM9M10-G45-EK		Derek		05-Feb-10		Derek	
TOP LEVEL		SCALE 1/1		REV. A2		SHEET 1/12	



REGULATED 5V ONLY

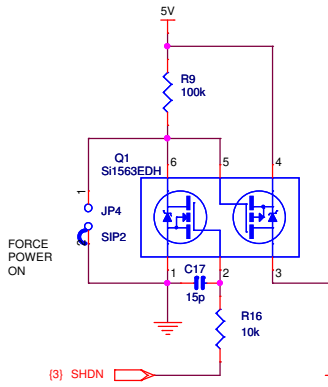
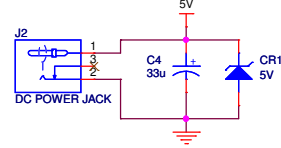

USER INTERFACE

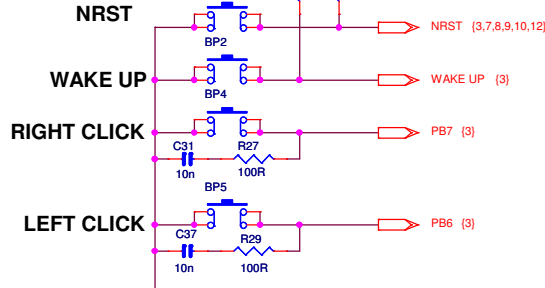
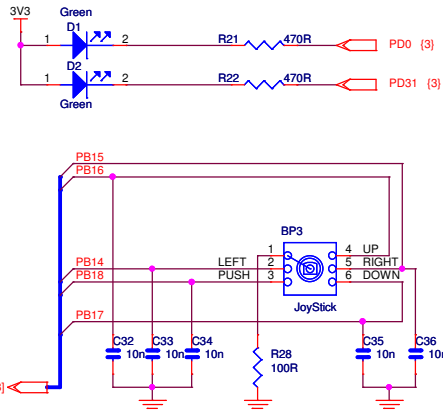
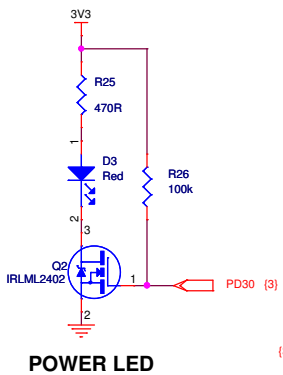

ADHESIVE FEET



GND TEST POINT

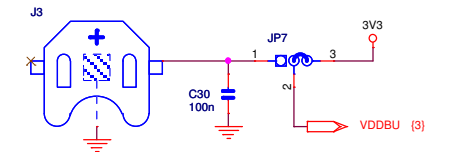
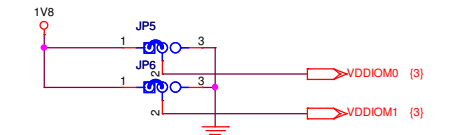
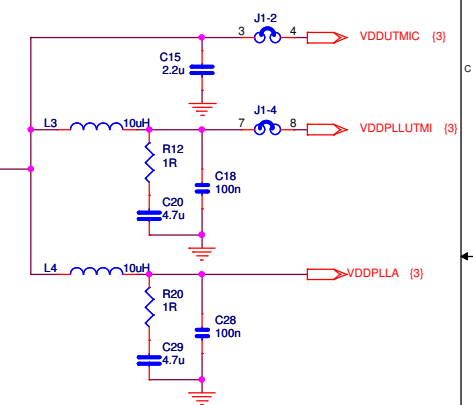
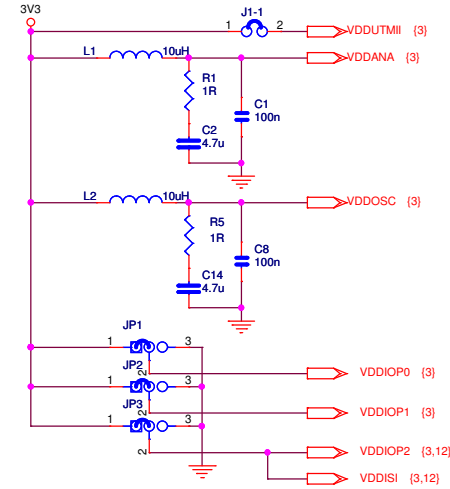
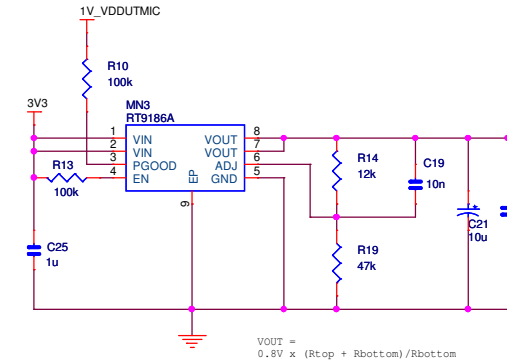
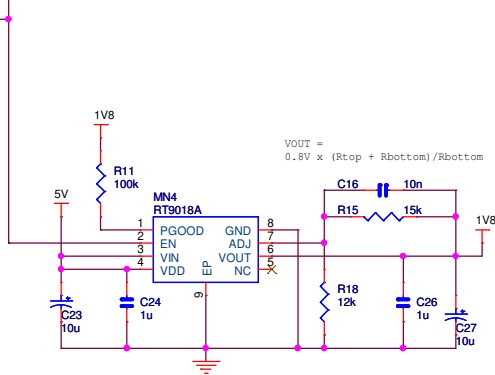
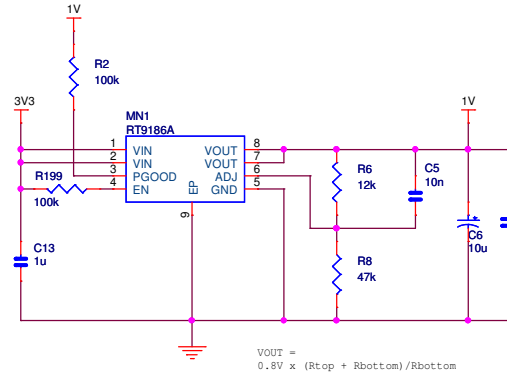
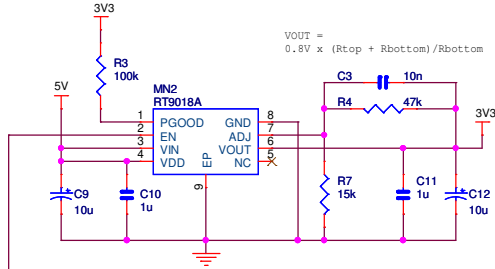
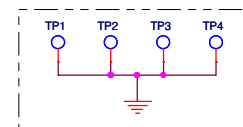

A2	PP	08-apr-10	PP	11-FEB-10	
REV	MODIF.	Derek	DES.	DATE	VER.
AT91SAM9M10-G45-EK	SCALE	1/1			REV. SHEET
POWER SUPPLY					A2 2/12

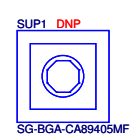
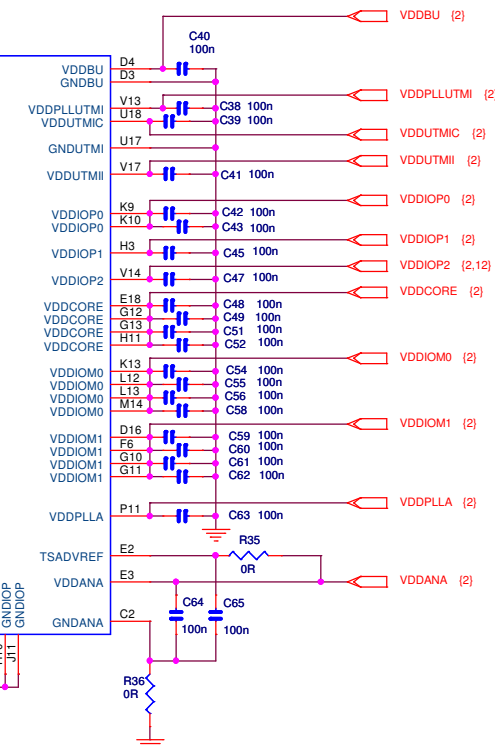
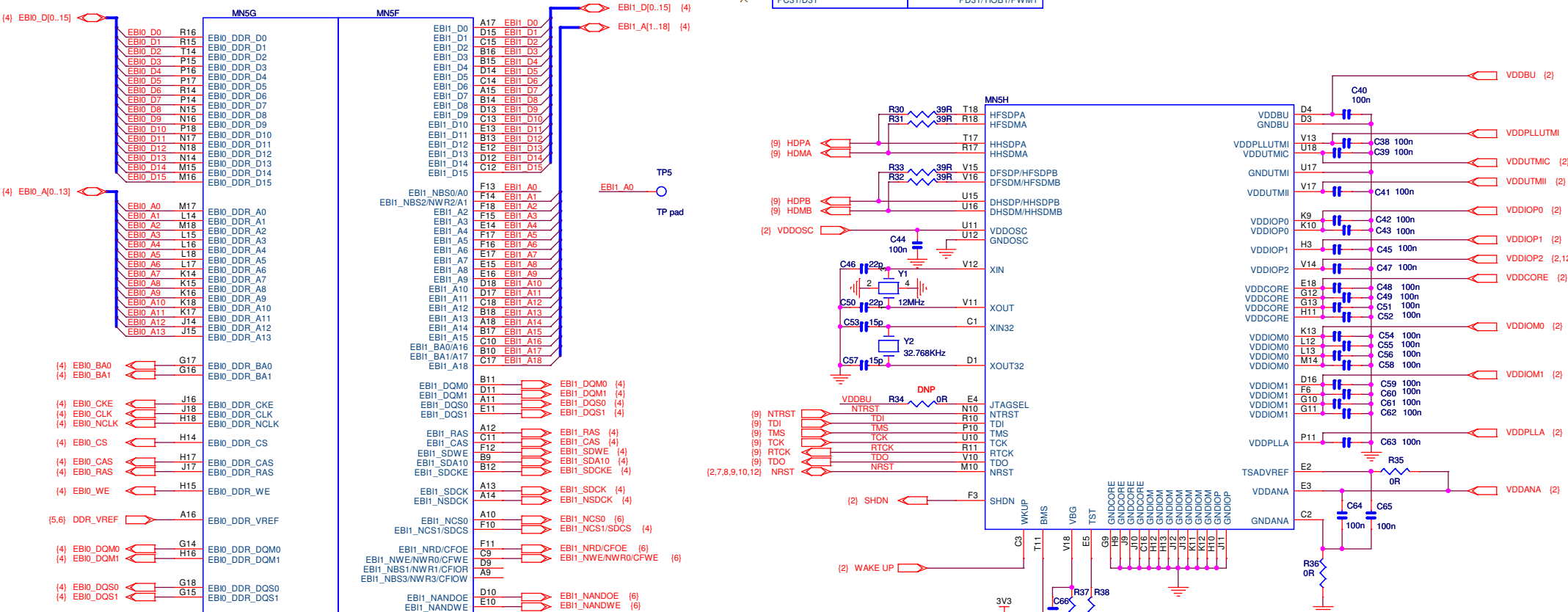
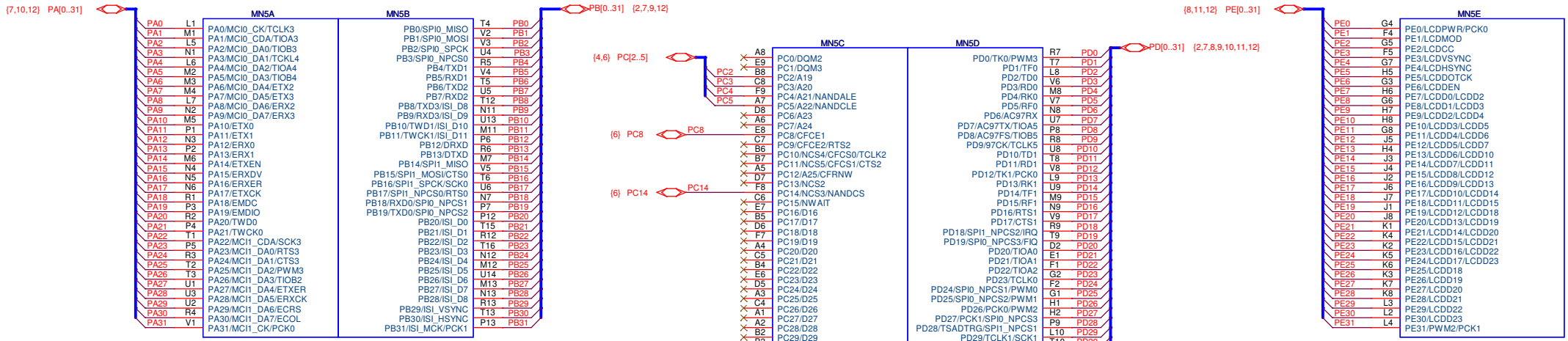

BOOT MODE SELECT  
 Opened = Internal ROM BOOT  
 Closed = NCS0

		PP 08-apr-10		PP 11-FEB-10	
		Derek 05-Feb-10		VER. DATE	
<b>AT91SAM9M10-G45-EK</b> AT91SAM9M10 chip		SCALE 1/1	REV. <b>A2</b>		SHEET 3/12



# EBI Bus Impedance Adaptor

## EBIO

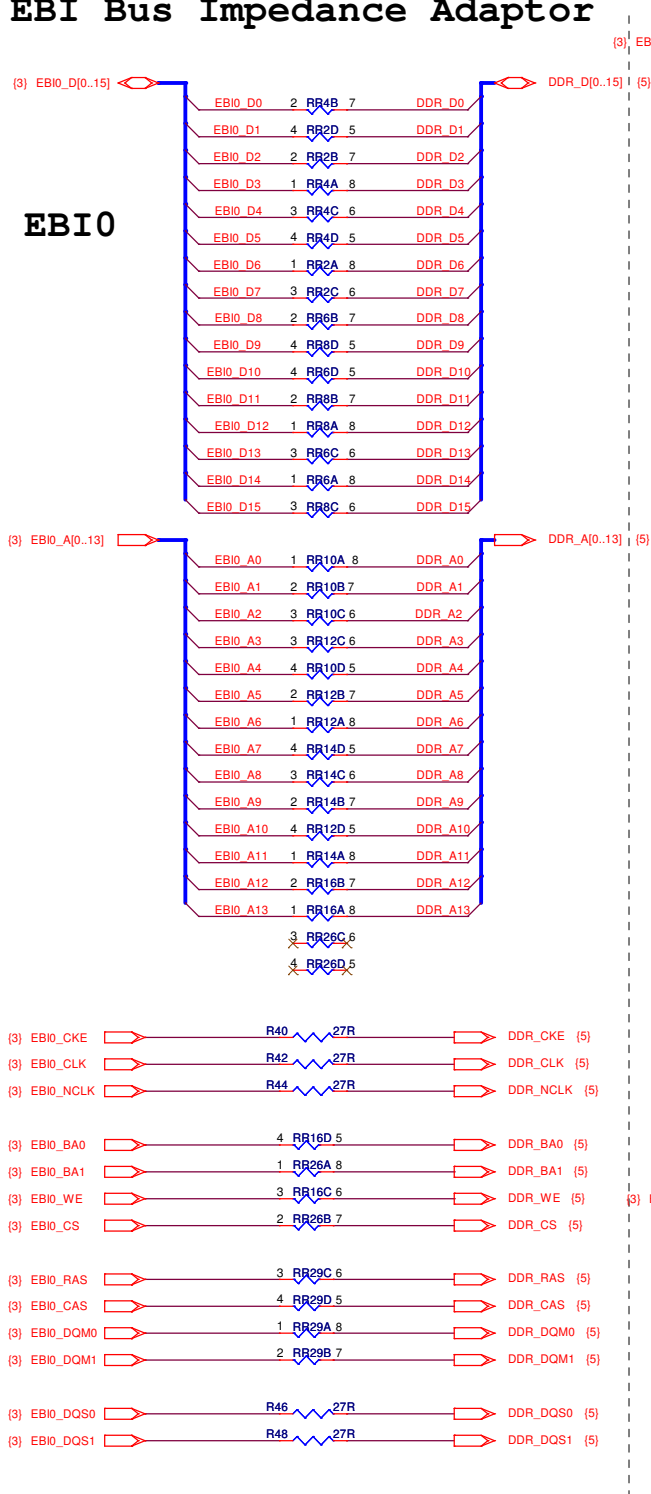

## EBI1

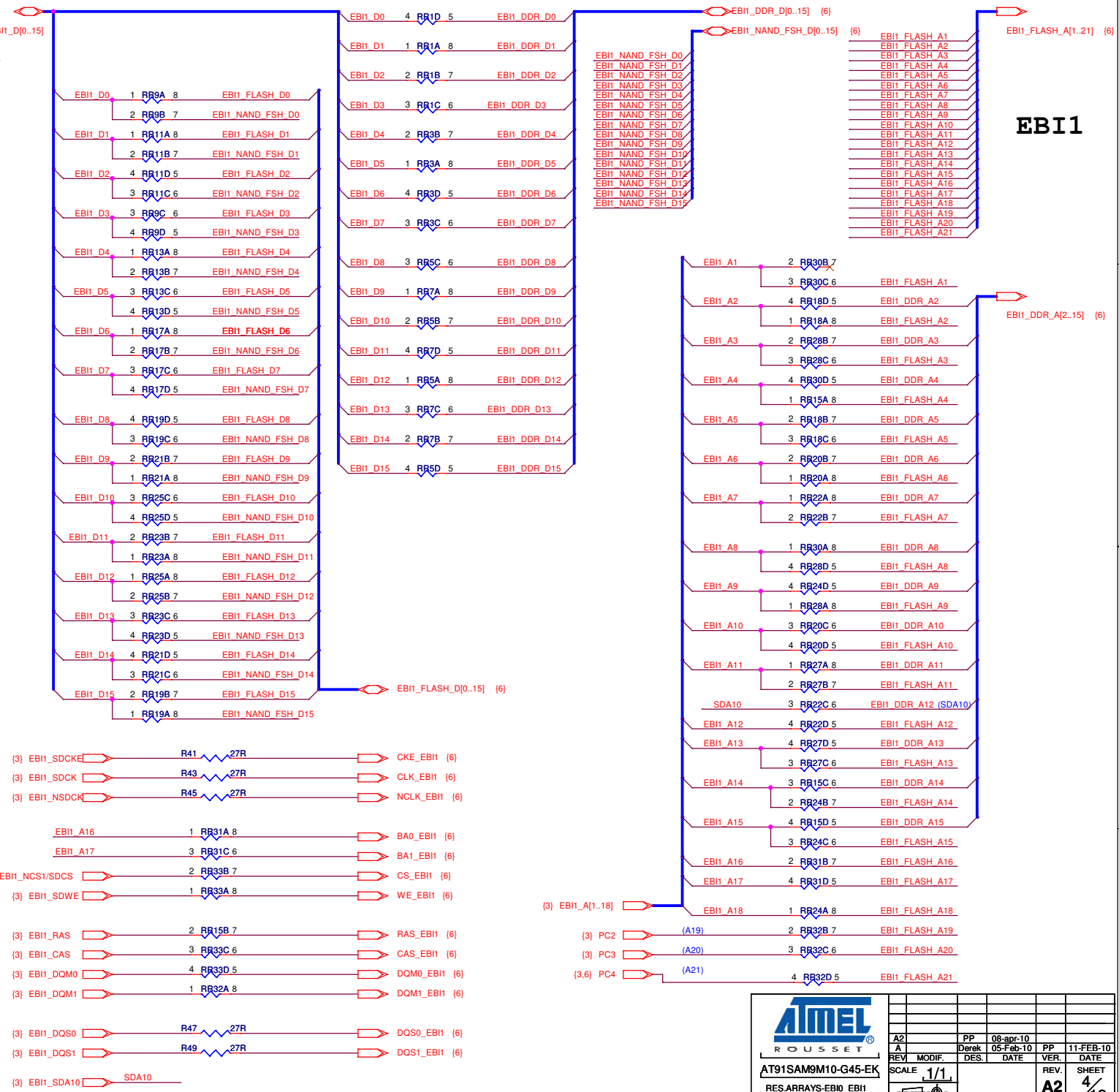

		PP 08-jan-10		PP 11-FEB-10	
		DES. Derek 05-Feb-10		DATE	
<b>AT91SAM9M10-G45-EK</b> RES.ARRAYS-EBIO_EBI1		SCALE 1/1		REV. SHEET 4/12	

The agreement is our property. Reproduction and publication without our written authorization shall expose offender to legal proceedings.

(4) DDR\_D[0..15]

(4) DDR\_A[0..13]

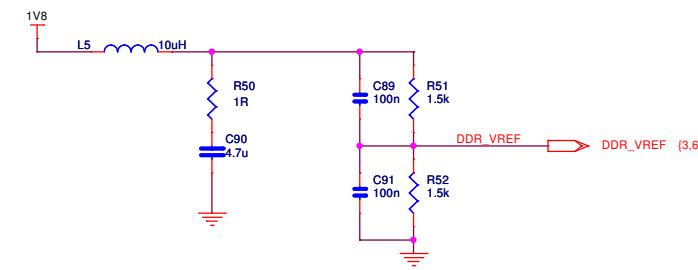
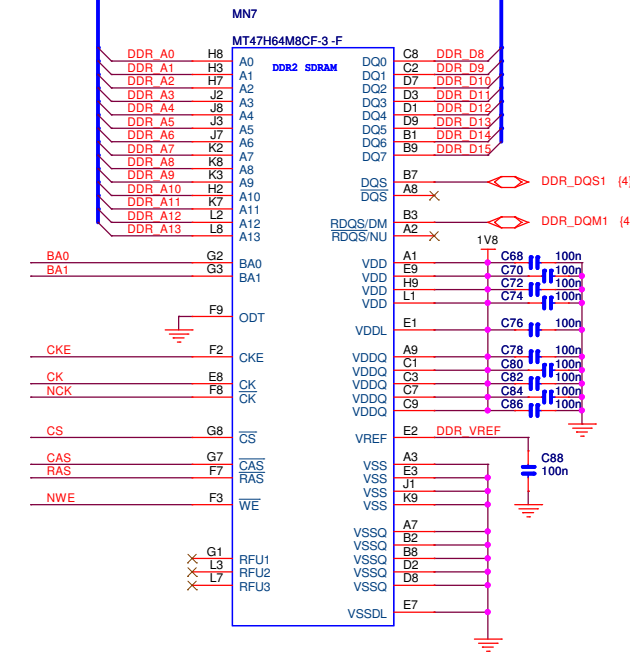
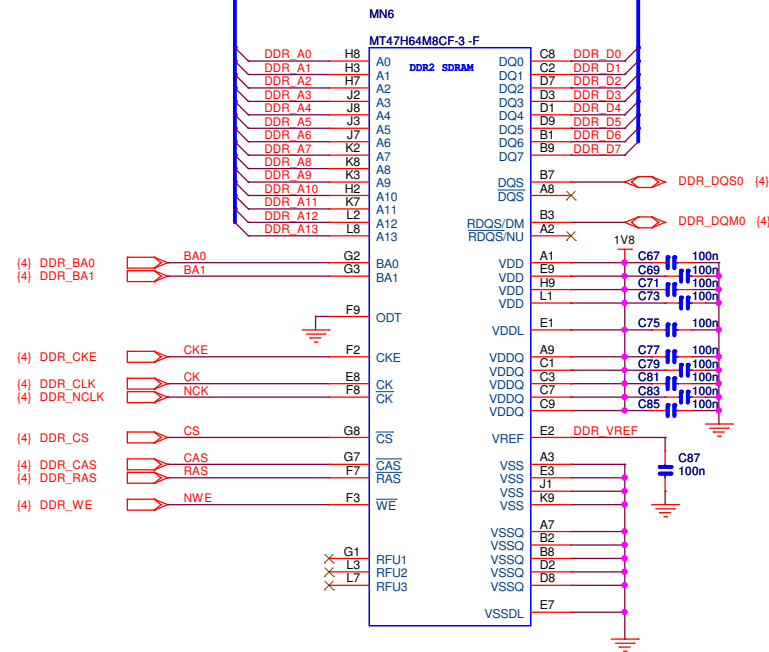

**ATMEL**  
ROUSSET

AT91SAM9M10-G45-EK  
EBI0\_DDR2

REV	MODIF.	DES.	DATE	PP	11-FEB-10
A2		Derek	05-Feb-10	PP	11-FEB-10
SCALE	1/1			REV.	SHEET
				A2	5/12

The agreement is our property. Reproduction and publication without our written authorization shall expose offender to legal proceedings.

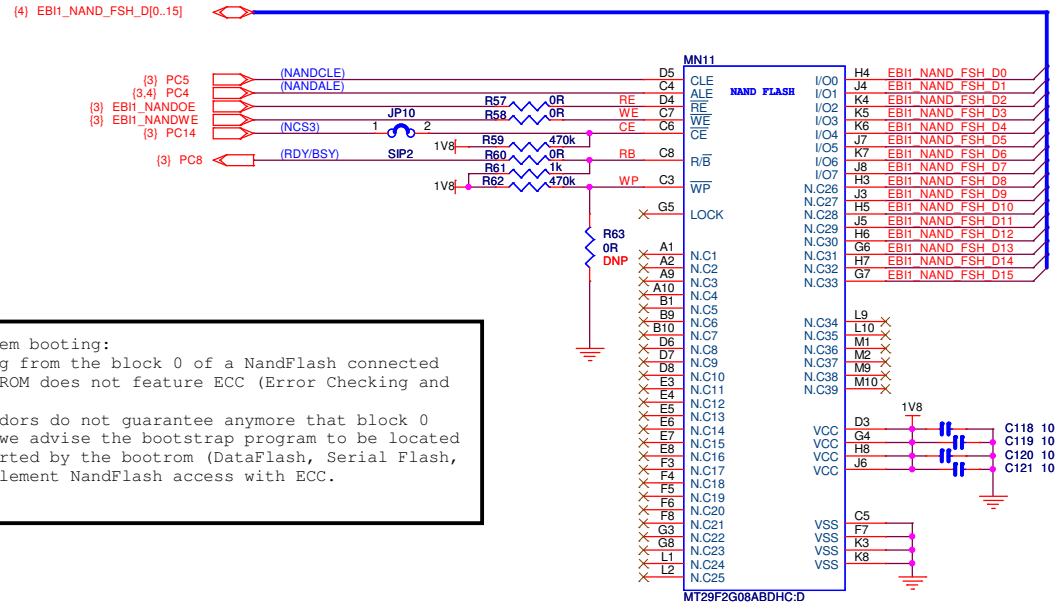
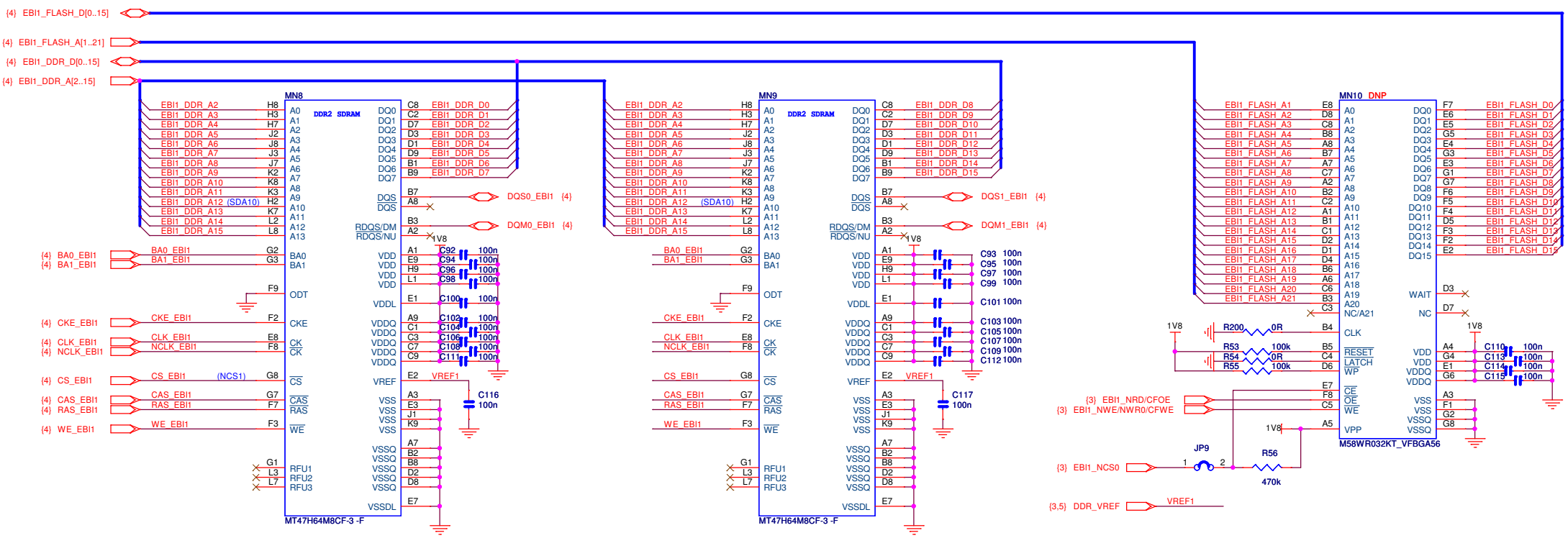

**IMPORTANT note about system booting:**  
 The bootROM allows booting from the block 0 of a NandFlash connected on CS3. However, the bootROM does not feature ECC (Error Checking and Correction) on NandFlash.  
 Most of the NandFlash vendors do not guarantee anymore that block 0 is error free. Therefore we advise the bootstrap program to be located into another device supported by the bootrom (DataFlash, Serial Flash, SDCARD or EEPROM) and implement NandFlash access with ECC.

<b>AMEL</b>					
ROUSSET					
A2	PP	08-apr-10	PP	11-FEB-10	
A	Derek	05-Feb-10	VER.	DATE	
AT91SAM9M10-G45-EK	SCALE	1/1	REV.	SHEET	
EBI1_MEMORY			A2	6/12	

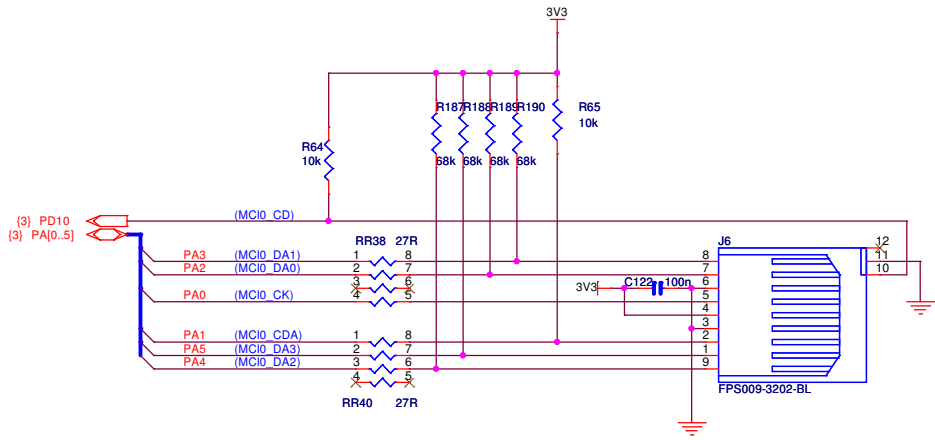

SD/MMC CARD INTERFACE - MC10

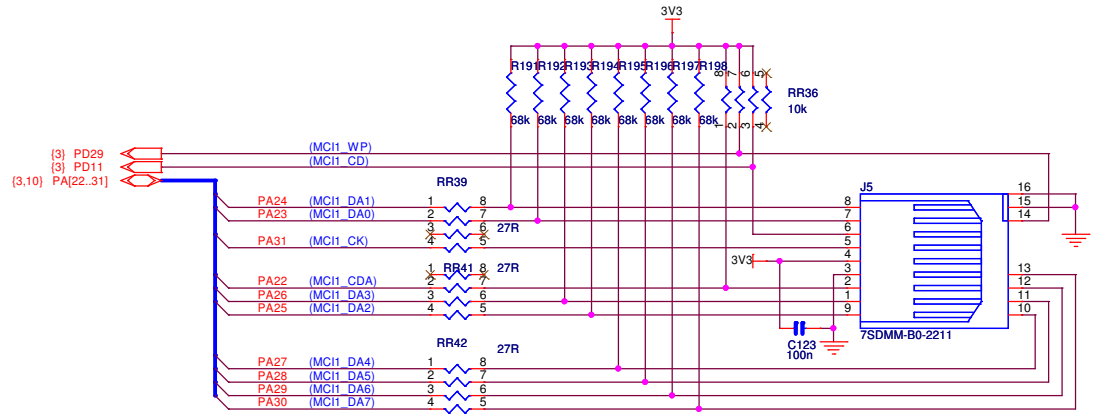

SD/MMCPlus CARD INTERFACE - MC11

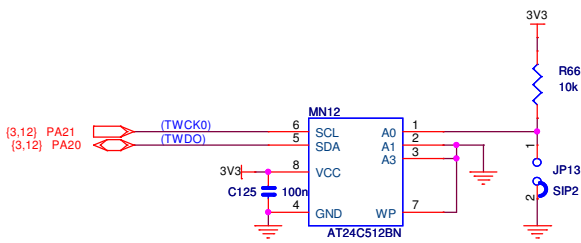

SERIAL EEPROM

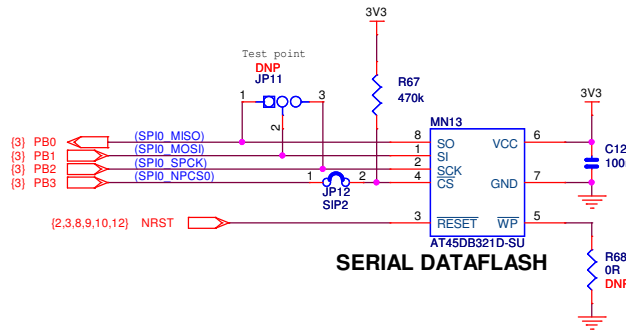

SERIAL DATAFLASH

A2	PP	08-apr-10	PP	11-FEB-10	
A	Derek	05-Feb-10	DES.	DATE	
REV.	MODIF.	DES.	DATE	VER.	DATE
AT91SAM9M10-G45-EK			SCALE	1/1	REV. A2
MCI & TWI					SHEET 7/12
<small>The agreement is our property. Reproduction and publication without our written authorization shall expose offender to legal proceedings.</small>					

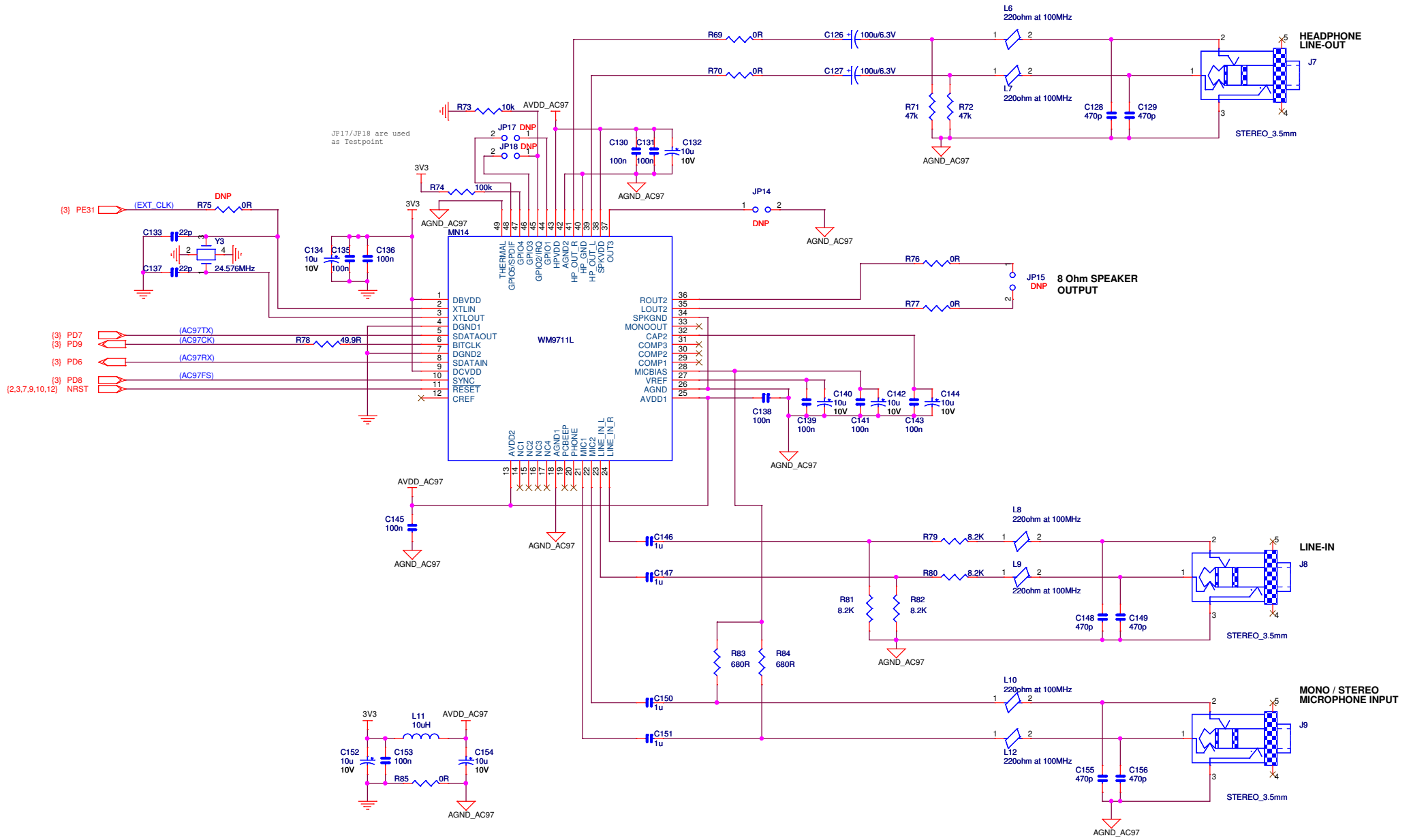

<b>ATMEL</b> ROUSSET					
A2	PP	08-apr-10		PP	11-FEB-10
REV	MODIF.	Derek	DATE	DES.	DATE
SCALE	1/1			REV.	8
AT91SAM9M10-G45-EK					SHEET
AUDIO AC97					8/12
This agreement is our property. Reproduction and publication without our written authorization shall expose offenders to legal proceedings.					

**SERIAL DEBUG PORT**

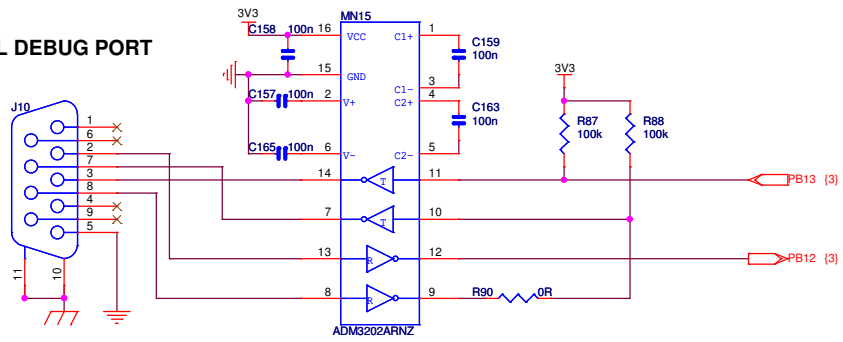

**RS232 COM PORT**

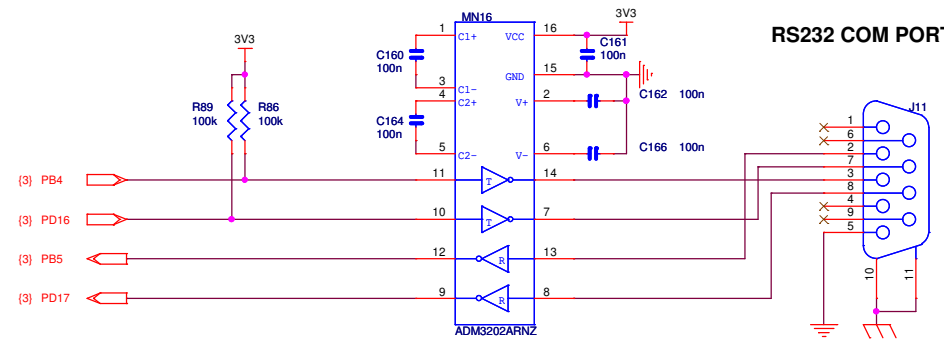

**USB HOST INTERFACE**

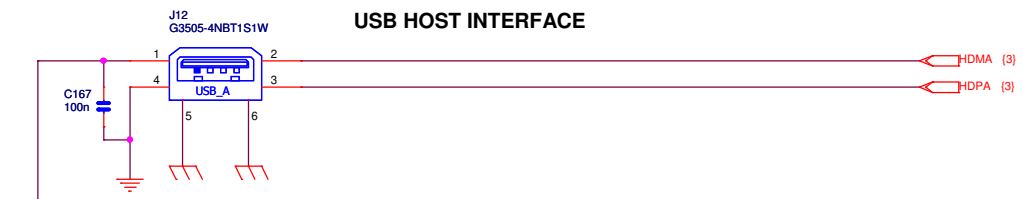

**USB HOST/DEVICE INTERFACE**

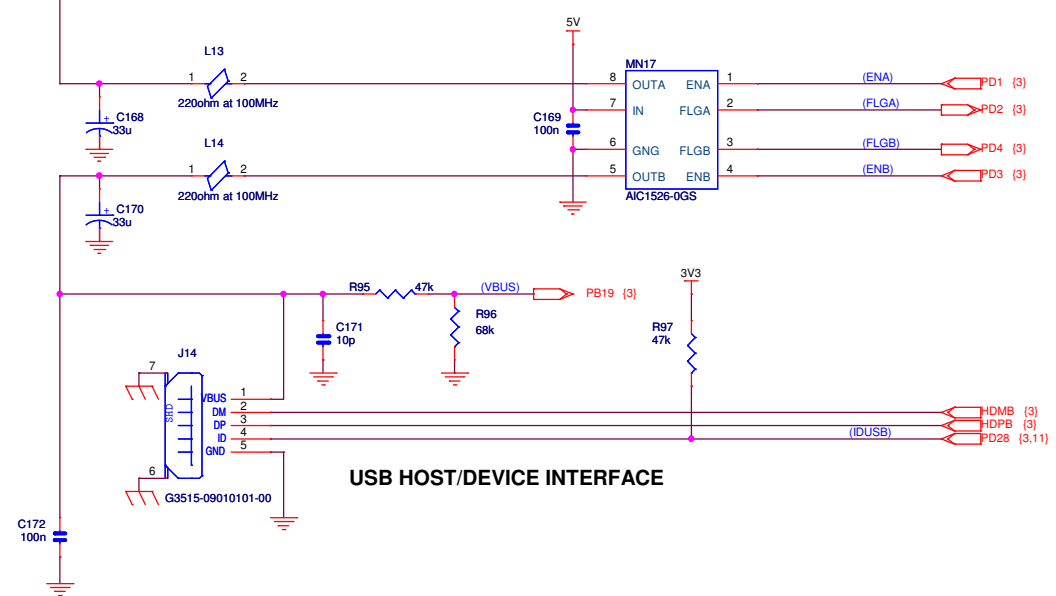

**ICE INTERFACE**

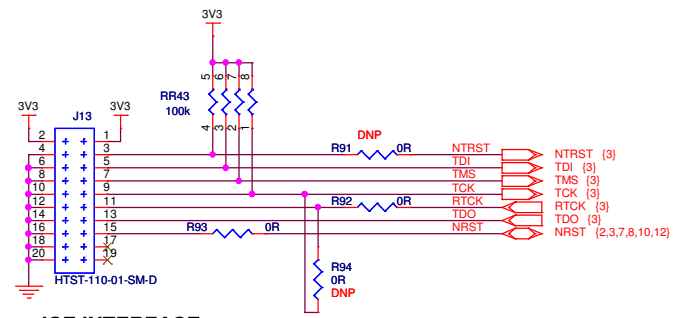

		REV	MODIF.	DES.	DATE	PP	VER.	DATE
		A2		Derek	05-Feb-10	PP		11-FEB-10
<b>AT91SAM9M10-G45-EK</b> SERIAL INTERFACES		SCALE	1/1			REV.	SHEET	
						A2	9/12	

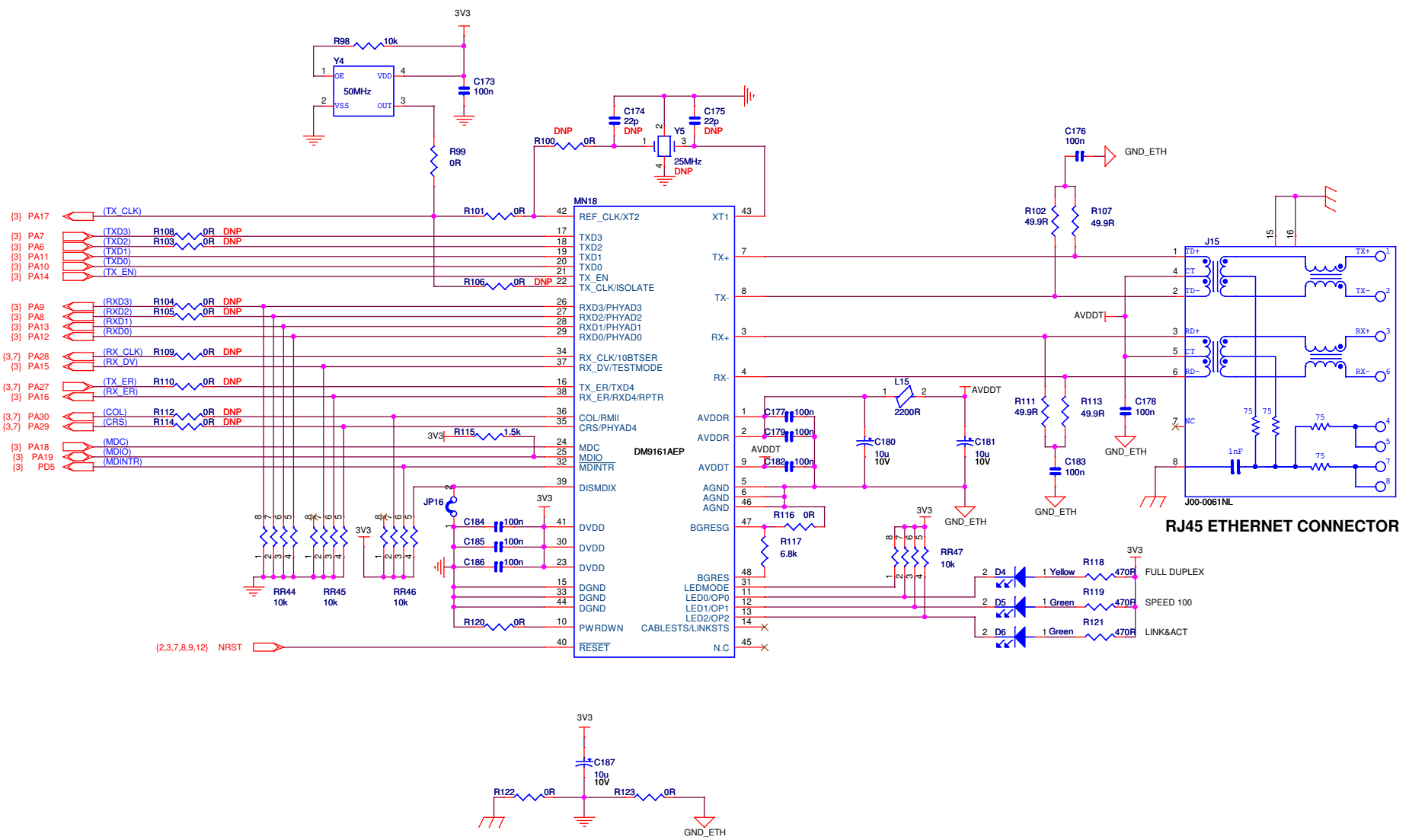

**RJ45 ETHERNET CONNECTOR**

FULL DUPLEX  
SPEED 100  
LINK&ACT

<b>ATMEL</b> ROUSSET					
A2	PP	08-apr-10	PP	11-FEB-10	
REV	MODIF.	Derek	DES.	DATE	05-Feb-10
SCALE 1/1				REV. A2	SHEET 10/12
AT91SAM9M10-G45-EK RMIL_MII ETHERNET					
This agreement is our property. Reproduction and publication without our written authorization shall expose offenders to legal proceedings.					

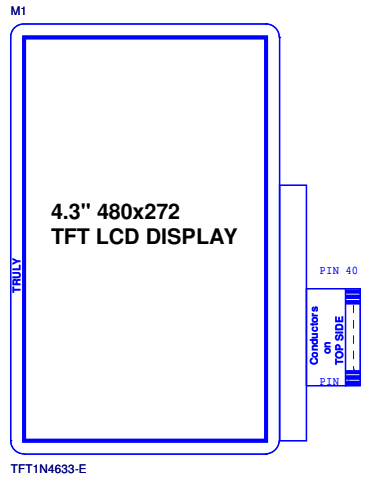

TFT1N4633-E

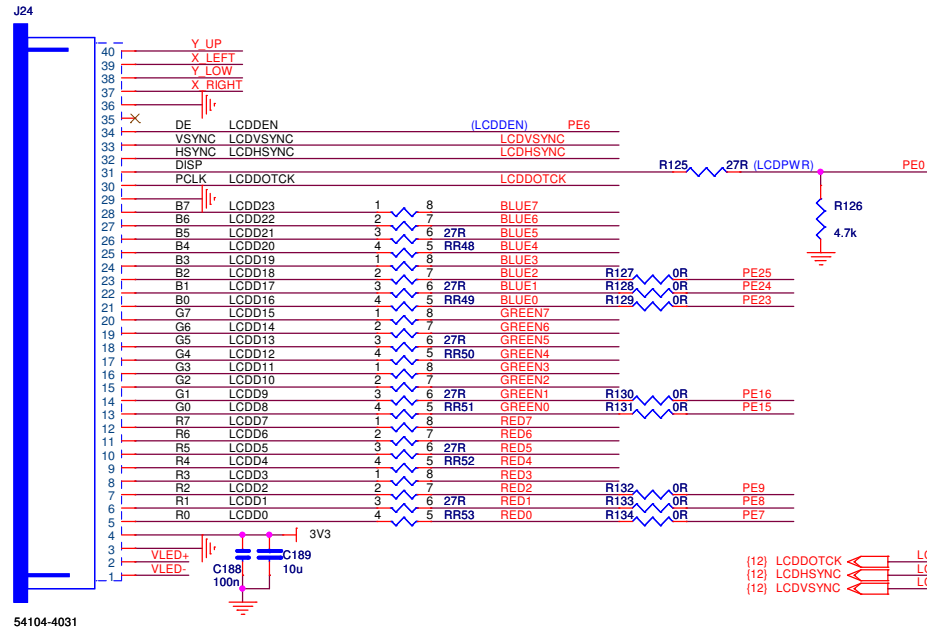

54104-4031

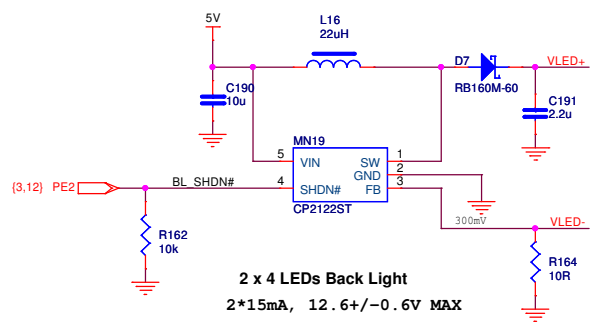
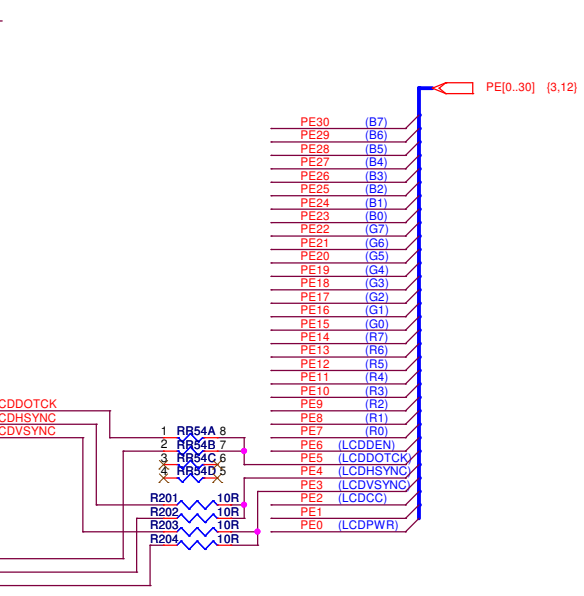

**2 x 4 LEDs Back Light**  
**2\*15mA, 12.6+/-0.6V MAX**

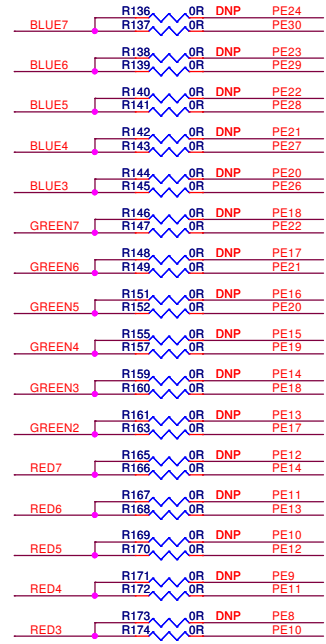
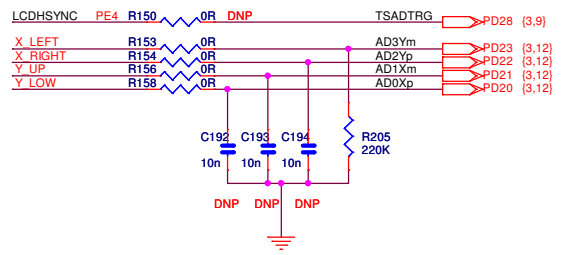

A2		PP	08-apr-10	PP	11-FEB-10
A		Derek	05-Feb-10	VER.	DATE
SCALE	1/1	REV.	11/12		

AT91SAM9M10-G45-EK  
 DISPLAY



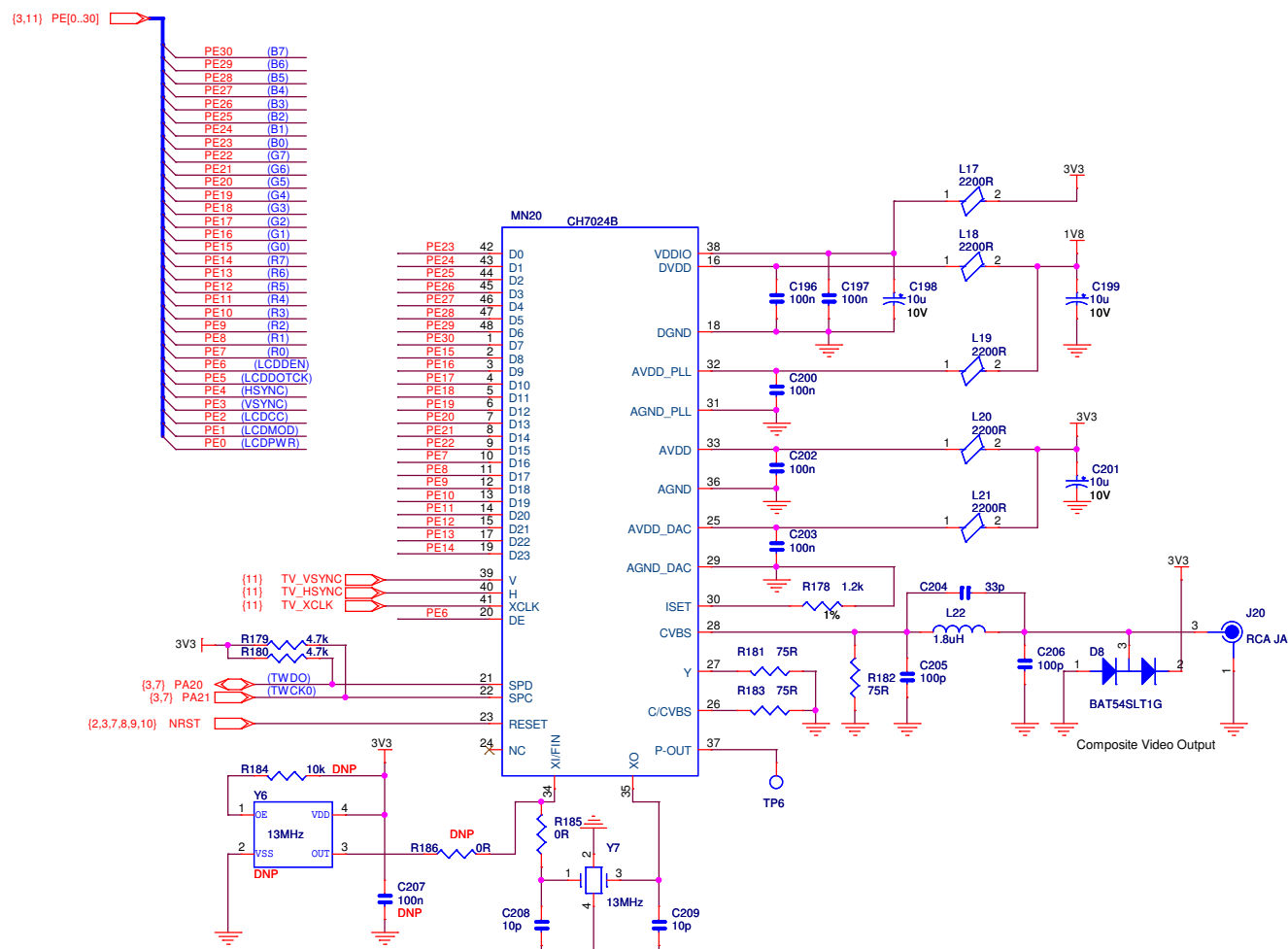

### CONNECTOR EXTENSION FOR LARGE LCD

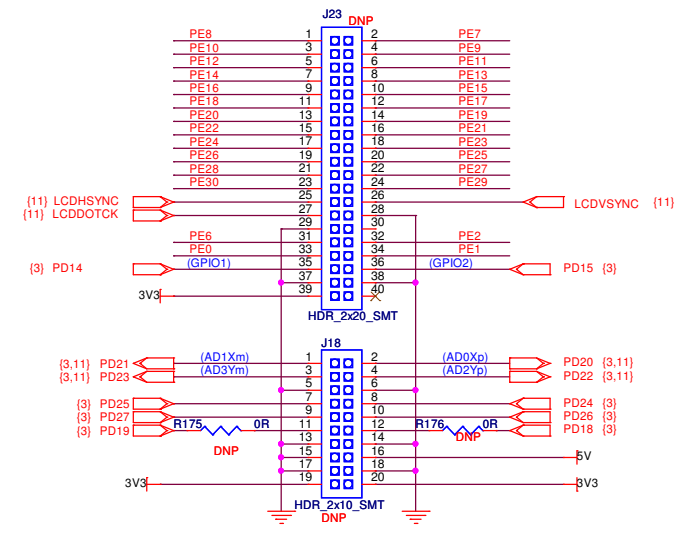

### IMAGE SENSOR CONNECTOR

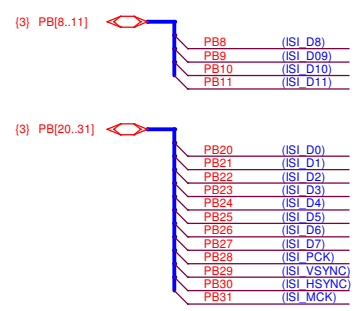
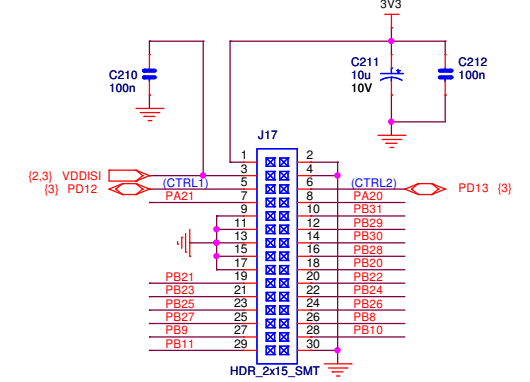

<b>ATMEL</b>					
ROUSSET					
A2	PP	08-apr-10	PP	11-FEB-10	
REV. A	MODIF. Derek	DES. 05-Feb-10	DATE	REV. PP	DATE
AT91SAM9M10-G45-EK		SCALE 1/1		REV. SHEET	
LCD & ISI & VIDEO INTERFACE				A2 12/12	
This agreement is our property. Reproduction and publication without our written authorization shall expose offender to legal proceedings.					



## Section 8

# Revision History

### 8.1 Revision History

Table 8-1.

Document	Comments	Change Request Ref.
6495B	Main edits: - Most Figures updated - Hyperlinks to PDFs updated - 'Serial Synchronous Controller (SSC)' removed - 'JTAG' added - 'RJ45 crossed cable' added - Dimensions updated - Most configuration tables (with LEDs, pins and connectors) updated - 'LG/Philips' reference removed	6990
	New <a href="#">Figure 4-4</a> , "EBI1 - DDR2 + Flash" and new Schematics in <a href="#">Section 7.1</a> "Schematics"	7169
6495A	First issue.	



## Headquarters

---

**Atmel Corporation**  
2325 Orchard Parkway  
San Jose, CA 95131  
USA  
Tel: 1(408) 441-0311  
Fax: 1(408) 487-2600

## International

---

**Atmel Asia**  
Unit 1-5 & 16, 19/F  
BEA Tower, Millennium City 5  
418 Kwun Tong Road  
Kwun Tong, Kowloon  
Hong Kong  
Tel: (852) 2245-6100  
Fax: (852) 2722-1369

**Atmel Europe**  
Le Krebs  
8, Rue Jean-Pierre Timbaud  
BP 309  
78054 Saint-Quentin-en-  
Yvelines Cedex  
France  
Tel: (33) 1-30-60-70-00  
Fax: (33) 1-30-60-71-11

**Atmel Japan**  
9F, Tonetsu Shinkawa Bldg.  
1-24-8 Shinkawa  
Chuo-ku, Tokyo 104-0033  
Japan  
Tel: (81) 3-3523-3551  
Fax: (81) 3-3523-7581

## Product Contact

---

**Web Site**  
[www.atmel.com](http://www.atmel.com)

**Technical Support**  
[AT91SAM Support](#)  
[Atmel technical support](#)

**Sales Contact**  
[www.atmel.com/contacts](http://www.atmel.com/contacts)

**Literature Requests**  
[www.atmel.com/literature](http://www.atmel.com/literature)

---

**Disclaimer:** The information in this document is provided in connection with Atmel products. No license, express or implied, by estoppel or otherwise, to any intellectual property right is granted by this document or in connection with the sale of Atmel products. **EXCEPT AS SET FORTH IN ATMEL'S TERMS AND CONDITIONS OF SALE LOCATED ON ATMEL'S WEB SITE, ATMEL ASSUMES NO LIABILITY WHATSOEVER AND DISCLAIMS ANY EXPRESS, IMPLIED OR STATUTORY WARRANTY RELATING TO ITS PRODUCTS INCLUDING, BUT NOT LIMITED TO, THE IMPLIED WARRANTY OF MERCHANTABILITY, FITNESS FOR A PARTICULAR PURPOSE, OR NON-INFRINGEMENT. IN NO EVENT SHALL ATMEL BE LIABLE FOR ANY DIRECT, INDIRECT, CONSEQUENTIAL, PUNITIVE, SPECIAL OR INCIDENTAL DAMAGES (INCLUDING, WITHOUT LIMITATION, DAMAGES FOR LOSS OF PROFITS, BUSINESS INTERRUPTION, OR LOSS OF INFORMATION) ARISING OUT OF THE USE OR INABILITY TO USE THIS DOCUMENT, EVEN IF ATMEL HAS BEEN ADVISED OF THE POSSIBILITY OF SUCH DAMAGES.** Atmel makes no representations or warranties with respect to the accuracy or completeness of the contents of this document and reserves the right to make changes to specifications and product descriptions at any time without notice. Atmel does not make any commitment to update the information contained herein. Unless specifically provided otherwise, Atmel products are not suitable for, and shall not be used in, automotive applications. Atmel's products are not intended, authorized, or warranted for use as components in applications intended to support or sustain life.

© 2010 Atmel Corporation. All rights reserved. Atmel®, Atmel logo and combinations thereof, DataFlash®, and others are registered trademarks, SAM-ICE™ and others are trademarks of Atmel Corporation or its subsidiaries. Other terms and product names may be trademarks of others.