

THIS DRAWING IS UNPUBLISHED. RELEASED FOR PUBLICATION
 © COPYRIGHT - By - ALL RIGHTS RESERVED.

REVISIONS				
P	LTR	DESCRIPTION	DATE	APVD
B		REV PER ECO 16-002383	3-28-16	CT DE

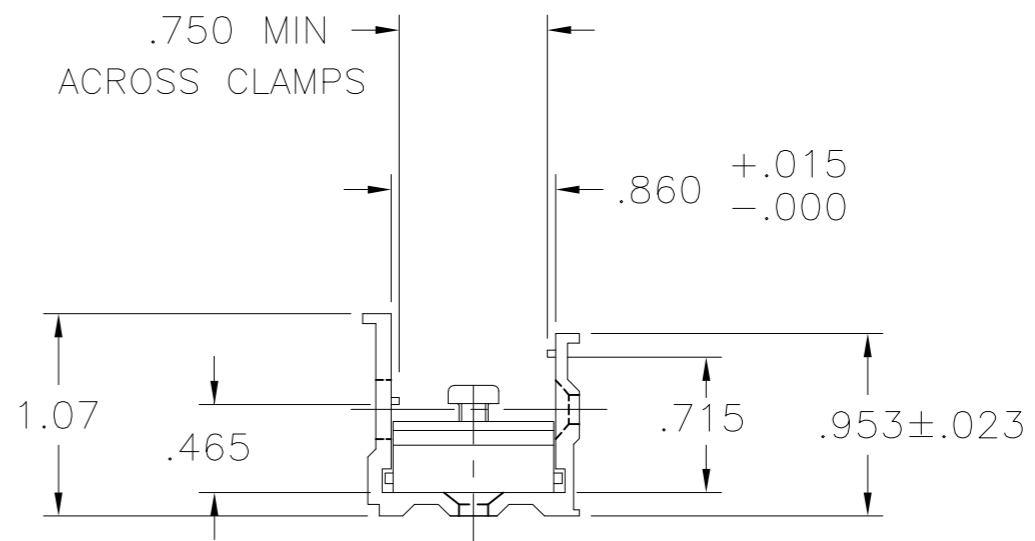
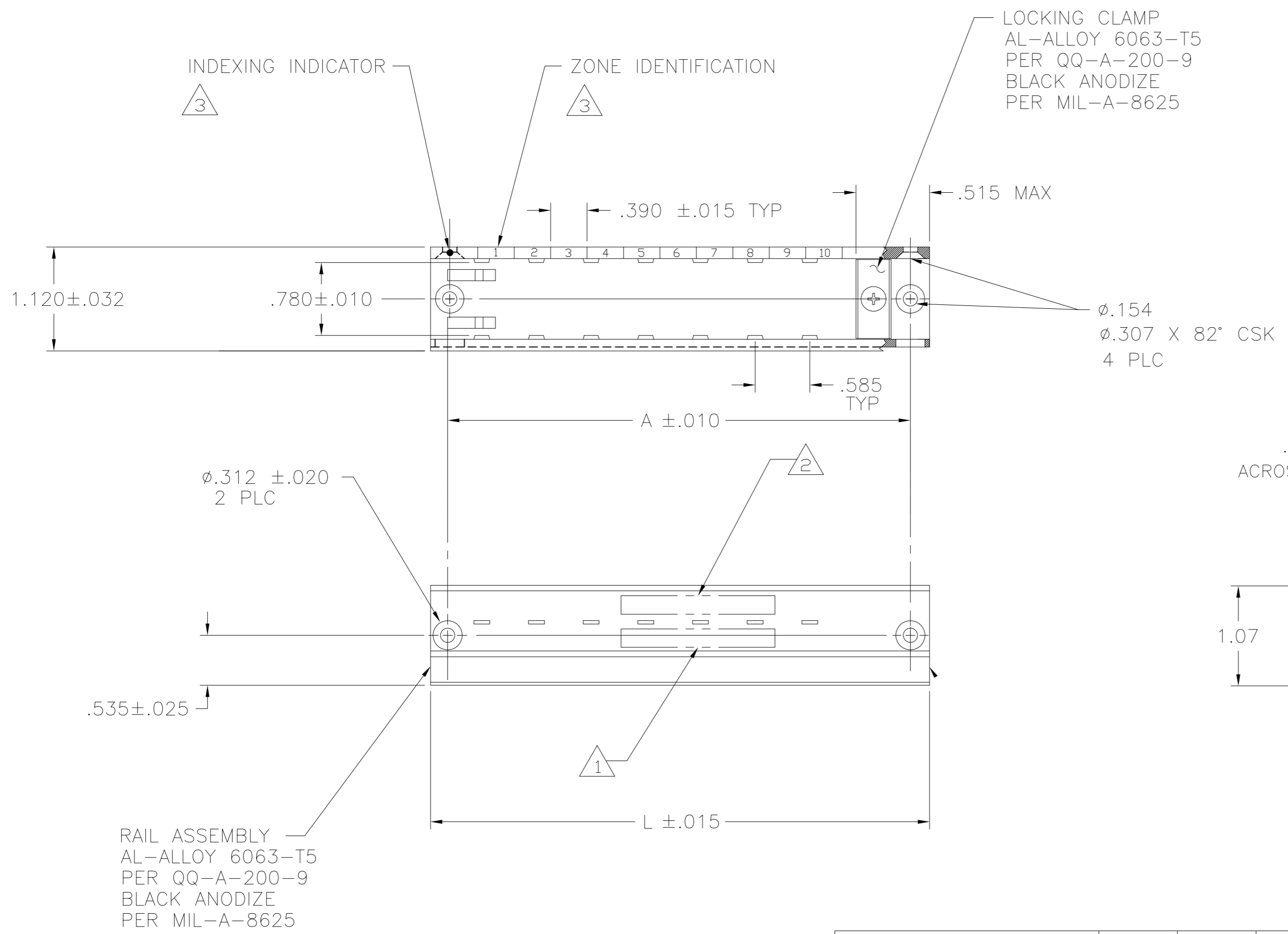

4. PART NO.'S 591613-1 THRU 2-591613-0 WERE FORMERLY MATRIX SCIENCE PART NO.'S MRTB-1 THRU MRTB-20.
- 3 MARK RAIL ASSEMBLY WITH INDEXING INDICATOR AND ZONE IDENTIFICATION AT APPROXIMATE AREA SHOWN.
- 2 MARK RAIL ASSEMBLY WITH CUSTOMER PART NO. .060 MINIMUM HIGH CHARACTERS AT APPROXIMATE AREA SHOWN.
- 1 MARK RAIL ASSEMBLY WITH "AMP", PART NO. AND DATE CODE .060 MINIMUM HIGH CHARACTERS AT APPROXIMATE AREA SHOWN.

MRTB-2	1.671	2.171	2-591613-1
---	8.691	9.191	2-591613-0
---	8.301	8.801	1-591613-9
---	7.911	8.411	1-591613-8
---	7.521	8.021	1-591613-7
---	7.131	7.631	1-591613-6
M81714/5-13	6.741	7.241	1-591613-5
M81714/5-12	6.351	6.815	1-591613-4
M81714/5-11	5.961	6.461	1-591613-3
M81714/5-10	5.571	6.071	1-591613-2
M81714/5-9	5.181	5.681	1-591613-1
CUSTOMER PART NO. 2	DIM. A	DIM. L	PART NO

M81714/5-1	4.791	5.291	1-591613-0
M81714/5-8	4.401	4.901	591613-9
M81714/5-7	4.011	4.511	591613-8
M81714/5-6	3.621	4.121	591613-7
M81714/5-5	3.231	3.731	591613-6
M81714/5-4	2.841	3.341	591613-5
M81714/5-3	2.451	2.951	591613-4
M81714/5-2	2.061	2.561	591613-3
---	1.671	2.171	591613-2
---	1.281	1.781	591613-1
CUSTOMER PART NO. 2	DIM. A	DIM. L	PART NO

THIS DRAWING IS A CONTROLLED DOCUMENT.

DWN	N. FRITZ	4-26-93
CHK	R. RYAN	3-31-93
APVD	R. RYAN	3-31-93
PRODUCT SPEC		
APPLICATION SPEC		
WEIGHT	0	
CUSTOMER DRAWING		

TE Connectivity

RAIL, FEED-BACK ASSEMBLY, TJ

SCALE: NTS SHEET 1 OF 1 REV B

591613