

1

2

3

4

5

6

7

A

A

B

B

C

C

D

D

E

E

F

F

G

G

H

H

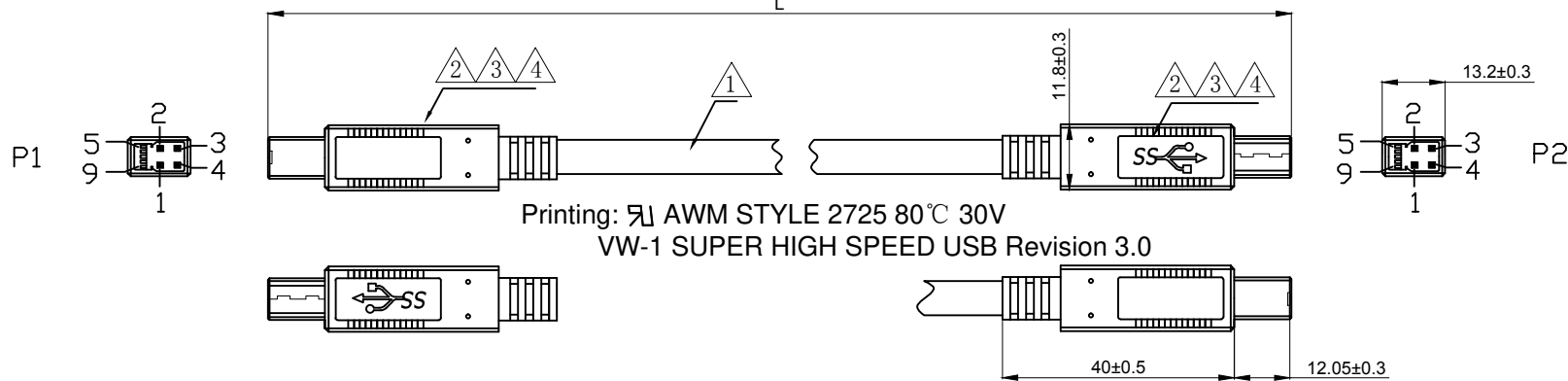

Printing: AWM STYLE 2725 80°C 30V
 VW-1 SUPER HIGH SPEED USB Revision 3.0

① Pin Assignment

P1		P2
1	Red	1
2	White	2
3	Green	3
4	Black	4
5	Blue	5
6	Yellow	6
7	Drain	7
8	Orange	8
9	Purple	9
Shell	Braid	Shell

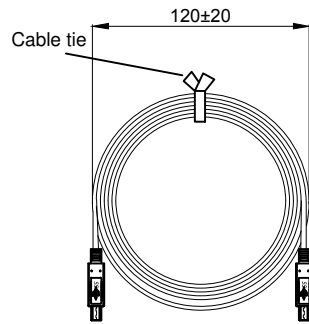

NOTES:

1. Cable Must Be Open, Short, Miswire 100% Test
2. Voltage: 300V DC
3. Contact Resistance: 5ohms max.
4. Insulation Resistance: 10M ohms min.
5. 1Pcs/PE Bag

② WSW P/N	Length(mm)	Qty/Per Carton
A-USB30BM-30BM-050	500±20	200
A-USB30BM-30BM-100	1000±30	150
A-USB30BM-30BM-200	2000±50	100
A-USB30BM-30BM-300	3000±50	70
A-USB30BM-30BM-500	5000±50	50

②	NO.	TITLE	DESCRIPTION
④	Inner Mold	LDPE WHITE	
③	Over Mold	PVC 45P Black	
②	CONN	USB3.0 B/M, Blue, PIN G/F, Shell Ni-Plated	
①	CABLE	UL2725(Rev 3.0), OD:5.5mm BLACK, (1P#30+D+AL+Mylar)*2C+1P#30+2C#24+AL+B	

RoHS compliant
 Unit: mm

Scale	FREE					Date	Name	Customer-No.
TOLERANCE					Drawn	07.01.2019	Xavier	
					Approved	11.12.2019	Winnie	ASSMANN WSW-No. A-USB30BM-30BM-xxx
DIM	TOL	②	Packing quantities & PVC hardness	10.12.2019	Winnie			Drawing-No. ASS 8455 CA rev02
		①	Add wire color	07.15.2019	Xavier			
		①	Drawn	07.01.2019	Xavier			
Angle	TOL	Id.	Modification	Date	Name			Replace
								Sheet

1

2

3

4

5

6

7