

APPROVAL SHEET



WLCW3225
SMD Wire Wound Ceramic Chip Inductors

*Contents in this sheet are subject to change without prior notice.

Features

1. Standard chip size bobbin with wire wound coil provides high reliability, productivity and performance.
2. Excellence Q and SRF characteristics for RF application, such as LO tank, antenna matching and filter.
3. Wide range inductance and various tolerance options.
4. RoHS compliant.

Applications

1. Communication: GSM/3G/LTE, Wi-Fi, GPS.
2. Consumer: Cabel/Terrestrial/BS Tuner, Bluetooth, Wireless Audio, Remote control.
3. M2M: ZigBee, Proprietary wireless.

Shape and Dimension

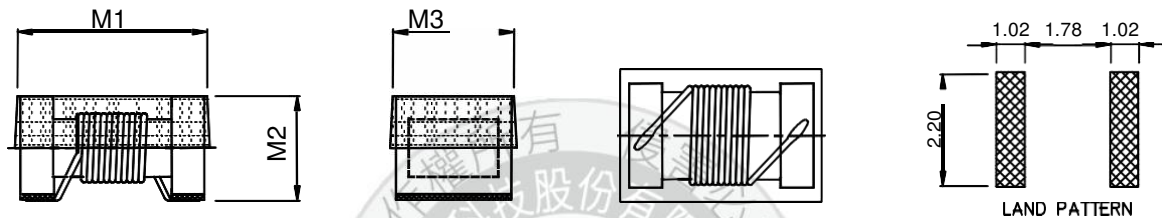

Unit:mm

Unit: mm

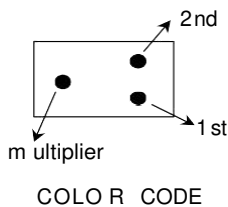

Example : WLCW3225Z0□4N7PB

MARKING : Dots 1 and 2 indicate the inductance in nano Henries.
(DOTS 1 : YELLOW, DOTS 2 : VIOLET)
Dots 3 indicates number of zeroes to be added.
(DOTS 3 : BLACK)

WLCW Series	M1	M2	M3
3225	3.42(MAX)	2.30(MAX)	2.80(MAX)

Ordering Information

WL	CW	3225	Z0	J	4N7	P	B
Product Code	Series	Dimensions	Series extension	Tolerance	Value	Packing Code	
WL: Inductor	SMD Wire Wound Ceramic Chip inductor.	3225 :EIA 1210	Z0:STD	G: ± 2% J: ± 5% K: ±10%	4N7 =4.7nH R12 =120nH 2R2 =2200nH 12N =12nH	P=7" Reeled (Embossed tape)	B:STD

Electrical Characteristics

WLCW3225 series

Walsin Part Number	L (nH)	Tolerance	Measuring Frequency (MHz)	Q (Min)	Test Freq (MHz)	SRF (MHz) Min	DCR Max (Ω)	I _{rms} (mA)	Color Code		
									1st	2nd	multiplier
WLCW3225Z0□4N7PB	4.7	K, J	100	50	1000	6000	0.06	600	Yellow	Violet	Black
WLCW3225Z0□5N6PB	5.6	K, J	100	50	1000	5500	0.08	600	Green	Blue	Black
WLCW3225Z0□10NPB	10	K, J, G	100	60	500	4000	0.06	600	Brown	Black	Brown
WLCW3225Z0□12NPB	12	K, J, G	100	60	500	3400	0.06	600	Brown	Red	Brown
WLCW3225Z0□15NPB	15	K, J, G	100	60	500	3200	0.06	600	Brown	Green	Brown
WLCW3225Z0□18NPB	18	K, J, G	100	60	300	2800	0.06	600	Brown	Gray	Brown
WLCW3225Z0□22NPB	22	K, J, G	100	60	300	2300	0.08	600	Red	Red	Brown
WLCW3225Z0□27NPB	27	K, J, G	100	60	300	2000	0.08	600	Red	Violet	Brown
WLCW3225Z0□33NPB	33	K, J, G	100	60	300	1800	0.08	600	Orange	Orange	Brown
WLCW3225Z0□39NPB	39	K, J, G	100	60	300	1800	0.08	600	Orange	White	Brown
WLCW3225Z0□47NPB	47	K, J, G	100	60	300	1600	0.08	600	Yellow	Violet	Brown
WLCW3225Z0□56NPB	56	K, J, G	100	60	300	1500	0.10	600	Green	Blue	Brown
WLCW3225Z0□68NPB	68	K, J, G	100	60	300	1300	0.10	600	Blue	Gray	Brown
WLCW3225Z0□82NPB	82	K, J, G	100	60	300	1200	0.10	600	Gray	Red	Brown
WLCW3225Z0□91NPB	91	K, J, G	100	60	300	1100	0.10	1000	White	Brown	Brown
WLCW3225Z0□R10PB	100	K, J, G	100	60	300	1100	0.10	1000	Brown	Black	Red
WLCW3225Z0□R12PB	120	K, J, G	50	60	300	900	0.12	500	Brown	Red	Red
WLCW3225Z0□R15PB	150	K, J, G	50	60	300	800	0.18	500	Brown	Green	Red
WLCW3225Z0□R18PB	180	K, J, G	50	60	300	760	0.21	500	Brown	Gray	Red
WLCW3225Z0□R22PB	220	K, J, G	50	60	300	760	0.27	500	Red	Red	Red
WLCW3225Z0□R27PB	270	K, J, G	50	50	300	660	0.33	500	Red	Violet	Red
WLCW3225Z0□R33PB	330	K, J, G	50	50	100	650	0.37	500	Orange	Orange	Red
WLCW3225Z0□R36PB	360	K, J, G	50	50	100	500	0.63	600	Orange	Blue	Red
WLCW3225Z0□R39PB	390	K, J, G	50	50	100	600	0.63	500	Orange	White	Red
WLCW3225Z0□R47PB	470	K, J, G	50	50	100	550	0.69	400	Yellow	Violet	Red
WLCW3225Z0□R56PB	560	K, J, G	50	50	100	470	0.90	400	Green	Blue	Red
WLCW3225Z0□R68PB	680	K, J, G	25	50	100	450	1.05	400	Blue	Gray	Red
WLCW3225Z0□R82PB	820	K, J, G	25	50	100	400	1.45	350	Gray	Red	Red
WLCW3225Z0□R91PB	910	K, J, G	25	50	100	400	1.45	350	White	Brown	Red
WLCW3225Z0□1R0PB	1000	K, J, G	25	45	100	340	2.10	280	Brown	Black	Orange
WLCW3225Z0□1R2PB	1200	K, J, G	7.96	45	50	320	2.40	250	Brown	Red	Orange
WLCW3225Z0□1R5PB	1500	K, J, G	7.96	45	50	300	2.70	220	Brown	Green	Orange
WLCW3225Z0□1R8PB	1800	K, J, G	7.96	45	50	280	3.50	180	Brown	Gray	Orange
WLCW3225Z0□2R2PB	2200	K, J, G	7.96	45	50	260	3.80	150	Red	Red	Orange
WLCW3225Z0□3R3PB	3300	K, J, G	27	25	27	140	10	150	Orange	Orange	Orange

Tolerance: K: $\pm 10\%$ 、J: $\pm 5\%$ 、G: $\pm 2\%$
 OPERATING TEMPERATURE : $-40^{\circ}\text{C} \sim 125^{\circ}\text{C}$
 ※MSL: LEVEL 1
 L、Q TEST BY HP4291B
 SRF TEST BY HP 8753E
 DCR TEST BY ZENTECH 502BC

RELIABILITY PERFORMANCE

Reliability Experiment For Electrical

Test Item	Test Condition	Standard Source
Humidity Test	+40°C± 2°C, humidity of 90% ± 5% (total 96 hours).	MIL-STD-202G Method 103B Test Condition B
High Temperature Test	1.Temperature: +125°C±2°C 2.Test time: 48±2hrs	IEC 68-2 Test Condition B
Low Temperature Test	1.Temperature: -40°C±2°C 2.Test time: 48±2hrs	IEC 68-2 Test Condition A
Thermal Shock	+125°C±5°C (30 minutes) ~ -40 ± 5°C (30 minutes), temperature switch time: 5 minutes (total 50 cycles).	MIL-STD-202G Method 107G Test Condition B-2
Life Test	+70°C±5°C (250Hours)	MIL-STD-202G Method 108A Test Condition B

Reliability Experiment For Physical

Test Item	Test Condition	Standard Source
Vibration Test	10-55-10HZ, amplitude: 1.5mm, direction: X, Y, Z axes, each axis 2 hours (total 6 hours).	MIL-STD-202G Method 201A
Solder Heat Resistance Test	IR/convection reflow:Peak Temp 250±5°C for 5Sec in air, Through 2 Cycle. Temperature Ramp:+1~4°C/sec; Above 183°C, must keep 90 s - 120 s	MIL-STD-202G Method 210F Test Condition (Reflow)
Solder Ability Test	Soak in 245 °C solder pot of 3Sec, PAD must have 95% above coverage.	J-STD-003B

Typical RoHS Reflow Profile

Typical RoHS Reflow Profile

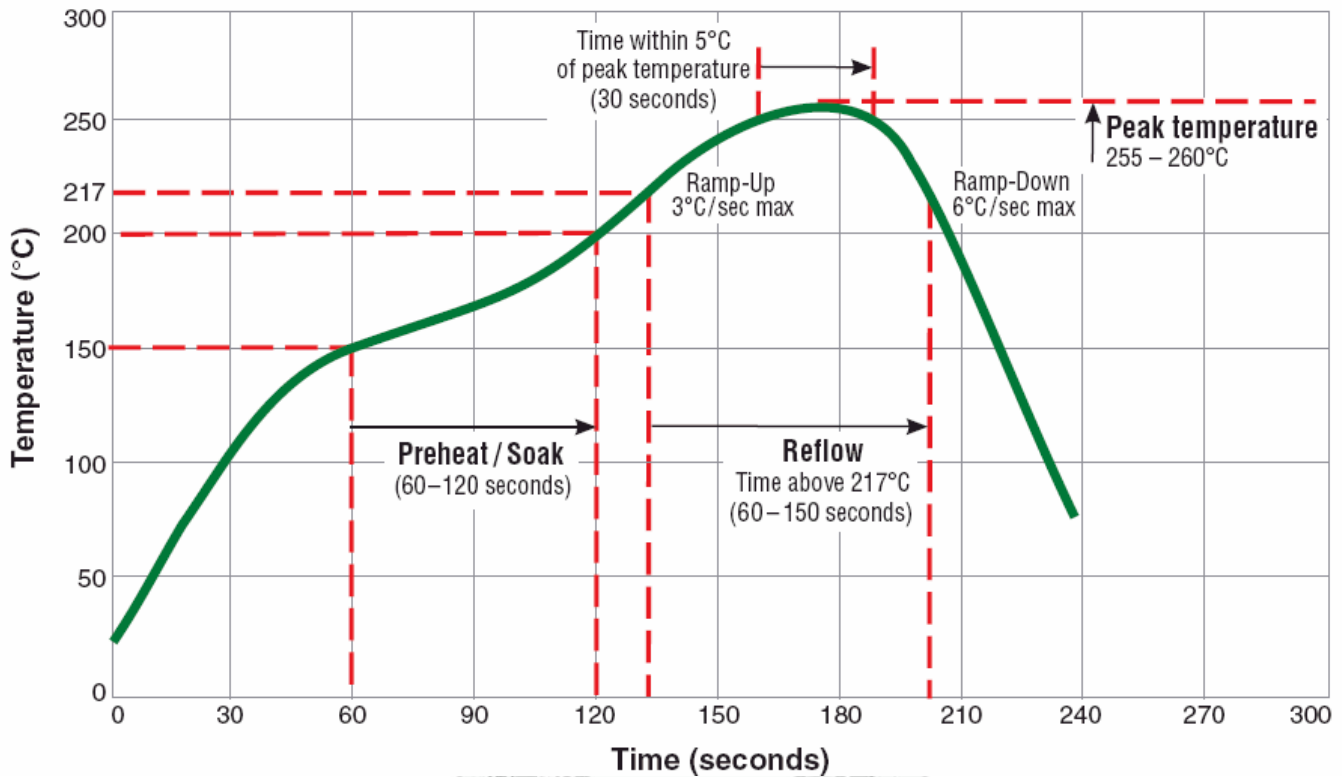

Packaging Specification

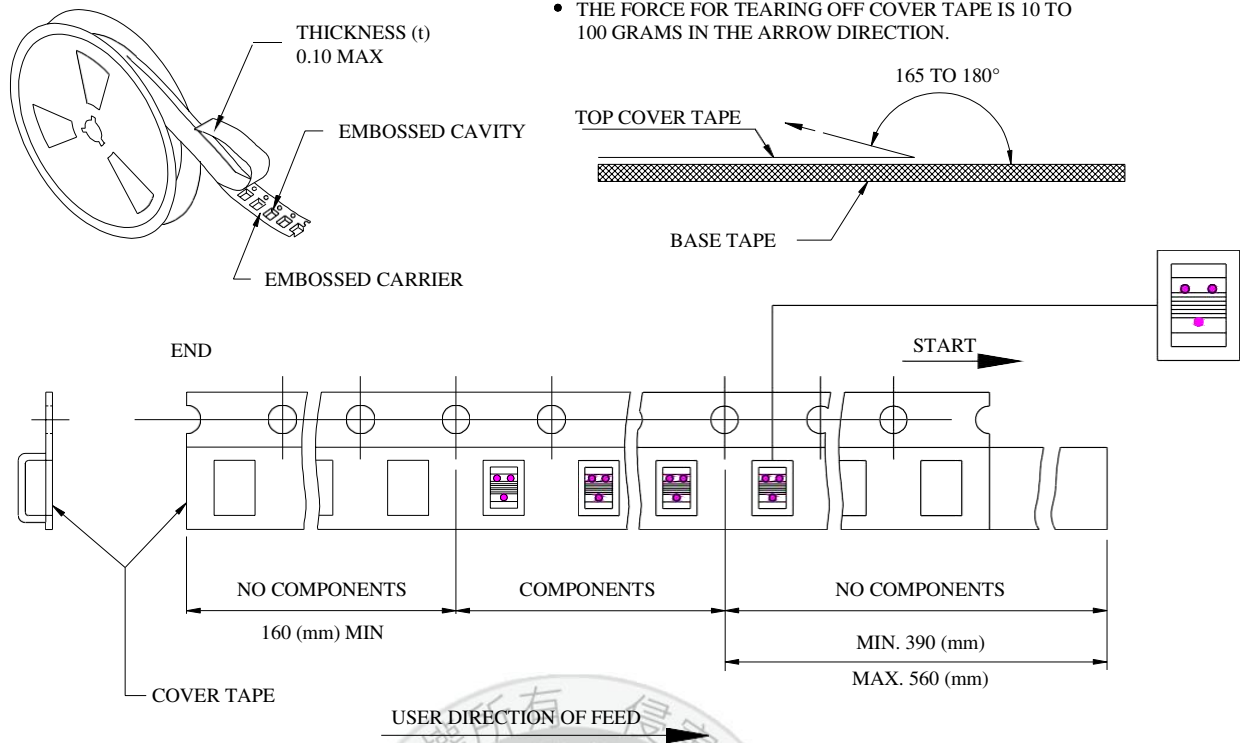

■ CARRIER TAPE REELS (mm)

MATERIAL: PLASTIC

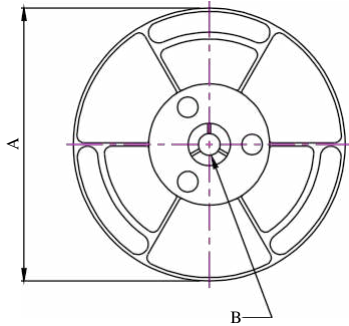

■ DIMENSIONS OF CARRIER TAPE (mm)

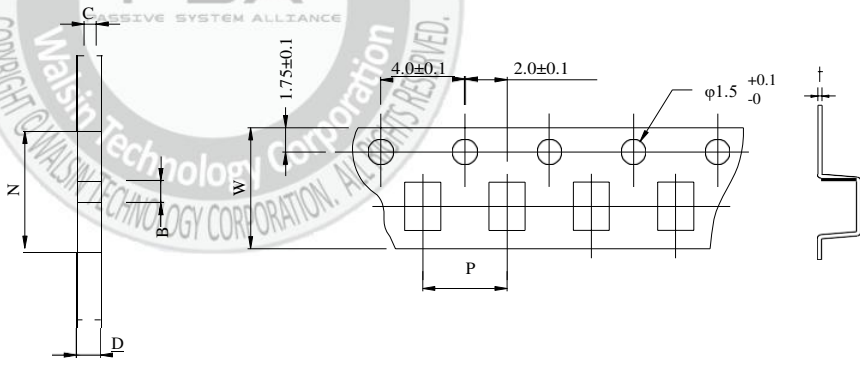

	A	B	C	D	N	P	W	t
DIM.	178	13.0	8.4	12.5	50	4.0	8.0	0.25
TOL.	±2.0	±0.8	+1.0-0	MAX	MIN	±0.1	±0.2	±0.05

Quantity per reel : 1.5K pcs