

APPLICATION

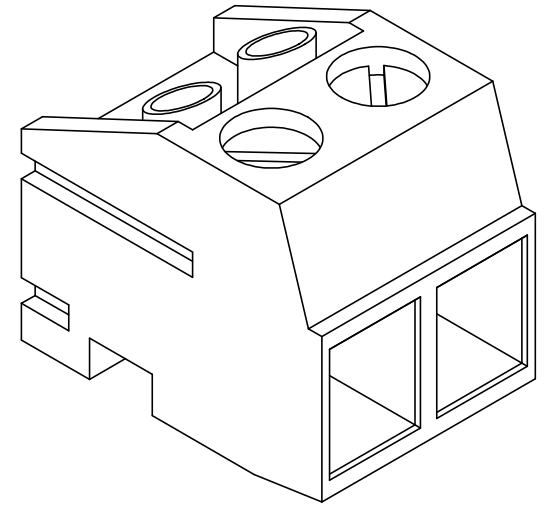
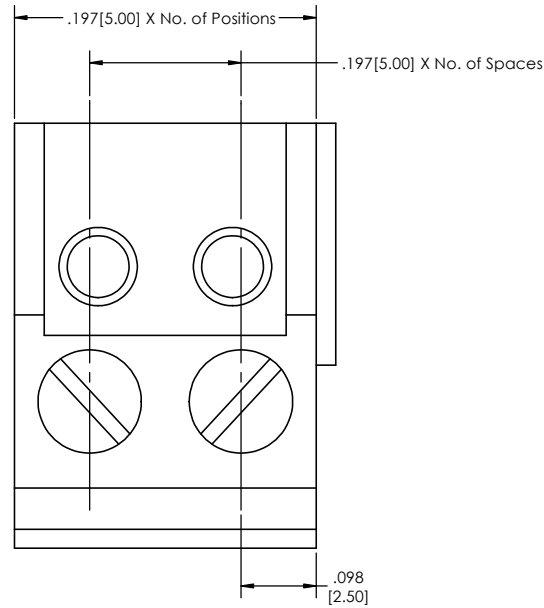
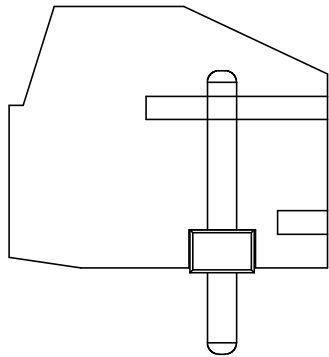

TBW - 11 - **197** - **XX** - **XX** - **LF**
(A) (B) (C) (D)

- A. Pitch**
 - 197= .197(5.00) cl
- B. No. of Positions**
 - 02-24
- C. Color**
 - GR= Green (Standard)
 - BK= Black
 - BL= Blue
 - WH= White
 - GY= Grey
 - OR= Orange
 - YW= Yellow
 - RD= Red
 - BR= Brown
- D. Lead Free**

Mates With:
 TBWH-11-197-XX-XX-LF

Specifications:
 Current Rating: 10 Ampere
 Voltage Rating: AC 250V
 Wire Range: 14-24 AWG
 Insulation Resistance: DC 500V 500M ohms
 Dielectric Withstanding Voltage: AC 2500V/1 minute
 Operation Temperature: -33°C to +105°C
 Strip Length: .197-.236 (5-6mm)
 Max. Torque: 3.04 lb-in (3.5kgf. cm)

- Materials:**
- Body: PA66 (Nylon), UL94 V-0
 - Screw: M2.5*P0.45, C1018 Steel, Zinc Plated
 - Terminal: Brass, Nickel Plated
 - Contact: Phosphor Bronze, Tin Plated

Tails may be clipped to achieve specific dimensions.
 Products cut to specific sizes are uncancellable/ nonreturnable.
 Parts are subject to change without notice.

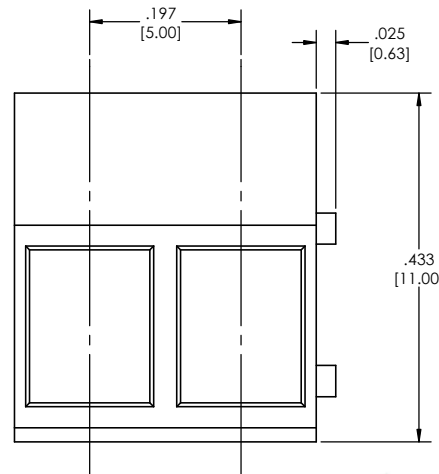
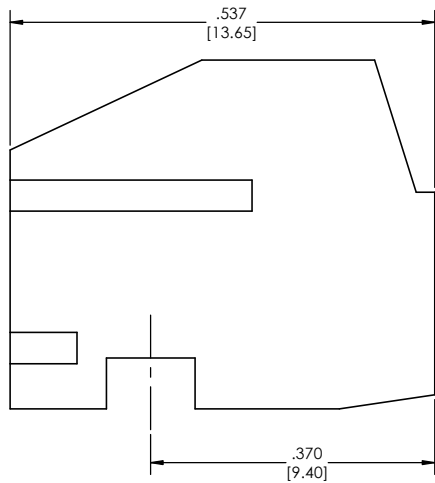

PROPRIETARY AND CONFIDENTIAL
 THE INFORMATION CONTAINED IN THIS DRAWING IS THE SOLE PROPERTY OF Major League Electronics. ANY REPRODUCTION IN PART OR AS A WHOLE WITHOUT THE WRITTEN PERMISSION OF Major League Electronics IS PROHIBITED.

UNLESS OTHERWISE SPECIFIED:		NAME		DATE	
DIMENSIONS ARE IN INCHES		DRAWN	EOW	04/16/14	
TOLERANCES:		CHECKED	GWE	04/16/14	
ONE DECIMALS ±.100		ENG APPR.			
TWO DECIMAL ±.100		MFG APPR.			TITLE: TBW-11-197 Series SIZE DWG. NO. C REV A SCALE 8:1 SHEET 1 OF 1
THREE DECIMAL ±.005		ADDRESS:		2533 Centennial Blvd.	
FOUR DECIMAL ±.002		MATERIAL:		Jeffersonville, In 47130	
NEXT ASSY USED ON		FINISH:		Phone: 812-670-4174	
APPLICATION		DO NOT SCALE DRAWING		E-Mail: mle@mlelectronics.com	